

# Digital Motion Picture Camera

## VENICE 2

Operating Instructions

MPC-3628/MPC-3626

Firmware Version 1.0



# Table of Contents

## 1. Overview

Features .....	3
System Configuration.....	8
Location and Function of Parts.....	9

## 2. Preparation

Preparing a Power Supply .....	17
Setting the Clock .....	18
Interchanging the Imager Block.....	19
Attaching the VF Attachment and Handle .....	20
Mounting a Lens and Adjusting the Flange Focal Length .....	21
Attaching a Viewfinder .....	24
Handling AXS Memory Cards .....	26
Handling SD Cards for Saving Configuration Data.....	34

## 3. Camera Operations

Sub Display .....	35
Operations on the Home Screen of the Sub Display .....	38
User Functions Screen .....	48
Menu Operations .....	54
Full Menu Operations.....	64
Shooting Menu .....	65
Project Menu .....	72
TC/Media Menu .....	76
Monitoring Menu .....	77
Audio Menu .....	84
Paint Menu .....	85
Technical Menu .....	87
Maintenance Menu .....	92

Clip Operations on the Sub Display .....	93
Playback.....	95
Operations on the Home Screen of the Mini Display .....	96
Clip Operations on the Mini Display.....	99

## 4. Network

Network Setup and Operations .....	100
------------------------------------	-----

## 5. Shooting

Basic Operation.....	107
Useful Functions .....	108

## 6. Saving and Loading User Configuration Data

User Configuration Data.....	111
All Files.....	112
Scene Files .....	113
User Gamma Files .....	114

## 7. Connecting External Devices

Connecting a Remote Control Unit.....	115
Connecting External Monitors and Recording Devices .....	120
External Synchronization .....	121

## 8. Appendix

Usage Precautions .....	122
Recording Formats and Output Signals .....	125
AXS Clip Recording/Playback Time.....	135
Error/Warning Indications.....	137
Items Saved in Files .....	139
Recording and Output Metadata List.....	146

Licenses.....	149
---------------	-----

Specifications .....	150
----------------------	-----

# Features

## New 8.6K 36 mm × 24 mm full frame CMOS image sensor (MPC-3628)

The MPC-3628 is equipped with a newly developed 36 mm × 24 mm full frame, 8.6K CMOS image sensor and can record images up to 8640×5760 pixels.\* By switching the imager mode, the unit supports standard Super 35mm 24.1 mm × 12.7 mm, 5792×3056 pixel resolution and 6:5 anamorphic, Super 35mm 24.1 mm × 20.2 mm, 5792×4854 pixel resolution.\* This makes the unit effective not only for 8K content production but also for VFX compositing. It is also possible to produce high-quality 4K content by oversampling from 8.6K resolution content.

\* Full-Frame and Anamorphic modes require licenses sold separately.

## 6K 36 mm × 24 mm full frame CMOS image sensor (MPC-3626)

The MPC-3626 features the same image sensor as VENICE (MPC-3610) and supports image capture at resolutions up to 6048×4032 pixels.\* By switching the imager mode, the unit supports standard Super 35mm 24.3 mm × 12.8 mm, 4096×2160 pixel resolution (equivalent to 3-perforation motion picture film) and 4:3 anamorphic, Super 35mm 24.3 mm × 18.3 mm, 4096 × 3024 pixel resolution (equivalent to 4-perforation motion picture film).\*

\* Full-Frame and Anamorphic modes require licenses sold separately.

## Two interchangeable image sensors

The 8.6K image sensor and 6K image sensor both feature system compatibility, allowing the user to interchange the image sensor used for operation. The VENICE (MPC-3610) imager block is also compatible and can be attached to the MPC-3628/3626.

## Wide latitude

The MPC-3628 supports 16 stops of latitude, while the MPC-3626 supports 15+ stops of latitude. It features very low noise for delivering phenomenal images in conditions from searing sunlight to almost no light, allowing for unprecedented creative freedom in grading.

## Wide color space capture

Images can be captured in a color space that exceeds DCI-P3. The degree of freedom in the grading is dramatically improved when using Sony's S-Gamut3 and S-Gamut3.Cine color space together with S-Log3.

## Dual Base ISO

Two types of base sensitivity are supported. Using the low Base ISO setting (MPC-3628: ISO 800, MPC-3626: ISO 500) under normal lighting conditions or the high Base ISO setting (MPC-3628: ISO 3200, MPC-3626: ISO 2500) under low light conditions allows you to maintain the latitude balance between highlights and lowlights when shooting, without graining (noise).

## PL lens mount

Equipped with the industry-standard PL lens mount. The lens mount supports Cooke /i technology, and lens information is recorded as metadata frame by frame. Lens distortion and shading metadata are recorded, compatible with Cooke's /i third generation metadata technology (/i<sup>3</sup>) and ZEISS eXtended Data Technology.

## E-mount lens support

E-mount lenses are supported by removing the PL lens adaptor. E-mount lenses are

smaller and lighter than PL lenses, and are available in a diverse lineup for expanded possibilities in image reproduction.

## Imager block extension

On the MPC-3626 equipped with a 6K image sensor, the imager block can be extended from the camera body by 2.7 m (8.9 ft) or 5.5 m (18 ft) by connecting the CBK-3610XS Camera Extension System, which also enables shooting with a more compact camera head.

## 8-position optical ND filter

Employs an 8-position optical ND filter. It offers a wide ND range of 0.3ND (1/2 = 1 stop) to 2.4ND (1/256 = 8 stops) that reduces time lost on set changing external ND filters. The ND filter mechanism is servo-controllable, and can be controlled from a computer, tablet, or RM/RCP controller.

## High Frame Rate (HFR) shooting

The 8.6K image sensor can record X-OCN at frame rates up to 90 FPS, while the 6K image sensor can record X-OCN at up to 120 FPS.

## X-OCN and 4K ProRes recording formats

Video can be recorded in 16-bit X-OCN or 4K ProRes, as standard recording formats, to AXS memory cards. X-OCN is a format that can be handled natively by many NLEs and grading tools, and is recorded at the full resolution of each sensor in each mode. 4K ProRes is widely used as a 4K video format, and the image captured by each image sensor in each mode is oversampled\* and recorded in 4K ProRes.

\* When using the 6K image sensor (MPC-3626) in 4K 17:9, 4K 16:9, or 4K 2.39:1 imager mode, the captured 4K image is recorded as-is.

## Compact body and intuitive operation

A relatively compact design for a device equipped with a large full-frame image sensor, achieved using Sony's miniaturization technology, which allows easier shooting in confined spaces or on drones. The position, shape, and size of the control buttons reflect the requirements of camera operators for intuitive operation. They also feature backlighting for ease of use in dark locations.

## Engineered to survive

The chassis is made from magnesium alloy for high robustness and durability. The ventilation system is completely isolated from all electronic components to prevent ingress of dust, sand, and liquids.\* The silent-running fan can be removed and cleaned on-set quickly and easily to maintain high readiness.

\* Design protects against dust and rain, but cannot completely prevent the ingress of dust and liquid.

## Modular design

The design allows you to flexibly support various rigs and peripheral equipment according to the shooting application. The top handle and viewfinder are easily adjustable to maintain ergonomic balance and ease of use with lenses.

## Intuitive and familiar on-set menu operation

The menu screen is available from both sides of the camera, with the main control display on the Assistant side of the camera for fast access to the camera settings by the camera assistant while shooting. An OLED mini display on the Operator side allows the operator to access commonly accessed features such as ND filter position, shutter, white balance, exposure index (EI), and frame rate (FPS),

making it convenient for the operator to check the status of the unit.

### Paint control from RM/RCP and this unit

The unit supports control from an RM/RCP remote control panel that can be used with broadcast camcorders and system cameras. Adjustment of various paint items is supported. Paint control operations are also supported using the full menu of the unit.

## Effective Picture Size

The unit supports shooting in the following effective picture sizes.

### MPC-3628

**[Note]**

A software license is required to shoot in 8.6K 3:2, 8.2K 17:9, 7.6K 16:9, and 5.8K 6:5.

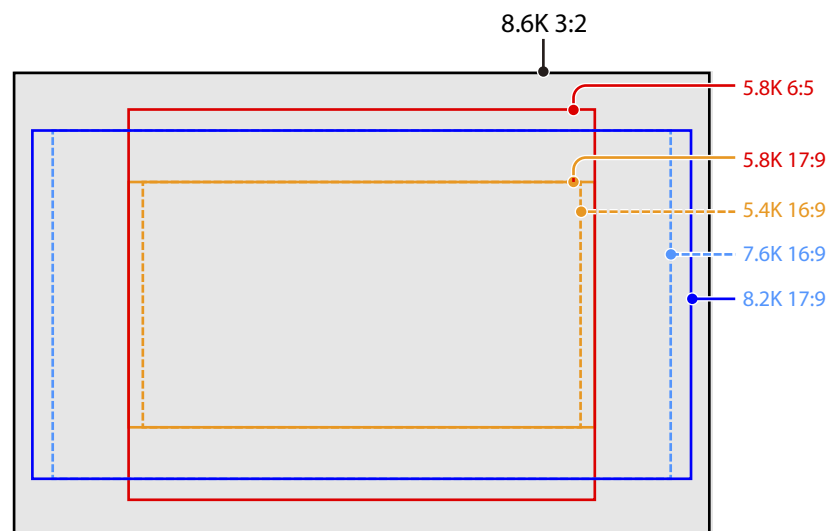

## MPC-3626

### [Note]

A software license is required to shoot in 6K 3:2, 6K 1.85:1, 6K 17:9, 6K 2.39:1, 5.7K 16:9, 4K 6:5, 4K 4:3, and 4K 4:3 Surround View.

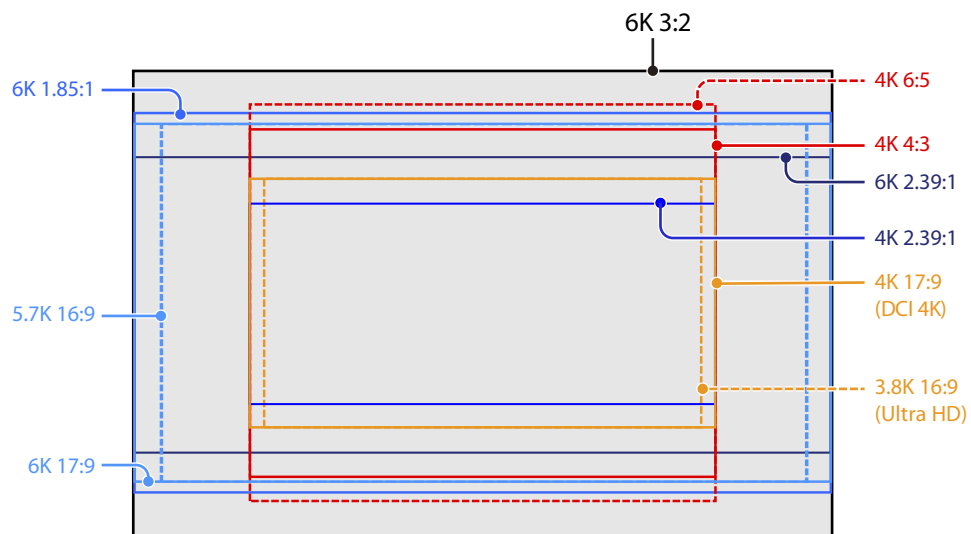

## Software Licenses

You can select software licenses (optional) according to the intended usage of the unit. Software licenses are installed using Maintenance > License Options (page 92) in the full menu.

### MPC-3628

Software license	Imager mode	Effective number of pixels (Image pixels)	W × H (mm)	Project frame rate
FULL-FRAME LICENSE <sup>1)</sup>	8.6K 3:2	8640 × 5760	35.9 × 24.0	23, 24, 25, 29
	8.2K 17:9	8192 × 4320	34.1 × 18.0	23, 24, 25, 29, 47, 50, 59
	7.6K 16:9	7680 × 4320	32.0 × 18.0	23, 24, 25, 29, 50, 59
ANAMORPHIC LICENSE	5.8K 6:5	5792 × 4854	24.1 × 20.2	23, 24, 25, 29, 47
License not required <sup>1)</sup>	5.8K 17:9	5792 × 3056	24.1 × 12.7	23, 24, 25, 29, 47, 50, 59
	5.4K 16:9	5434 × 3056	22.6 × 12.7	23, 24, 25, 29, 50, 59

<sup>1)</sup> The Anamorphic License is required to enable ratio settings, other than Off(1.0×), for the de-squeeze function.

## MPC-3626

Software license	Imager mode	Effective number of pixels (Image pixels)	W × H (mm)	Project frame rate
FULL-FRAME LICENSE <sup>1)</sup>	6K 3:2	6048 × 4032	35.9 × 24.0	23, 24, 25, 29, 47, 50, 59
	6K 1.85:1	6054 × 3272	36.0 × 19.4	23, 24, 25, 29, 47, 50, 59
	6K 17:9	6054 × 3192	36.0 × 19.0	23, 24, 25, 29, 47, 50, 59
	6K 2.39:1	6048 × 2534	35.9 × 15.0	23, 24, 25, 29, 47, 50, 59
	5.7K 16:9	5674 × 3192	33.7 × 18.9	23, 24, 25, 29, 50, 59
ANAMORPHIC LICENSE	4K 6:5	4096 × 3432	24.3 × 20.4	23, 24, 25, 29, 47, 50, 59
	4K 4:3	4096 × 3024	24.3 × 18.0	23, 24, 25, 29, 47, 50, 59
	4K 4:3 Surround View	4096 × 3024 (4552 × 3360)	24.3 × 18.0 (27.0 × 20.0)	23, 24, 25, 29
License not required <sup>1)</sup>	4K 17:9	4096 × 2160	24.3 × 12.8	23, 24, 25, 29, 47, 50, 59
	4K 17:9 Surround View	4096 × 2160 (4552 × 2400)	24.3 × 12.8 (27.0 × 14.3)	23, 24, 25, 29
	4K 2.39:1	4096 × 1716	24.3 × 10.3	23, 24, 25, 29, 47, 50, 59
	3.8K 16:9	3840 × 2160	22.8 × 12.8	23, 24, 25, 29, 50, 59
	3.8K 16:9 Surround View	3840 × 2160 (4268 × 2400)	22.8 × 12.8 (25.4 × 14.3)	23, 24, 25, 29

1) The Anamorphic License is required to enable ratio settings, other than Off(1.0×), for the de-squeeze function.

## Supported Shooting Frame Rates and De-Squeeze Values

The following table shows the supported shooting frame rates and De-Squeeze values (page 72) in each imager mode.

## [Note]

The following shows the supported shooting frame rates when the video format is X-OCN. For ProRes, the supported maximum shooting frame rates are different (page 44).

FULL-FRAME LICENSE

ANAMORPHIC LICENSE

## MPC-3628

Imager mode	Shooting frame rate	De-Squeeze						
		Off(1.0×)	1.25×	1.3×	1.5×	1.65×	1.8×	2.0×
8.6K 3:2	1 to 30	Yes	Yes	Yes	Yes	Yes	Yes	Yes
8.2K 17:9	1 to 60	Yes	Yes	-	Yes	Yes	Yes	Yes
7.6K 16:9	1 to 60	Yes	-	-	-	-	-	-
5.8K 6:5	1 to 48	Yes	-	-	-	-	-	Yes
5.8K 17:9	1 to 60, 66, 72, 75, 88, 90	Yes	Yes	-	Yes	Yes	Yes	Yes
5.4K 16:9	1 to 60, 66, 72, 75, 88, 90	Yes	-	-	-	-	-	-

## MPC-3626

Imager mode	Shooting frame rate	De-Squeeze						
		Off(1.0x)	1.25x	1.3x	1.5x	1.65x	1.8x	2.0x
6K 3:2	1 to 60	Yes	Yes	Yes	Yes	Yes	Yes	Yes
6K 1.85:1	1 to 60, 66, 72	Yes	-	-	-	-	-	-
6K 17:9	1 to 60, 66, 72	Yes	Yes	Yes	-	Yes	Yes	Yes
6K 2.39:1	1 to 60, 66, 72, 75, 88, 90	Yes	-	-	-	-	-	-
5.7K 16:9	1 to 60, 66, 72	Yes	-	-	-	-	-	-
4K 6:5	1 to 60, 66, 72	Yes	-	-	-	-	-	Yes
4K 4:3 Surround	1 to 30	Yes	-	Yes	-	Yes	Yes	Yes
4K 4:3	1 to 60, 66, 72, 75	Yes	-	Yes	-	Yes	Yes	Yes
4K 17:9 Surround	1 to 48	Yes	Yes	Yes	-	Yes	Yes	Yes
4K 17:9	1 to 60, 66, 72, 75, 88, 90, 96, 100, 110	Yes	Yes	Yes	-	Yes	Yes	Yes
4K 2.39:1	1 to 60, 66, 72, 75, 88, 90, 96, 100, 110, 120	Yes	-	-	-	-	-	-
3.8K 16:9 Surround	1 to 48	Yes	-	-	-	-	-	-
3.8K 16:9	1 to 60, 66, 72, 75, 88, 90, 96, 100, 110	Yes	-	-	-	-	-	-

## Surround View (MPC-3626)

Surround View is a mode available in the following imager modes that displays an image range that includes a 5% outer region beyond the effective picture size (top/bottom/left/right) in the viewfinder and SDI monitor output, allowing you to view a larger image range when shooting. The recorded image area does not include the outer region.

4K 4:3

4K 17:9

3.8K 16:9

## [Notes]

- In this mode, limitations on the maximum project frame rate setting may apply.
- In 4K 4:3 mode with de-squeeze ratio of 2.0x, the image area includes only 5% of the top and bottom outer regions.

# System Configuration

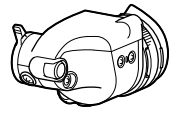

DVF-EL200  
Viewfinder  
(VF cable A-2203-745-A (supplied with unit) or 1-912-598-21 is required)

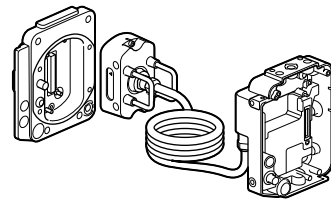

CBK-3610XS\*  
Camera Extension System

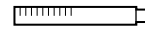

ECM-680S, ECM-678, ECM-674  
Microphone  
(EC-0.5X3F5M is required)

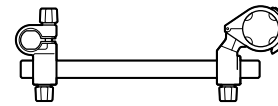

Microphone Holder base assembly (A-2182-620-B)  
Rod clamp (A-2182-621-B)  
Rod (4-684-612-01)  
Microphone Holder assembly (X-2596-733-2)  
Screws P2.6x8 (2) (7-627-556-98)



CBKZ-3620A,  
CBKZ-3620AM,  
CBKZ-3620AW  
ANAMORPHIC  
LICENSE

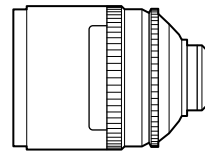

SCL-PK6,  
SCL-P11X15  
S35 PL Lens



CBKZ-3620F,  
CBKZ-3620FM,  
CBKZ-3620FW  
FULL-FRAME  
LICENSE

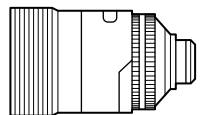

Anamorphic Lens  
(PL-mount / E-mount)

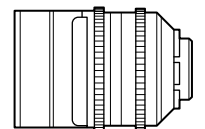

Full-Frame Lens  
(PL-mount / E-mount)

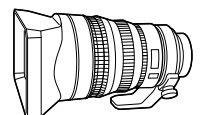

SEL28135G, SEL1224GM, SEL1635GM, SEL2470GM, SEL70200GM, SEL100400GM,  
SEL24F14GM, SEL35F14GM, SEL50F12GM, SEL85F14GM, SEL100F28GM  
E-mount lens

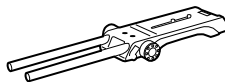

VCT-FSA5  
Shoulder Adaptor

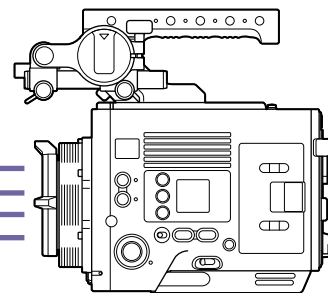

MPC-3628/  
MPC-3626

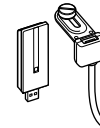

CBK-WA02  
5 GHz/2.4 GHz Wireless LAN  
Adaptor

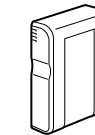

BP-GL95B  
Battery Pack



AXS-A512S24,  
AXS-A512S48,  
AXS-A1TS48,  
AXS-A1TS66  
AXS Memory Card

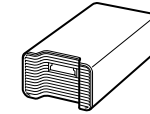

AXS-AR3  
AXS Memory Card  
Reader



RM-B170/B750  
RCP-1000/1500/1530/3100/3500  
RCP-1001/1501/3501  
Remote Control Unit



# Location and Function of Parts

## Operator Side

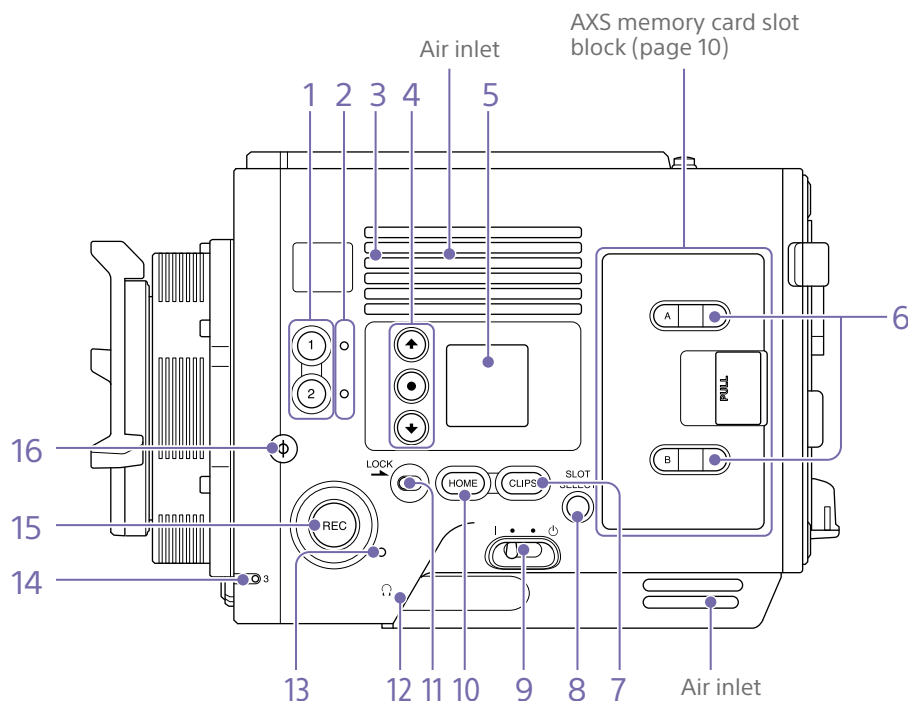

### [Note]

Do not operate with the air inlet blocked.

### 1. ASSIGN (assignable) buttons 1/2 (page 48)

Assign functions using the EDIT page of the user functions screen (page 48).

The assigned function toggles between on/off (enabled/disabled) or is activated with each press.

### 2. ASSIGN (assignable) lamps 1/2 (page 48)

The lamp is lit orange when the assigned function is on (enabled) or activated, and not lit when the function is off (disabled).

### 3. Built-in speaker

You can monitor the input audio during shooting/recording and playback sound during playback. The speaker also sounds alarms to reinforce visual warnings (page 95).

If you connect earphones to the headphones jack, the speaker output is suppressed automatically.

### [Note]

If configured such that the internal microphone captured sound is audible from the built-in speaker, howling may occur if the monitor volume is increased.

### 4. Mini display ITEM keys 1 to 3

Controls the operation of functions on the mini display (page 96).

### 5. Mini display

Displays various setup items, such as shutter angle, that you can check or modify (page 96).

### 6. ACCESS lamps (SLOT A/B)

Each lamp is lit when the recording media in AXS card slot A/B is the target for recording/playback and when data is being written to or read from the recording media in AXS card slot A/B (page 26).

### 7. CLIPS button

Press to display the clip screen on the mini display to enable clip operations (page 99). Simultaneously, the clip list screen is displayed on the sub display and can also be used for clip operations.

To switch from playback mode to shooting mode, press the HOME button.

### 8. SLOT SELECT (AXS memory card select) button

Press to switch the active slot.

### 9. Power switch

Set to the I (ON) position to turn the power on. Set to the  $\text{O}$  (OFF) position to turn the power off.

### [Notes]

- This unit uses a small amount of standby power even when the power switch is set to OFF. Remove the battery pack if the unit will not be used for a prolonged period.
- When removing the battery pack or the DC IN power, be sure to first set the power switch to the OFF position. Interrupting the power supply during recording or during memory card access could cause a malfunction.

### 10. HOME button

Press to clear the item selection display and return to the Home screen on the mini display. If pressed when the unit is in playback state, the unit transitions to shooting mode (page 96).

### 11. LOCK switch

Locks the operation of the buttons on the Operator side. When locked, the switch background LED lights in orange.

### 12. Headphones connector (stereo mini jack)

Connect to earphones for audio monitoring. You can monitor the input audio during shooting/recording and playback sound during playback (page 95).

### [Notes]

- Use monaural (2-pole) or stereo (3-pole) type earphones. The use of other devices may damage the unit.
- Use 16-ohm impedance earphones.

### 13. REC ACTIVE lamp

The lamp is lit green when the REC button is enabled.

### 14. ASSIGN (assignable) lamp 3 (page 48)

The lamp is lit orange when the assigned function is on (enabled) or activated, and not lit when the function is off (disabled).

### 15. REC (recording start/stop) button/lamp

Press to start recording, turning the REC lamp on. Press again to stop recording, turning the REC lamp off (page 107).

The REC lamp flashes when a device error or warning occurs.

### 16. $\Phi$ (phi) mark

The  $\Phi$  (phi) mark is on the same plane as the image sensor.

To measure the precise distance between the unit and the subject, use the  $\Phi$  (phi) mark as a reference.

## AXS memory card slot block (page 26)

The AXS memory card slots are located behind the cover.

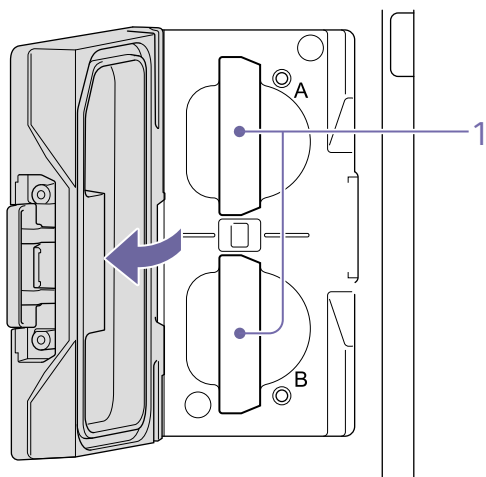

1. AXS memory card slots A/B

## Assistant Side

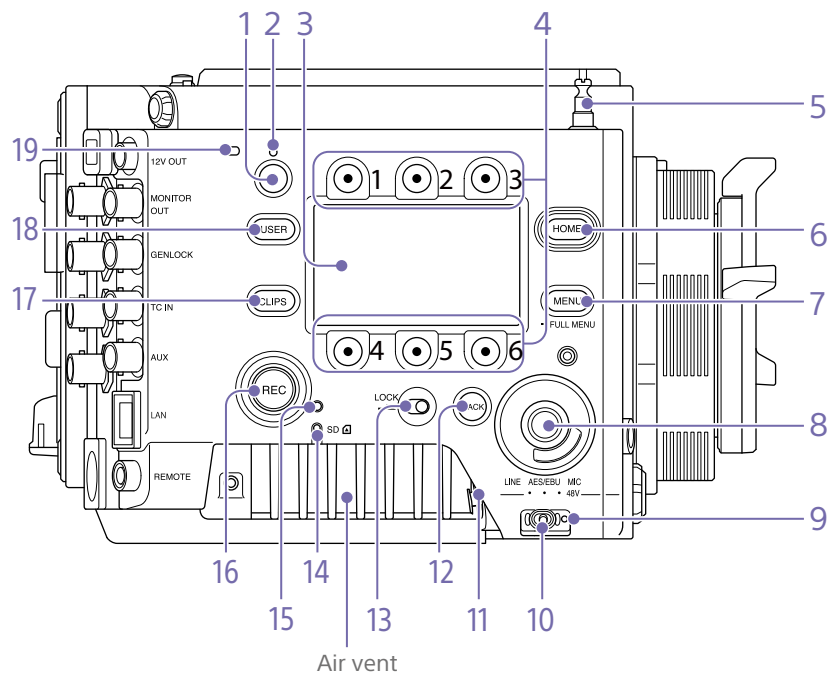

### 1. ASSIGN (assignable) button 4 (page 48)

Assign functions using the EDIT page of the user functions screen (page 48). The assigned function toggles between on/off (enabled/disabled) or is activated with each press.

### 2. ASSIGN (assignable) lamp 4 (page 48)

The lamp is lit orange when the assigned function is on (enabled) or activated, and not lit when the function is off (disabled).

### 3. Sub display

Allows you to check the operation status of the unit and make various settings (page 36). With the Home screen displayed, press and hold the BACK button (page 11) and turn

the MENU dial to adjust the brightness of the sub display and mini display. The brightness can also be adjusted using Technical > Panel Control > Brightness level (page 89) in the full menu.

### 4. Sub display ITEM keys 1 to 6

Controls the operation of functions on the sub display (page 54).

### 5. Tape measure hook

The tape measure hook is on the same plane as the image sensor. To measure the precise distance between the unit and the subject, use the tape measure hook as a reference. You can attach the end of a tape measure to the hook, and measure the distance from the subject.

### 6. HOME button

Press to clear the display and return to the Home screen on the sub display (page 38). If pressed when the unit is in playback state, the unit transitions to shooting mode.

### 7. MENU (menu display on/off) button (pages 54, 64)

Press the MENU button to display the menu screen on the sub display. Press and hold the MENU button for 2 seconds or longer to display the full menu screen on the sub display.

You can also press the MENU button together with the MENU dial to quickly display the full menu screen.

Press the button during menu screen or full menu screen display to return to the previous screen display.

### 8. SEL/SET (select/set) dial (MENU dial)

Changes the item selection or a setting within the menu (pages 38, 54, 64).

### 9. +48V power lamp

Lights in green if the AUDIO IN switch is set to MIC and +48 V phantom power is supplied on the AUDIO IN connector. It is not lit if phantom power is not supplied.

You can turn +48 V phantom power on/off using Audio category > Audio Details > Audio Configuration > Phantom Power +48V (page 84) in the menu.

### 10. AUDIO IN (audio selector) switch

Select the input signal type corresponding to the audio source connected to the AUDIO IN connector.

LINE: When connecting an external analog audio signal source

AES/EBU: When connecting an external digital audio signal source

MIC: When connecting a microphone

**11. AUDIO IN connector (XLR 5-pin)**

Input external microphone or audio equipment signals.

When the audio source is set to LINE or MIC using the AUDIO IN switch, this connector functions as an AUDIO IN CH-1 and AUDIO IN CH-2 connector.

When the audio source is set to AES/EBU using the AUDIO IN switch, this connector functions as the AUDIO IN CH-1/2 and AUDIO IN CH-3/4 connector.

**12. BACK button**

Cancels the menu setting and moves up one level in the menu hierarchy during menu display. Cancels the execution process or pending process during process execution/pending display (pages 38, 54, 64).

**13. LOCK switch**

Locks the operation of the buttons on the Assistant side. When locked, the switch background LED lights in orange.

**14. ACCESS (SD card access) lamp (page 34)****15. REC ACTIVE lamp**

The lamp is lit green when the REC button is enabled.

**16. REC (recording start/stop) button/lamp**

Press to start recording, turning the REC lamp on. Press again to stop recording, turning the REC lamp off (page 107).

The REC lamp flashes when a device error or warning occurs.

**17. CLIPS button**

Press to display the clip list screen on the sub display to enable clip operations (page 93). Simultaneously, the clip screen is displayed on the mini display.

To switch from playback mode to shooting mode, press the HOME button.

**18. USER button**

Press to display the user function list on the sub display, and to operate the ITEM keys 1 to 5 user function buttons.

ITEM key 6 is the user function list EDIT button. Press this button to display the function selection screen for the user function buttons and assignable buttons. Press again when the user functions screen is displayed to return to the previous display (page 48).

**19. Internal microphone**

Use to record audio.

Select the input channel for the internal microphone using Audio > Audio Input > Internal Mic Select (page 84) in the full menu.

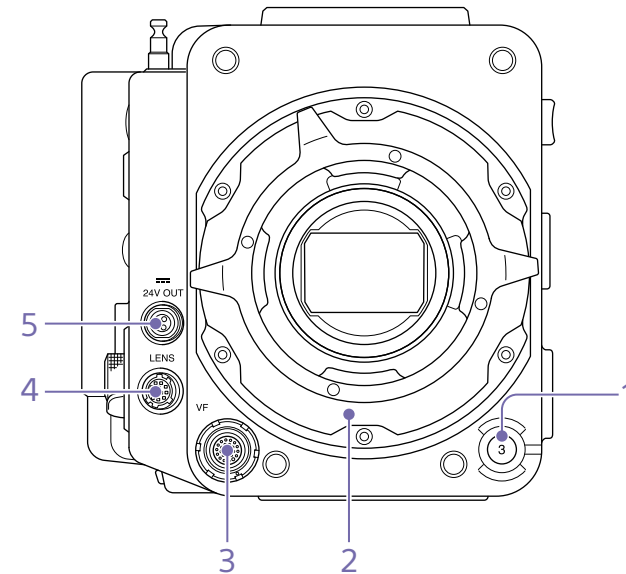
**Front****1. ASSIGN (assignable) button 3 (page 48)**

Assign functions using the EDIT page of the user functions screen (page 48). The assigned function toggles between on/off (enabled/disabled) or is activated with each press.

**2. PL lens mount adaptor (page 21)****3. VF (viewfinder output) connector (page 24)****4. LENS connector (12-pin)**

Supports iris, focus, and zoom control from a network-connected computer, smartphone, or tablet.

**5. 24V OUT connector (24 V DC output, Fischer 3-pin)**

24 V DC power supply output connector (page 120).

The output voltage and maximum output current of this connector vary depending on

the input voltage to the unit. The maximum current includes the output current from the 24V OUT connector on the rear panel (page 12).

**11 V to 17 V input**

Output voltage: 24 V

Maximum output current: 1.0 A

**22 V to 32 V input**

Output voltage: Same as the input voltage

Maximum output current: 2.0 A

## Rear

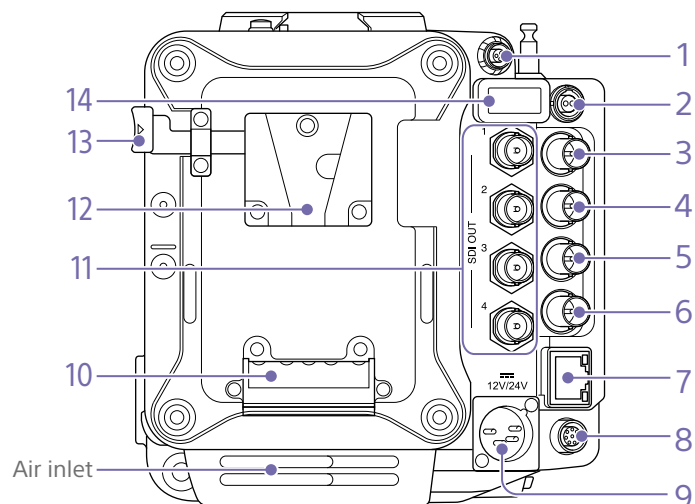
**[Note]**

Do not operate with the air inlet blocked.

**1. 24V OUT connector (24 V DC output, Fischer 3-pin)**

24 V DC power supply output connector (page 120).

The output voltage and maximum output current of this connector vary depending on the input voltage to the unit. The maximum current includes the output current from the 24V OUT connector on the front panel (page 11).

**11 V to 17 V input**

Output voltage: 24 V

Maximum output current: 1.0 A

**22 V to 32 V input**

Output voltage: Same as the input voltage

Maximum output current: 2.0 A

**2. 12V OUT connector (12 V DC output, LEMO 2-pin)**

12 V DC power supply output connector (page 120).

The output voltage and maximum output current of this connector vary depending on the input voltage to the unit.

**11 V to 17 V input**

Output voltage: Same as the input voltage

Maximum output current: 1.0 A

**22 V to 32 V input**

Output voltage: 16.8 V

Maximum output current: 1.0 A

**3. MONITOR OUT connector (BNC type)**

HD SDI monitor signal output connector (page 120).

**4. GENLOCK (genlock input) connector (BNC type)**

To genlock the unit to an external source or to lock the timecode of the unit to an external source, input an external reference signal. Digital signal and analog signal input are supported.

Digital signal: 1.5G HDSDI interlaced/progressive signal

Analog signal: HD sync, SD sync

**5. TC IN (timecode input) connector (BNC type)**

To lock the timecode of the unit to an external source, input a reference timecode signal.

**6. AUX connector (BNC type)**

Outputs the timecode signal (page 120).

**7. Network connector (RJ-45)**

Connect to a wired LAN network using a LAN cable (not supplied) for remote control of the unit (page 100).

**8. REMOTE (remote control) connector (8-pin)**

Connect to a remote control unit or other external control device.

**9. 12V/24V (DC power input) connector (page 17)**

DC power supply input connector for external power supply to the unit. Supports 12 V and 24 V input voltages.

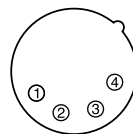

No.	Signal
1	GND
2	NC
3	NC
4	DC IN (11 V to 17 V or 22 V to 32 V)

**10. Battery attachment terminal (page 17)**

**11. SDI OUT 1 to 4 (serial digital output) connectors (BNC type) (page 120)**

**12. Battery pack mount (page 17)**

**13. Battery release lever (page 17)**

**14. HDMI OUT connector (page 120)**

## Top

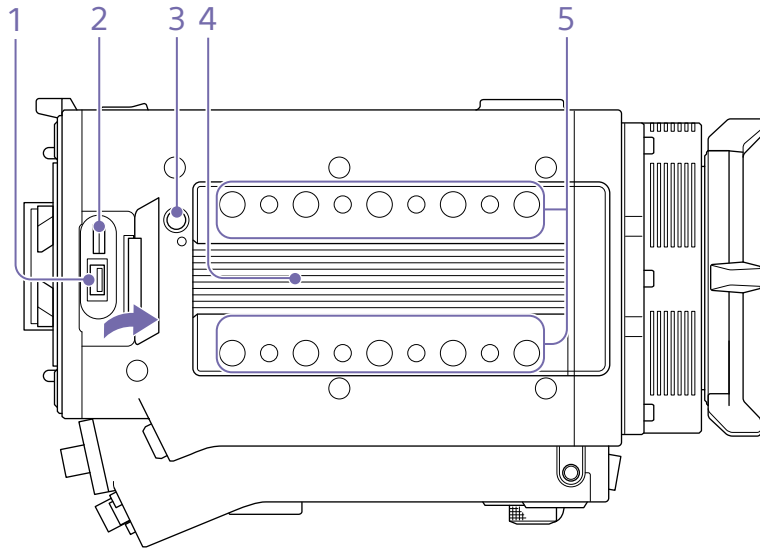
**1. External device connector**

Used for camera wireless remote control (page 100) by connecting a CBK-WA02 Wireless LAN Adaptor (option).

**2. Manufacturer calibration terminal**

Manufacturer terminal for calibration and servicing (cannot be used by users).

**3. Release button (page 20)****4. Handle/VF attachment mount (page 20)****5. Accessory mounting screw holes**

Type of screw: 1/4-20UNC (8)

Type of screw: 3/8-16UNC (10)

Length of engagement: 10 mm ( $\frac{13}{32}$  inch) or less

## Bottom

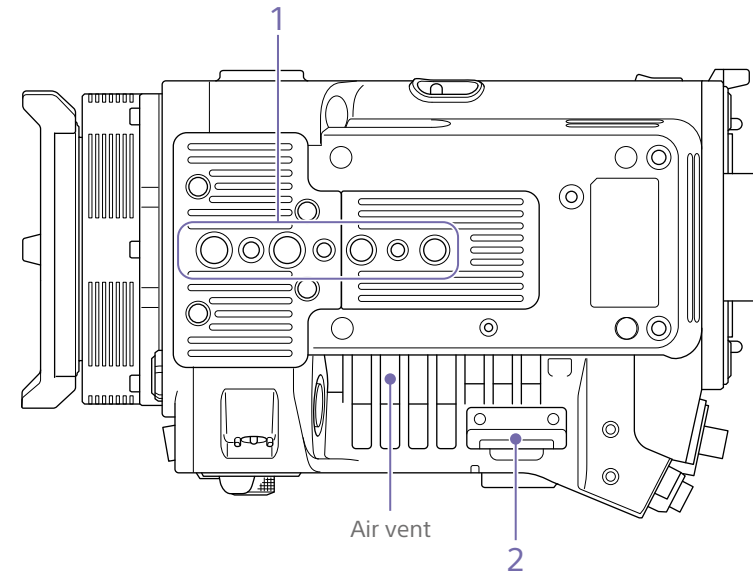
**1. Tripod plate attachment holes**

Type of screw: 1/4-20UNC (2)

Type of screw: 3/8-16UNC (4)

Length of engagement: 9 mm ( $\frac{3}{8}$  inch) or less

**2. SD card slot (page 34)**

## Viewfinder/Monitor Screen

During shooting (recording or standby) and playback, the information selected in Monitoring > Overlays/Frame Line > Overlay A/B Setup (page 79) in the full menu is displayed.

### Information displayed on the screen while recording

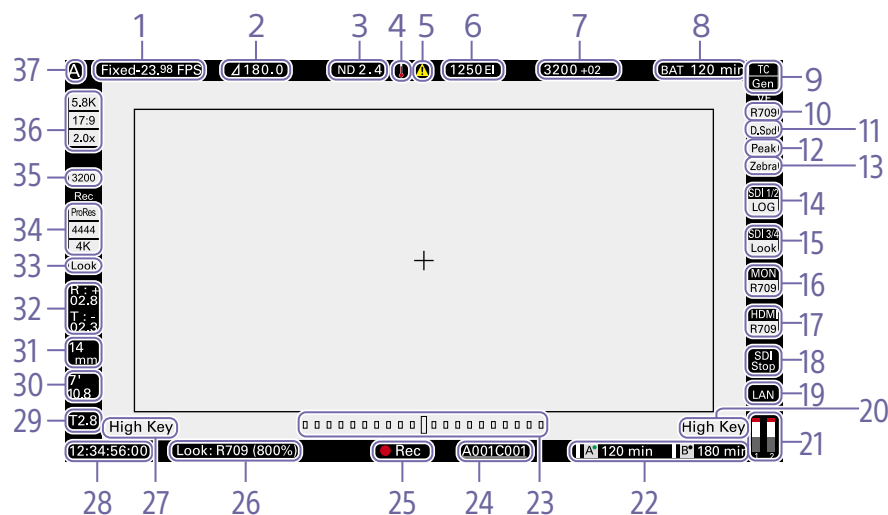

#### 1. Recording frame rate indicator

Displays the recording frame rate and project frame rate.

1.2 (1/16)

1.5 (1/32)

1.8 (1/64)

2.1 (1/128)

2.4 (1/256)

#### 2. Shutter angle/shutter speed indicator

Displays the shutter angle or shutter speed of the electronic shutter, according to the Technical > System Configuration (page 87) setting in the full menu.

#### 4. Thermometer icon

Displayed when a high temperature warning message is issued.

The description is displayed in the Info category in the menu.

#### 3. ND filter indicator

Displays the density of the ND filter. The display value is a LOG (base 10) value (page 66).

CLEAR

0.3 (1/2)

0.6 (1/4)

0.9 (1/8)

#### 5. Warning icon

Displayed when other than a high temperature warning message is issued.

The description is displayed in the Info category in the menu.

#### 6. Exposure index (EI)/gain indicator

Displays the EI value, or the gain value (dB units) set by an RM-B170 or other remote control unit.

#### [Note]

The gain value is displayed only when Technical > Special Configuration > RM/RCP Paint Control (page 91) is set to On in the full menu.

#### 7. Color temperature indicator

Displays the color temperature and Tint value of the white balance.

#### 8. Battery capacity/voltage indicator

Displays the following indicators according to the type of battery power source.

Battery type	Display
Sony Info battery	Battery remaining capacity and remaining recording time
Anton/Bauer battery	Remaining battery capacity (% indicator)
Other batteries	Input voltage

#### 9. Timecode external lock indicator/Genlock status indicator

Displays locked status when the timecode is locked to an external source. Displays locked status when genlocked.

#### 10. VF LUT indicator

Displays the viewfinder LUT (page 70).

#### 11. VF Double Speed Scan indicator

Displays the on/off state of the function for doubling the frame rate of the viewfinder display.

#### 12. VF Peaking indicator

Displays the on/off state of the peaking function of the viewfinder display.

#### 13. VF Zebra indicator

Displays the on/off state of the zebra function of the viewfinder display (page 52).

#### 14. SDI OUT 1/2 connector LUT indicator

Displays the LUT setting of the SDI OUT 1/2 connectors (page 68).

#### 15. SDI OUT 3/4 connector LUT indicator

Displays the LUT setting of the SDI OUT 3/4 connectors (page 69).

#### 16. Monitor LUT indicator

Displays the LUT setting of the Monitor output (page 69).

#### 17. HDMI LUT indicator

Displays the LUT setting of the HDMI output (page 70).

**18. SDI output REC trigger indicator**

Displays the SDI output REC trigger status.

State	Display	
Technical > System Configuration > SDI Rec Remote Trigger in the full menu	Recording command superimposed on the SDI output	
Off	-	(Blank)
HD SDI Remote I/F	Stop command	Top: SDI Bottom: Stop
	Rec command	Top: SDI Bottom: REC
Parallel Rec	Stop command	Top: SDI-P Bottom: Stop
	Rec command	Top: SDI-P Bottom: REC

**19. Network connection status indicator**

Displays the network connection status (LAN or Wi-Fi).

State	Display
Disconnected or other error (valid network connection settings)	Flashing
Connected (valid network connection settings)	On
Network connection function not used	Blank

**20. High Key/Low Key indicator (Monitor output)**

Displayed when the Monitor output is High Key (screen for checking blown-out highlights) or Low Key (screen for checking blocked-out shadows) (displayed for Monitor Out output).



**21. Audio level meter indicators**

Displays the levels of audio channels 1 and 2 while recording.

**22. Recording media state/remaining capacity indicator for each media slot**

Displays the state and remaining capacity of the media in AXS memory card slots A/B.

A  (recording active) icon on the left of "AXS" indicates the recording target media.

An indicator  (active slot icon) on the upper right of the slot A/B icon on the right of "AXS" indicates the playback target media (green indicator indicates media is being played). A  (warning) icon is displayed for media if a condition occurs that could impact recording.

**23. Spirit level gauge graphical indicator**

Displays the horizontal tilt of the unit in  $\pm 0.1^\circ$  increments, up to  $\pm 10^\circ$ .

You can adjust the zero angle alignment of the spirit level gauge by executing Technical > Special Configuration > Level Gauge Adjust (page 87) in the full menu.





**24. Clip name display**

Displays the first 8 characters of the name of the next clip to be recorded in recording standby mode.

Displays the first 8 characters of the name of the clip currently being recorded when recording.

**25. Recording status indicator**

Displays the following recording operation states of the unit.

Display	Description
 Rec (Rec)	Recording
 Stby (Stby)	Recording standby
 Cache (Cache)	Picture cache recording standby
 CALL (CALL)	CALL command incoming

When Monitoring > Overlays/Frame Line > VF, SDI 1/2, SDI 3/4, Monitor, or HDMI > Overlay (page 79) is set to Rec Ind. in the full menu, the information display for the configured output destination is set to display only the recording operation status.

**26. Look information display**

Displays the selected Look (page 67).

**27. High Key/Low Key indicator (viewfinder output)**

Displayed when the viewfinder output is High Key (screen for checking blown-out highlights) or Low Key (screen for checking blocked-out shadows) (displayed for viewfinder output).

**28. Time data display**

Displays the duration or timecode, depending on the TC/Media category > TC Display setting in the menu (page 56).

**29. Iris position indicator**

Displays the iris position (only when a lens that is compatible with the iris setting display function is attached). The iris position indicator displays in 1/3 stop increments when using an E-mount lens.

**[Note]**

The F-stop value is displayed instead of the T-stop value if the T-stop value cannot be obtained.

**30. Focus position indicator**

Displays the focus position (only when a lens that is compatible with the focus setting display function is attached).

**31. Zoom position indicator**

Displays the focal length of the zoom (displayed only when a lens that supports the zoom setting indicator is attached).

**32. Spirit level indicator**

Displays horizontal level information numerically.

R (Roll) indicates the left-to-right horizontal tilt of the unit.

T (Tilt) indicates the front-to-rear vertical tilt of the unit.

You can adjust the zero angle alignment of the spirit level gauge by executing Technical > Special Configuration > Level Gauge Adjust (page 87) in the full menu.

**33. Recording LUT indicator**

Displays the LUT setting for recording.

**34. Recording media format (codec) indicator**

Displays the format of the recording on an AXS memory card.

**35. Base ISO indicator**

Displays the configured base sensitivity.

**36. Effective picture size indicator**

Displays the effective picture size and whether anamorphic de-squeeze conversion is applied, set using Project category > Imager Mode in the menu. In Surround View mode, a "Sur.V" icon is displayed below the anamorphic conversion ratio icon (page 54).

A "Z 17:9" icon is displayed when Project category > Zoom to Fit (page 55) is set to 17:9 in the menu. A "Z 16:9" icon is displayed when Zoom to Fit is set to 16:9.

**37. Camera ID indicator**

Displays the Camera ID setting (page 76).

## Menu display and settings on the viewfinder screen

When a DVF-EL200 is attached to the unit, press and hold the Menu button on the DVF-EL200 to display the Monitoring > VF Display (page 78) and VF Function (page 78) setup menus on the viewfinder screen. This allows you to configure these functions while viewing the viewfinder screen.

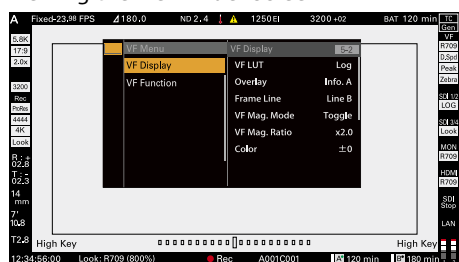

## Information displayed on the playback screen

The following information is displayed on the playback picture.

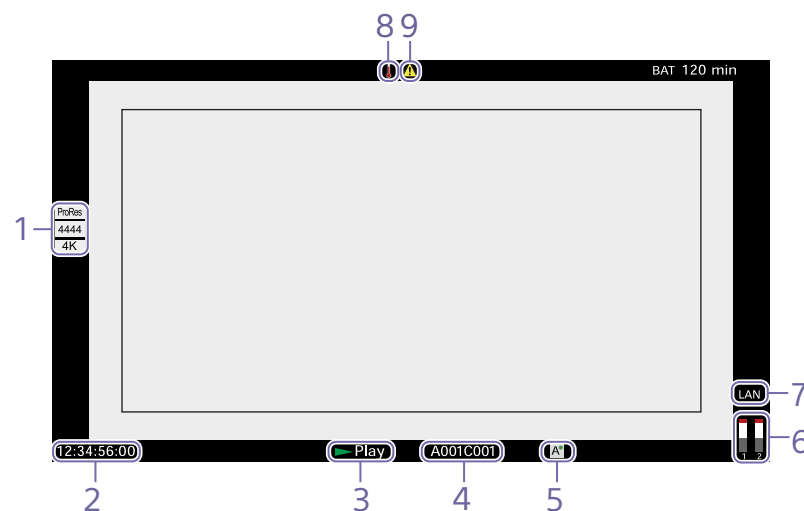

**1. Playback media format (codec) indicator**  
Displays the recording format (codec) of the playback clip.

**2. Time data display**  
Displays the duration or timecode, depending on the TC/Media category > TC Display setting in the menu (page 56).

**3. Playback status indicator**  
Displays the playback status.  
Displays "CALL" when a CALL command is received.

**4. Playback clip name display**  
Displays the first 8 characters of the name of the playback clip.

**5. Playback media indicator**  
Displays the type of recording media being played.  
A  (protect) icon appears on the right if the memory card is write-protected.

**6. Audio level meter indicators**  
Displays the levels of audio channels 1 and 2 during playback.

**7. Network connection status indicator**  
Displays the network connection status (LAN or Wi-Fi).

State	Display
Disconnected or other error (valid network connection settings)	Flashing
Connected (valid network connection settings)	On
Network connection function not used	Blank

**8. Thermometer icon**  
Displayed when a high temperature warning message is issued.  
The description is displayed in the Info category in the menu.

**9. Warning icon**  
Displayed when other than a high temperature warning message is issued.  
The description is displayed in the Info category in the menu.



# Preparing a Power Supply

You can use a battery pack or AC power via an AC adaptor.

For safety, use only the Sony battery packs listed below.

## Lithium-ion battery pack

BP-GL95B

## AC adaptor

Adaptor that has a rating of 120 W or higher.

## Using a Battery Pack

Insert the battery pack into the battery pack mount (page 12) of the battery adaptor, then slide the battery pack down to lock it in place.

To remove it, unlock the battery pack by sliding it up while pressing the battery release lever (page 12), then remove it.

### [Notes]

- Before use, charge the battery pack with the battery charger.
- A warm battery pack immediately after use may not be able to be fully recharged.
- Remove the battery adaptor while supporting the unit by hand.

## Checking the remaining battery charge

When recording or playback is in progress using the battery pack, the current battery remaining time and battery voltage are displayed on the sub display screen (page 36) and viewfinder/monitor screen (page 14).

The unit indicates the remaining usage time in minutes by calculating the available time with the battery pack if operation is continued at the current rate of power consumption.

## If the remaining battery charge becomes low

If the remaining battery charge decreases to a certain level during operation, the remaining battery capacity indicator flashes and the REC lamp flashes to warn you.

If the remaining charge further decreases to a level at which operation cannot be continued, a battery-empty message appears.

Replace the battery pack with one that is fully charged.

## To change the message levels

Change levels using Technical > Batt./Voltage Alarm (page 89) in the full menu.

## Using AC Power (DC IN Power)

The unit works with AC power using a 120 W AC adaptor.

11 V to 17 V and 22 V to 32 V input voltage ranges are supported.

### [Notes]

- When switching to the DC IN power supply during battery operation, use a power supply with a voltage in the range 12 V to 17 V for safer power supply switching.
- When using a 22 V to 32 V power supply, it is recommended that you first set the power switch to the OFF position before connecting the power supply.
- Do not switch the DC IN power supply voltage directly from a 11 V to 17 V power supply to a 22 V to 32 V power supply, or vice versa. This may cause a malfunction.

## Using a Battery Pack and DC IN Power Supply Together

Whenever an active power supply is applied using a battery pack and a DC IN power supply, the DC IN power supply takes precedence.

### [Note]

When the power supply switches from battery operation to the DC IN power supply, operation of the unit may stop if the following occurs.

- Chattering of the connector contacts when inserting the DC connector
- Voltage drop when switching between power supplies (more prevalent when the external load is greater)

# Setting the Clock

When you use the unit for the first time, the initial setup screen appears on the sub display when the power is turned on.

Set the date and time of the built-in clock using this display.

---

## Time Zone

---

The value shows the time difference from UTC (Coordinated Universal Time). Change the setting if needed.

### [Note]

When Time Zone is changed, the clock setting changes according to the time difference.

---

## Setting the Date and Time

---

Turn the MENU dial (page 10) to move the cursor, then press the MENU dial to set each menu item. When you press the MENU dial when the cursor is on "Set," the setting display disappears and the clock setting is completed. After the initial setup screen disappears, you can change Time Zone and date/time settings using Maintenance > Clock Set (page 92) in the full menu.

### [Notes]

- If the clock setting is cleared because the backup battery fully discharged when no power was supplied (no battery pack and no DC IN connection), the initial setup display will be displayed when you next turn the unit on.
- While the initial setup display is shown, no other operation, except turning the power off, is permitted until you finish the setting for this display.

# Interchanging the Imager Block

You can interchange the imager block. This section describes the procedure for interchanging the 8K imager block with the 6K imager block as an example.

When attaching the 6K imager block, attach the cover (MPC-3628: accessory, MPC-3626: attached) for the 6K imager block.

## [Note]

Before interchanging the imager block, turn off the power for at least 10 minutes to allow the unit to cool. Also, be careful of sharp edges when interchanging the imager block.

- 1 Remove the two hex screws on the bottom and four hex screws on the front, and remove the 8K imager block.

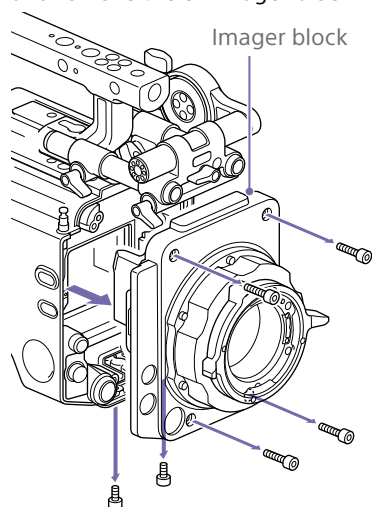

- 2 Attach the cover for the 6K imager block with the side with engraved text facing forward, and tighten with two screws (tightening torque: 0.19 N·m).

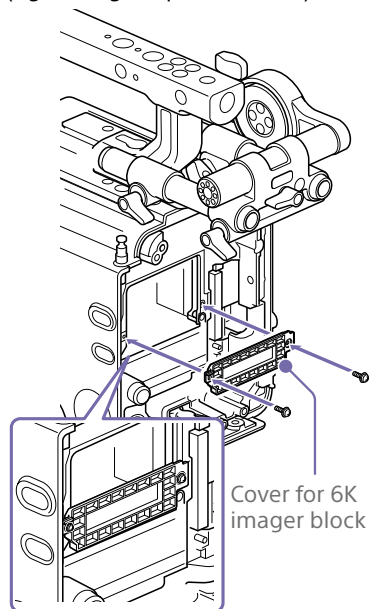

## [Notes]

- If the cover for the 6K imager block is not attached, the heat dissipation of the 6K imager block will become poor.
- Remove the cover for the 6K imager block when attaching the 8K imager block.

- 3 Attach the 6K imager block.

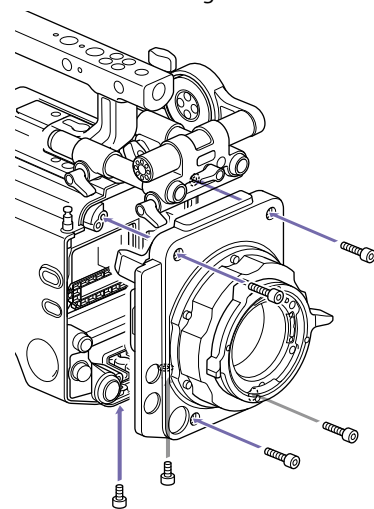

Make sure the imager block is straight, and tighten the six hex screws removed in step 1 (tightening torque: 1.4 N·m).

## Rebooting After Interchanging the Imager Block

When the unit is turned on for the first time after interchanging the imager block, startup will take a bit longer because the unit needs to reload sensor-specific data. The unit will reboot automatically a few minutes after being turned on when the sensor-specific data has finished loading.

# Attaching the VF Attachment and Handle

## Attaching the VF Attachment

- 1 Slide the VF attachment on in the direction of the arrow to attach it.
- 2 Position the VF attachment in the desired front/rear position, then turn the lock lever to secure it in position.

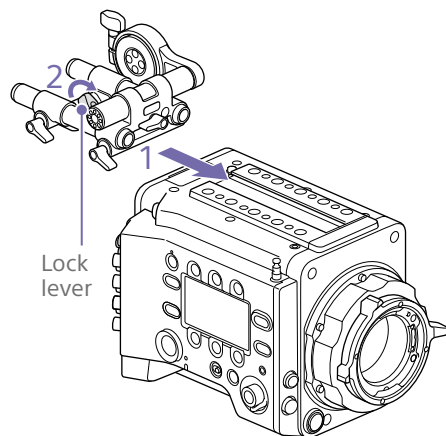

### [Notes]

- You can also attach the VF attachment in the front/rear or left/right orientation.
- If the lock lever is difficult to tighten or loosen, you can use a hex wrench (3 mm) on the lock screw on the top of the lock lever.

## To remove the VF attachment

Turn the lock lever to loosen, press the release button and slide the VF attachment off in the reverse direction from when attaching it.

## Attaching the Handle

- 1 Slide the handle on in the direction of the arrow to attach it.
- 2 Position the handle in the desired front/rear position, then turn the lock lever to secure it in position.

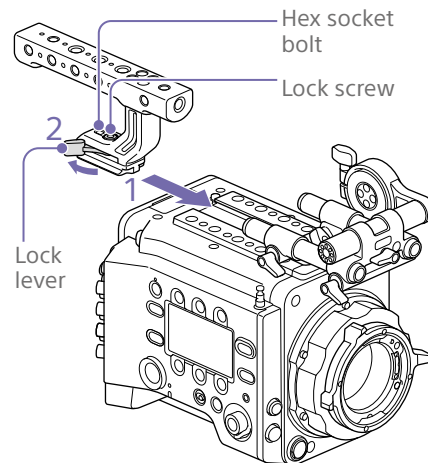

### [Notes]

- You can also attach a lock screw using a hex wrench (5 mm) to secure it in position.
- If the lock lever on the handle becomes loose during use, you can secure the handle by tightening a hex socket bolt (2 mm) beside the lock screw.
- You can also attach the handle in the reverse orientation.

## To remove the handle

Turn the lock lever to loosen, press the release button and slide the handle off in the reverse direction from when attaching it.

# Mounting a Lens and Adjusting the Flange Focal Length

## Recommended PL-mount lens (Super 35mm size)

SCL-PK6/F, SCL-PK6/M (set of 6 lenses, 20 mm/25 mm/35 mm/50 mm/85 mm/135 mm)

SCL-PK3/F, SCL-PK3/M (set of 3 lenses, 20 mm/25 mm/135 mm)

SCL-P11X15

## Recommended E-mount lens

SELP28135G, SEL1635GM, SEL2470GM, SEL70200GM, SEL100400GM, SEL1224G, SEL35F14Z, SEL50F14Z, SEL85F14GM, SEL90M28G, SEL100F28GM

### [Note]

Control may not be supported with some E-mount lenses. Use a recommended lens.

For details about available lenses for the unit, contact a Sony service representative.

### [CAUTION]

Do not leave the lens facing the sun. Direct sunlight can enter through the lens, be focused in the unit, and cause fire.

### [Notes]

- Turn the unit off before attaching or removing the lens and adapter.
- A lens is a precision part. Do not place the lens down with the mount side facing down. Attach the cap supplied with the lens.
- The lens interface of the unit is configured by factory default for an SCL-P11X15 and lenses with Cooke type connector. To use an SCL-PK6, SCL-PK3, or other lenses that do not have a Cooke type connector, set Technical > Lens Configuration > PL-Mt Interface Position (page 87) to Off in the full menu.

## Attaching a PL-Mount Lens

- 1 Remove the mount cover from the lens mount by turning the PL-mount lever counterclockwise.

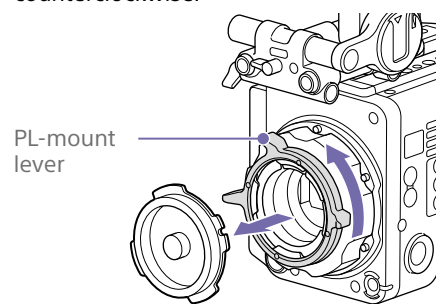

### [Note]

Turn the PL-mount lever counterclockwise to the stopper position.

- 2 Insert the lens into the lens mount by aligning the concave part of the lens with the positioning pin on the upper right of the lens mount.

- 3 Secure the lens by turning the PL-mount lever clockwise while holding the lens.

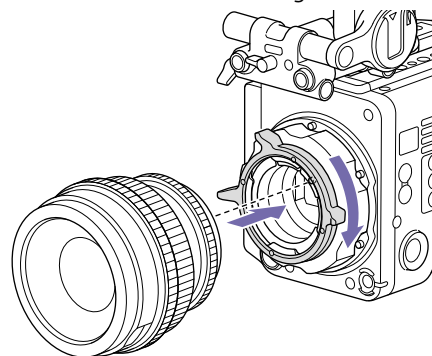

### [Note]

Do not turn the lens when attaching the PL-mount lens. It may cause damage to the hot shoe pin.

## To attach a Cooke /i lens

Align the contacts on the lens with the hot shoe of the unit. There are two connectors on the side of the lens adaptor, and either can be used.

## To remove the lens

- 1 Turn the PL-mount lever counterclockwise while holding the lens from underneath.

- 2 Pull the lens forward.

### [Notes]

- If another lens will not be attached soon, carefully align the concave part of the mount cover, then secure the mount cover by turning the PL-mount lever clockwise.
- For correct I/F communication with the lens, set the Technical > Lens Configuration (page 87) settings in the full menu to match the lens in use.

## Adjusting the Flange Focal Length

The unit is shipped with the flange focal length already adjusted. If you need to adjust the flange focal length, remove the lens mount, and change the shims with those of the appropriate thickness. You can adjust the thickness by  $\pm 0.1$  mm in 0.01 mm increments.

## Shims

The following shims are supplied with the unit.  
 0.05 mm  $\times$  1 (circular)  
 0.01 mm  $\times$  15 (1/3 arc)  
 1/3 arc shims should always be used as a set of three shims. Insert shims to increase the flange focal length. The unit is shipped with the flange focal length already adjusted using the following three types of shims.

0.10 mm (circular)

0.05 mm (circular)

0.01 mm (1/3 arc)

A seal is attached showing the shim thickness when shipped.

## Adjusting the flange focal length

- 1 Remove the six Torx screws and remove the PL-mount flange.

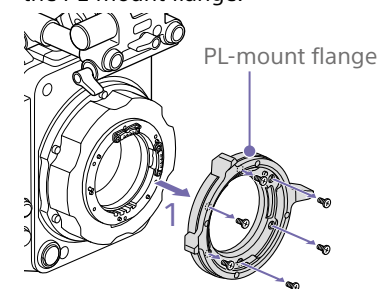

- 2 Loosen the four Phillips screws on both sides of the PL connectors (two locations), and remove the PL connectors and PL connector plates.

- 3 Attach shims to the PL-mount adaptor (three locations).

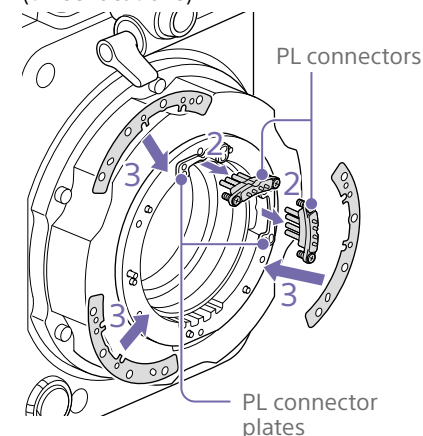

**When using 1/3 arc shims**

Attach shims so that they have the same thickness in all three locations.

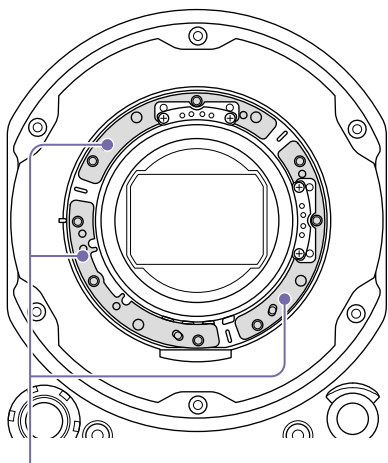

Shims

**When using circular shims**

Attach with the surface that has markings on it facing the front.

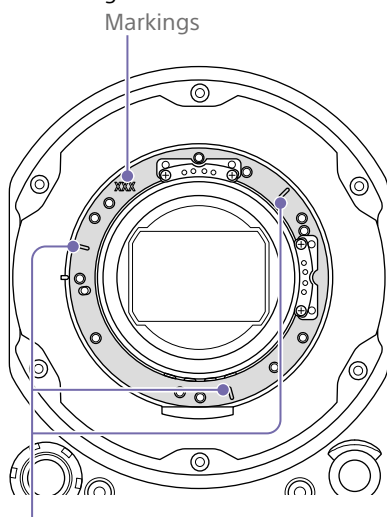

Markings

- 4 Reattach the PL connectors (two locations) to their original positions, and tighten the four Phillips screws with 0.18 N·m tightening torque.
- 5 Reattach the PL-mount flange in its original position, and tighten the six Torx screws to a tightening torque of 0.35 N·m using a T8 torque wrench.

**Cleaning the Filter**

To clean the filter, first remove the adaptor. Exercise care when wiping the adaptor center part (shaded part) with a cloth or other material to prevent fibers adhering to surfaces. If fibers are adhering, wipe off using a soft brush.

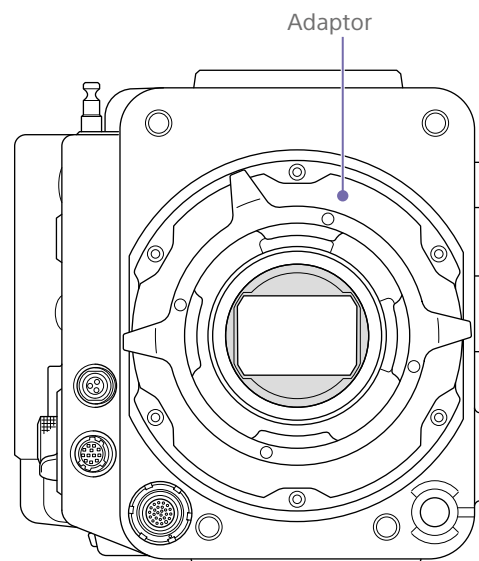
**Removing the PL Lens Adaptor**

Remove the PL lens adaptor when you want to mount an E-mount lens to the unit. Attachment/removal is performed with the rear side of the unit facing down. Loosen the six hex screws (2.5 mm) and remove the PL lens adaptor.

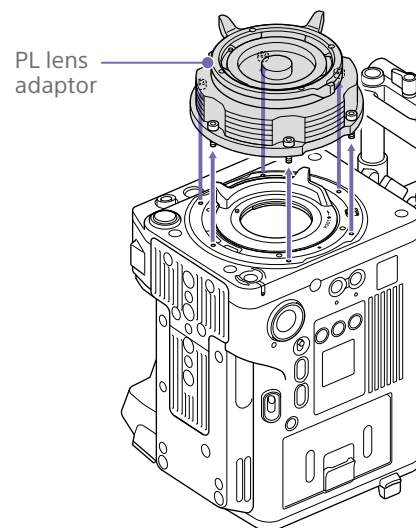
**[Notes]**

- Removing the battery and placing the rear side of the unit face down provides stability.
- When attaching/removing the adaptor, take care not to touch the connector contacts of the unit and PL lens adaptor.

**To attach the PL lens adaptor**

- 1 Check that the mount lever is in the locked position.

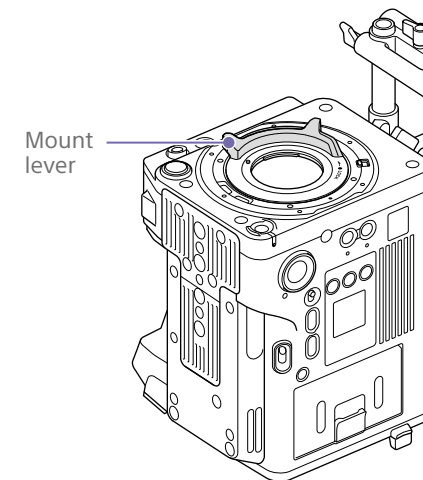

- 2 Place the PL lens adaptor back in its original position, insert the six hex screws (2.5 mm), and tighten the screws to a tightening torque of  $0.8 \pm 0.12$  N·m using a hex wrench (2.5 mm).

## Attaching an E-Mount Lens

- 1 Remove the PL lens adaptor (page 22).
- 2 Push the lock switch up, and turn the mount lever clockwise to release the lock.

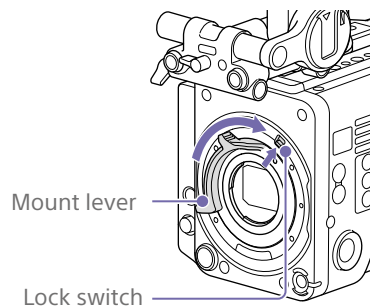

- 3 Align the mounting marks (white) on the unit and lens mount, and then push the lens into the mount.
- 4 Secure the lens by turning the mount lever counterclockwise while holding the lens.

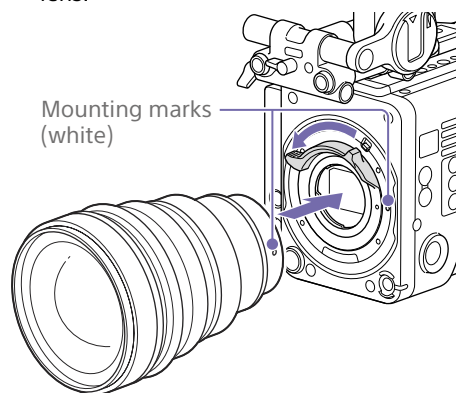

## To remove the lens

- 1 Push the lock switch up, and turn the mount lever clockwise to release the lock.
- 2 Pull the lens forward.

### [Note]

If another lens will not be attached soon, carefully align the concave part of the mount cover, then secure the mount cover by turning the mount lever counterclockwise.

### [Note]

When an E-mount lens is connected, operation using a 12-pin lens connector is not guaranteed.

# Attaching a Viewfinder

## Available viewfinders for the unit

DVF-EL200: OLED color viewfinder

Viewfinders are available separately. This section describes attachment of the DVF-EL200 as an example.

For details about attaching each viewfinder, refer to the operating instructions of the viewfinder.

### [CAUTION]

Do not leave the unit with the eyepiece of the viewfinder facing the sun. Direct sunlight can enter through the eyepiece, be focused in the viewfinder, and cause fire.

### [Notes]

Attach/remove the viewfinder while the unit is turned off.

## Attaching a Viewfinder

- 1 Align the viewfinder shoe with the groove of the viewfinder mount on the VF attachment, and attach the viewfinder.
- 2 Turn the viewfinder lock lever in the LOCK direction to secure it in position.

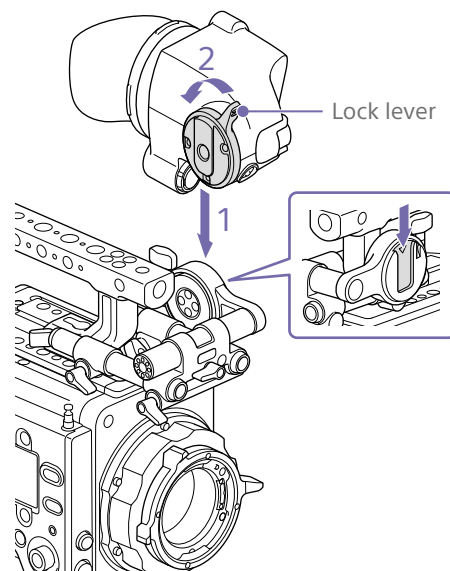

- 3 Connect the viewfinder and unit using the VF connection cable.
 

Viewfinder side:  
Position the connector with the mark (red) at the top, and fully insert the connector.

Camera side:  
Align the concave part of the VF connector with the connector mark (red), and fully insert the connector.

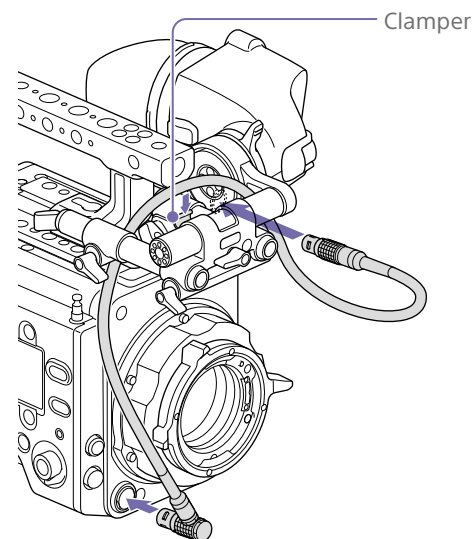

### [Note]

Secure the cable in the clasper as required.

## To remove the viewfinder

- 1 Disconnect the VF connection cable from the viewfinder and unit.
- 2 Turn the lock lever in the direction opposite to LOCK, then remove the viewfinder from the VF attachment.

## Adjusting the Viewfinder Position

### To adjust the front/rear position

- 1 Loosen one or both of the front/rear rod lock levers of the VF attachment.
- 2 Slide the VF attachment forward/rearward to adjust the viewfinder position.

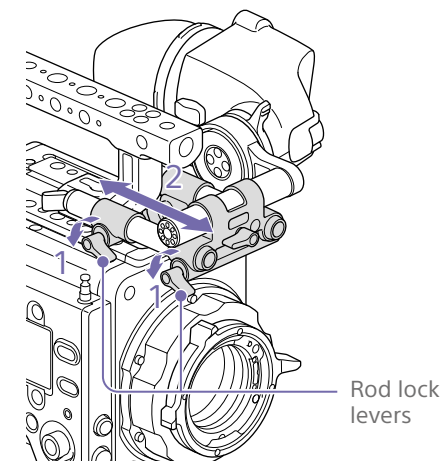

- 3 Tighten the rod lock levers.

### [Note]

If a rod lock lever is difficult to turn, pull the lever out, turn it to a position where it is easier to operate, and then push the lever back in.



## To adjust the left/right position and height (angle)

- 1 Loosen the rod lock lever at the front of the VF attachment.
- 2 Slide the VF attachment rod left/right and turn the rod up/down to adjust the viewfinder position.

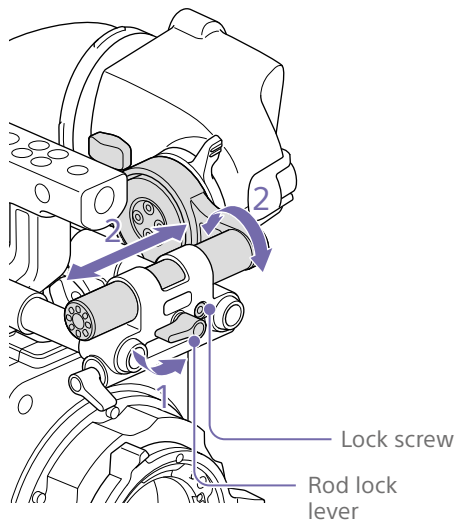

- 2 Turn the viewfinder up/down to adjust the angle.

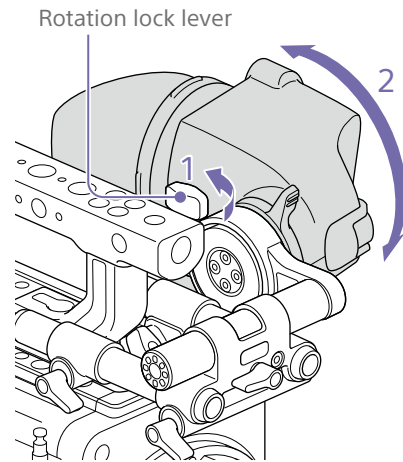

- 3 Tighten the rotation lock lever.

- 3 Tighten the rod lock lever.

### [Note]

When the rod lock lever is loosened, adjust the lock screw using a hex wrench (3 mm) to prevent the viewfinder from falling down.

## To adjust the viewfinder angle

You can adjust the angle of the viewfinder while shooting.

- 1 Loosen the rotation lock lever on the viewfinder mount.

# Handling AXS Memory Cards

This unit records audio and video on AXS memory cards (optional) loaded in the card slots.

## About AXS Memory Cards

Use the following Sony AXS memory cards with this unit.

### S24

AXS-A1TS24 (1 TB/2.4 Gbps)  
AXS-A256S24 (256 GB/2.4 Gbps)  
AXS-A512S24 (512 GB/2.4 Gbps)

### S48

AXS-A1TS48 (1 TB/4.8 Gbps)  
AXS-A512S48 (512 GB/4.8 Gbps)

### S66

AXS-A1TS66 (1 TB/6.6 Gbps)

## Inserting an AXS Memory Card

- 1 Open the cover of the card slot block (page 10).
- 2 Insert the AXS memory card into the slot with the label facing to the right. The ACCESS lamp (page 9) lights in red then changes to green once the memory card is ready for use.
- 3 Close the cover.

## ACCESS lamp status

Card slots A and B each have an ACCESS lamp that indicate the slot status.

Lamp	Slot status
Lights in red	Accessing the AXS memory card (writing/reading data)
Lights in green	Standby (ready for recording or playback using the AXS memory card)
Off	<ul style="list-style-type: none"> <li>• No AXS memory card is loaded.</li> <li>• The loaded card is invalid.</li> <li>• An AXS memory card is loaded, but the other slot is selected.</li> </ul>

## Removing an AXS Memory Card

- 1 Open the cover of the card slot block.
- 2 Pull out the AXS memory card.

### [Note]

Data integrity is not guaranteed if the power is turned off or a memory card is removed while it is being accessed. Data on the card may be destroyed. Be sure that its ACCESS lamp is lit in green or off when you turn off the power or remove a memory card.

## Switching Between AXS Memory Cards

When AXS memory cards are loaded in both slot A and slot B, you can press the SLOT SELECT button (page 9) to select the memory card to use. If a card becomes full, recording continues after automatically switching to the second card.

### [Note]

The SLOT SELECT button is disabled while recording/playback is in progress. The memory cards are not switched even if you press the button.

## Formatting (Initializing) an AXS Memory Card

When an unformatted AXS memory card or an AXS memory card formatted in another specification is loaded, a message notifying you that the media has a different file system appears. In this case, format the memory card using the following procedure.

- 1 Select TC/Media category > Format Media in the menu.
- 2 Select AXS Slot A (slot A) or AXS Slot B (slot B), then press the MENU dial. A confirmation screen prompting whether to format the card appears.
- 3 Press and hold ITEM key 1 and ITEM key 3 for 3 seconds to execute formatting. Formatting starts, a message is displayed during execution, and the ACCESS lamp lights in red. When formatting ends, a completion message appears. Press the MENU dial to dismiss the message.

## If formatting fails

A write-protected AXS memory card or memory card that cannot be used with this unit will not be formatted. A warning message is displayed. Replace the card with an appropriate AXS memory card, according to the instructions in the message.

### [Note]

All the data, including recorded pictures and setup files, are erased when a memory card is formatted.

## Checking the Remaining Recording Time

While shooting (recording or standby), you can check the remaining capacity on the AXS memory cards loaded in each slot using the recording media remaining capacity indicator on the Home screen of the sub display (page 36) or the viewfinder/monitor screen (page 14).

The available time for recording with the current video format (recording bit rate) is calculated according to the remaining space on each card and displayed in time units of minutes.

### [Note]

A  (protect) icon appears if a memory card is write-protected.

## Exchanging an AXS memory card

- If the total remaining time on the inserted memory cards during recording becomes less than the time set using Technical > Alerts & Tally > Media Near Full Alarm (page 89) in the full menu, the remaining media capacity indicator flashes, the REC lamp flashes, and a beep sound is emitted to warn you. Replace the cards with those that have sufficient space.
- If you continue recording, the message “Media Full” appears, and recording stops when the total remaining recording time falls to 0.

### [Notes]

- The maximum number of clips that can be recorded on a single AXS memory card is given below.  
S24/S48: Approximately 600  
S66: Approximately 430 to 440
- The display of remaining recording time changes to “0” and the message “Media Full” appears when the clip limit is reached.

## Restoring an AXS Memory Card

If for any reason an error should occur in a memory card, the card must be restored before use.

If an AXS memory card that needs to be restored is loaded, a message prompting you to execute the restore operation is displayed on the sub display.

To start the restore process, select Run by turning the MENU dial, then press the MENU dial.

The restoration starts.

During execution, a message is displayed and the ACCESS lamp lights in red.

When restoration ends, a completion message appears. Press the MENU dial to dismiss the message.

## If restoration fails

- A write-protected AXS memory card or one on which an error occurred cannot be restored. For such a card, a warning message is displayed. Release the write protection or replace the AXS card, according to the instructions in the message.
- An AXS memory card on which an error occurred may become usable again when reformatted.
- In some cases, some clips can be restored while others cannot. Playback of the restored clips becomes possible again.

### [Note]

For restoration of media recorded with this unit, be sure to use this unit.

Media recorded with a device other than this unit or with another unit of different version (even of the same model) may not be restored using this unit.



Recording Format	Imager Mode	Shooting frame rate and S24/S48/S66 AXS memory card support														
		24	25	30	48	50	60	66	72	75	88	90	96	100	110	120
4K ProRes 422 HQ	8.2K 17:9	S24/S48/S66	S24/S48/S66	S24/S48/S66	S24/S48/S66	S24/S48/S66	S24/S48/S66	-	-	-	-	-	-	-	-	-
	5.8K 6:5	S24/S48/S66	S24/S48/S66	S24/S48/S66	S24/S48/S66	-	-	-	-	-	-	-	-	-	-	-
	5.8K 17:9	S24/S48/S66	S24/S48/S66	S24/S48/S66	S24/S48/S66	S24/S48/S66	S24/S48/S66	S24/S48/S66	S24/S48/S66	S48/S66	S48/S66	-	-	-	-	-
QFHD ProRes 4444	7.6K 16:9	S24/S48/S66	S24/S48/S66	S24/S48/S66	S24/S48/S66	S24/S48/S66	S48/S66	-	-	-	-	-	-	-	-	-
	5.4K 16:9	S24/S48/S66	S24/S48/S66	S24/S48/S66	S24/S48/S66	S24/S48/S66	S48/S66	-	-	-	-	-	-	-	-	-
QFHD ProRes 422 HQ	7.6K 16:9	S24/S48/S66	S24/S48/S66	S24/S48/S66	S24/S48/S66	S24/S48/S66	S24/S48/S66	-	-	-	-	-	-	-	-	-
	5.4K 16:9	S24/S48/S66	S24/S48/S66	S24/S48/S66	S24/S48/S66	S24/S48/S66	S24/S48/S66	S24/S48/S66	S24/S48/S66	S24/S48/S66	-	-	-	-	-	-

1) When using S66 AXS memory cards, recording is supported by changing the recording format to X-OCN ST or LT. When using S48 AXS memory cards, recording is supported by changing the recording format to X-OCN LT.









Recording Format	Imager Mode	Shooting frame rate and S24/S48/S66 AXS memory card support														
		24	25	30	48	50	60	66	72	75	88	90	96	100	110	120
4K ProRes 422 HQ	6K 17:9	S24/S48/S66	S24/S48/S66	S24/S48/S66	S24/S48/S66	S24/S48/S66	S24/S48/S66	S24/S48/S66	S24/S48/S66	S48/S66	-	-	-	-	-	-
	6K 2.39:1	S24/S48/S66	S24/S48/S66	S24/S48/S66	S24/S48/S66	S24/S48/S66	S24/S48/S66	S24/S48/S66	S24/S48/S66	S48/S66	S48/S66	-	-	-	-	-
	4K 6:5	S24/S48/S66	S24/S48/S66	S24/S48/S66	S24/S48/S66	S24/S48/S66	S24/S48/S66	S24/S48/S66	S24/S48/S66	S48/S66	-	-	-	-	-	-
	4K 17:9 Surround View	S24/S48/S66	S24/S48/S66	S24/S48/S66	S24/S48/S66	-	-	-	-	-	-	-	-	-	-	-
	4K 17:9	S24/S48/S66	S24/S48/S66	S24/S48/S66	S24/S48/S66	S24/S48/S66	S24/S48/S66	S24/S48/S66	S24/S48/S66	S48/S66	S48/S66	S48/S66	S48/S66	-	-	-
	4K 2.39:1	S24/S48/S66	S24/S48/S66	S24/S48/S66	S24/S48/S66	S24/S48/S66	S24/S48/S66	S24/S48/S66	S24/S48/S66	S48/S66	S48/S66	S48/S66	S48/S66	-	-	-
QFHD ProRes 4444	5.7K 16:9	S24/S48/S66	S24/S48/S66	S24/S48/S66	S24/S48/S66	S24/S48/S66	S48/S66	-	-	-	-	-	-	-	-	
	3.8K 16:9 Surround View	S24/S48/S66	S24/S48/S66	S24/S48/S66	S24/S48/S66	-	-	-	-	-	-	-	-	-	-	
	3.8K 16:9	S24/S48/S66	S24/S48/S66	S24/S48/S66	S24/S48/S66	S24/S48/S66	S48/S66	-	-	-	-	-	-	-	-	
QFHD ProRes 422 HQ	5.7K 16:9	S24/S48/S66	S24/S48/S66	S24/S48/S66	S24/S48/S66	S24/S48/S66	S24/S48/S66	S24/S48/S66	S24/S48/S66	-	-	-	-	-	-	
	3.8K 16:9 Surround View	S24/S48/S66	S24/S48/S66	S24/S48/S66	S24/S48/S66	-	-	-	-	-	-	-	-	-	-	
	3.8K 16:9	S24/S48/S66	S24/S48/S66	S24/S48/S66	S24/S48/S66	S24/S48/S66	S24/S48/S66	S24/S48/S66	S24/S48/S66	S24/S48/S66	S48/S66	S48/S66	-	-	-	

# Handling SD Cards for Saving Configuration Data

You can store the configuration file of the camera on an SD card (optional). The stored file can be loaded from the SD card.

## Supported SD Cards

SDXC memory cards\* (File System: exFAT, Speed Class: 4 to 10, non-UHS, Capacity: 64 GB to 2 TB)

SDHC memory cards\* (File System: FAT32, Speed Class: 4 to 10, non-UHS, Capacity: 4 GB to 32 GB)

SD memory cards\* (File System: FAT16, Capacity: up to 2 GB)

\* Referred to as "SD cards" in this manual.

## Inserting an SD Card

Insert an SD card into the SD card slot (page 13).

The ACCESS lamp (page 11) lights in red then changes to green once the memory card is ready for use.

## ACCESS lamp status

Lamp	Slot status
Lights in red	Accessing the SD card (writing/reading data)
Off	<ul style="list-style-type: none"> <li>No SD card is loaded.</li> <li>The loaded card is invalid.</li> </ul>

## Removing an SD Card

Press the SD card in slightly, then remove the card.

### [Notes]

- Data integrity is not guaranteed if the power is turned off or a memory card is removed while it is being accessed. Data on the card may be destroyed. Be sure that its ACCESS lamp is lit in green or off when you turn off the power or remove a memory card.
- Make sure that the card does not pop out when inserting or removing it.

## Formatting (Initializing) an SD Card

SD cards must be formatted the first time they are used in the unit.

SD cards for use in the unit should be formatted using the format function of the unit. It is also necessary to format an SD memory card if a caution message is displayed when the card is loaded.

If an SD card that was formatted in an unsupported format is loaded in the unit, a file system mismatch message is displayed.

**1** Select TC/Media category > Format Media > SD Card in the menu, then press the MENU dial.

A confirmation screen prompting whether to format the card appears.

**2** Press and hold ITEM key 1 and ITEM key 3 for 3 seconds to execute formatting.

Formatting starts, a message is displayed during execution, and the ACCESS lamp lights in red.

When formatting ends, a completion message appears. Press the MENU dial to dismiss the message.

### [Note]

All data is erased when an SD card is formatted, and the data cannot be restored.

## To use media formatted with this unit in the slots of other devices

Make a backup of the media, then format it using the other device.

# Sub Display

The sub display displays the Home screen, clip list screen, playback screen, menu screen, full menu screen, and user functions screen. You can switch between the screens on the sub display using the buttons on the Assistant side of the unit.

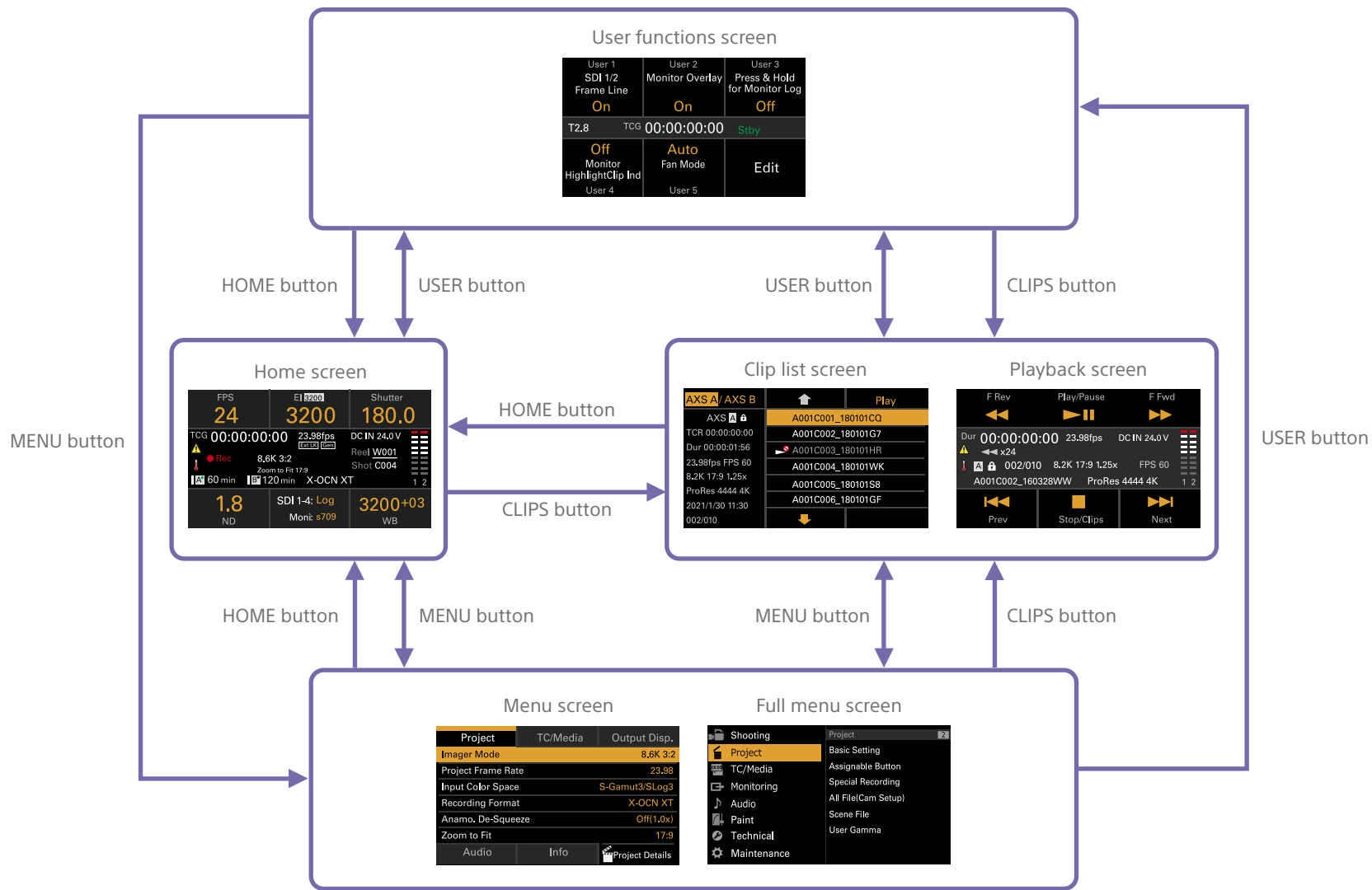

## Home Screen

Press the HOME button on the Assistant side to display the Home screen. You can check the status of the unit and set basic settings for the unit on the Home screen.

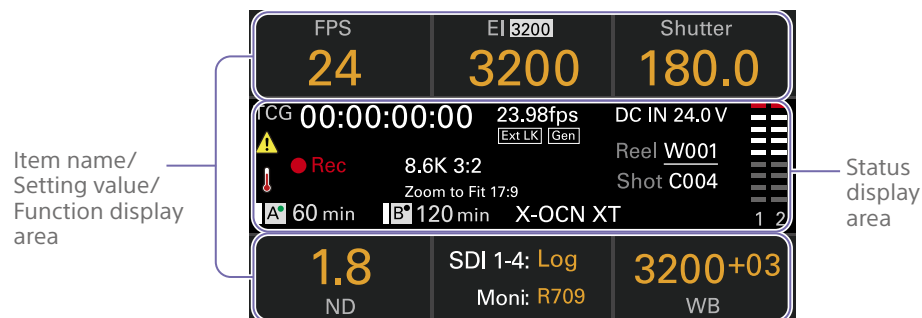

## Item name/Setting value/Function display area

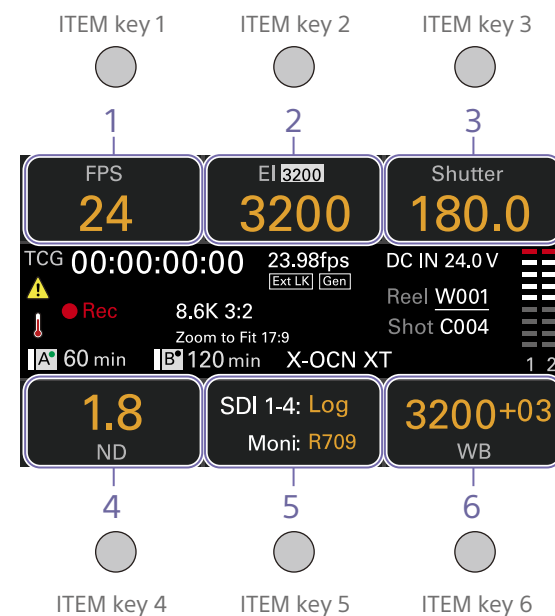

### [Note]

The areas labeled 1 to 6 correspond to ITEM keys 1 to 6 (page 48). Press an ITEM key to select the corresponding item. The ITEM keys for functions displayed in orange text color are enabled.

### 1. FPS

Displays and sets the video frame rate.

### 2. Exposure Index/Gain

Displays and sets the exposure index (EI) or the gain set by an RM-B170 or other remote control unit (top icon displays the base sensitivity).

### [Note]

The gain value is displayed only when Technical > Special Configuration > RM/RCP Paint Control (page 91) is set to On in the full menu.

### 3. Shutter

Displays and sets the shutter speed/shutter angle of the electronic shutter.

### 4. ND Filter

Displays and sets the ND filter position.

### 5. LUT

Displays and sets the monitor LUT.

### 6. WB (White Balance)

Displays and sets the white balance.

## Status display area

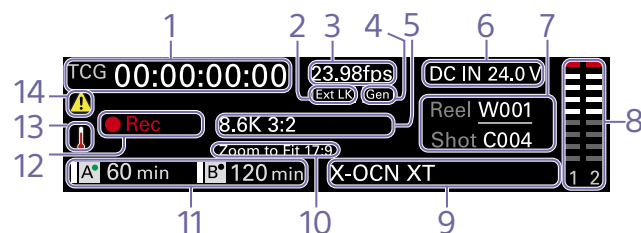

### 1. Time data display

Displays the duration or timecode, depending on the TC/Media category > TC Display setting in the menu (page 56).

Displays the type of data currently shown in the time data display, as follows.

TCG: Recorded timecode

TCR: Playback timecode

Dur: Duration

### 2. Ext-LK icon

Displayed when the internal timecode generator is locked to an external signal input to the TC IN (timecode input) connector.

### 3. Frame rate indicator

Displays the value of the Project category > Project Frame Rate setting in the menu (page 54).

### 4. Genlock icon

Displays locked status when genlocked.

### 5. Imager mode indicator

Displays the Project category > Imager Mode setting in the menu, and de-squeeze information.

### 6. Power supply voltage/Remaining battery capacity indicator

Displays the power supply voltage or remaining battery capacity.

### 7. Clip name display

Displays "Reel: Camera ID + Reel Number" and "ShotNumber".

### 8. Audio level meters

Displays the audio recording or playback levels. The numbers 1 and 2 indicate channels 1 and 2.

### 9. Recording format (codec) indicator

Displays the format of the recording on an AXS memory card (page 59).

### 10. Zoom to Fit setting indicator

Displays the Project > Basic Setting > Zoom to Fit (page 73) setting in the full menu.

#### [Note]

Not displayed when Zoom to Fit is set to Off or not available.

### 11. Remaining media capacity indicator

Displays the active media icon, media type, slot type (A/B), and remaining recording time (when recording in the current recording format).

It also displays the clip name during playback.

### 12. Recording status indicator

Displays the following recording operation states of the unit.

Display	Description
Stby	Recording standby
●Rec	Recording
●Cache	Picture cache recording standby
CALL	CALL command incoming

### 13. Thermometer icon

Displayed when a high temperature warning message is issued.

The description is displayed in the Info category in the menu.

### 14. Warning icon

Displayed when other than a high temperature warning message is issued.

The description is displayed in the Info category in the menu.

# Operations on the Home Screen of the Sub Display

## Basic Operation

- 1 Press the HOME button.  
The Home screen appears.

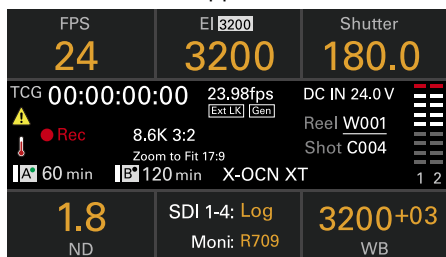

- 2 Select the item to set using the ITEM keys 1 to 6.

The setting value for items that can be changed are displayed in orange. The following diagram shows an example when ITEM key 3 is pressed.

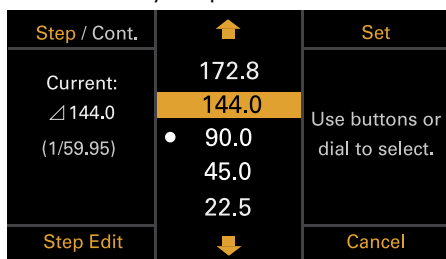

- 3 Move the cursor to the item or setting value to select using the **↑** button (ITEM key 2), **↓** button (ITEM key 5), or MENU dial.
- 4 Press the MENU dial or Set button (ITEM key 3) to apply the setting.

## Changing the brightness of the sub display

You can change the brightness of the sub display using Technical > Panel Control > Brightness level (page 89) in the full menu. On the Home screen, you can also press and hold the BACK button and turn the MENU dial clockwise to change the brightness of the sub display in the sequence Minimum → Low → Mid → High with the current setting as the base point.

You can also press and hold the BACK button and turn the MENU dial counterclockwise to change the brightness of the sub display in the sequence High → Mid → Low → Minimum with the current setting as the base point.

### [Note]

The display brightness setting is common to both the sub display and the mini display, and is reflected on both displays simultaneously.

## Display and operation when RM/RCP Paint Control is enabled

- The gain value is displayed in the EI control area when Technical > Special Configuration > RM/RCP Paint Control (page 91) is set to On in the full menu. In this mode, the EI value cannot be changed, but the gain value can be changed (page 39). However, the Base ISO setting can be switched.
- The following control areas are grayed out and cannot be operated when an RM-B170 or other remote control unit is connected and Technical > Special Configuration > RM/RCP Paint Control (page 91) is set to On in the full menu. Set these using the remote control unit (page 115).
  - Shutter control area
  - WB control area
  - Gain control area

## Step Edit Operation

You can change the settings available for selection when "Step Edit" is displayed for ITEM key 4 in step 2 in the basic operation. You can add and delete settings on the settings edit screen.

- 1 On the settings selection screen, move the cursor to the setting you want to change or delete, and press the Step Edit button (ITEM key 4).  
The settings edit screen appears.

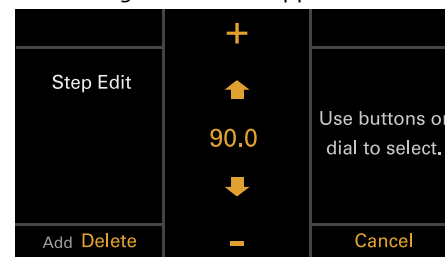

- 2 To delete a setting, press the Delete button (ITEM key 4).

### [Note]

The selected setting can be deleted if the "Delete" character string is displayed in orange.

- 3 Use the **↑** button (ITEM key 2), **↓** button (ITEM key 5), or MENU dial to change the setting.

- 4 When finished, press the Add button (ITEM key 4).  
The setting is added and the display returns to the setting selection screen.

### [Note]

A setting can be added if the "Add" character string is displayed in orange.

## When setting White Balance

On the White Balance settings edit screen, you can press the Coarse/Fine button (ITEM key 1) to change the 1-step increment variation to coarse or fine. You can also press the Temp/Tint button (ITEM key 3) to switch the value between color temperature (Temp) and color tone (Tint).

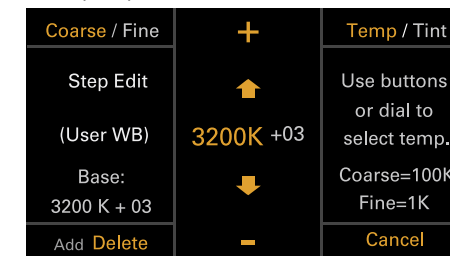

## FPS Operation

Press ITEM key 1 on the Home screen to display the FPS operation screen. You can press the Variable/Fixed button (ITEM key 4) to switch between "Fixed" for constant speed shooting and "Variable (Select FPS)" for variable speed shooting.

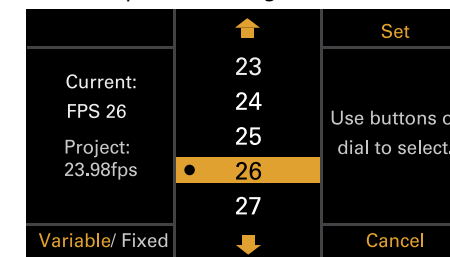

### [Note]

Audio is not recorded in "Select FPS" mode.

## EI Operation/Gain Operation

You can change the EI value. The gain value is displayed instead of the EI value when Technical > Special Configuration > RM/RCP Paint Control (page 91) is set to On in the full menu. You can change the gain value when an RM-B170 or other remote control unit is not connected.

### Changing the EI value or gain value

#### [Note]

This section shows the display for when changing the EI value as an example.

You can change the EI value or gain value using ITEM key 2 on the Home screen.

- 1 Press ITEM key 2 on the Home screen. The EI setup screen or Gain setup screen appears.

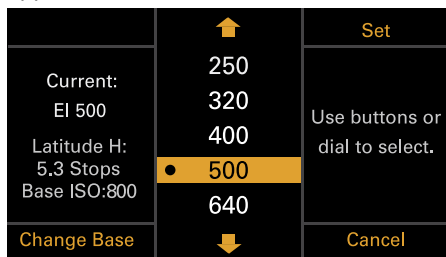

- 2 Use the **↑** button (ITEM key 2), **↓** button (ITEM key 5), or MENU dial to change the setting.

- 3 Press the MENU dial or Set button (ITEM key 3) to apply the setting.

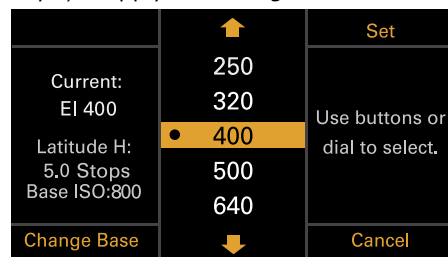

### Switching the Base ISO

You can switch the Base ISO by pressing ITEM key 4 on the EI setup screen or Gain setup screen.

- 1 Press ITEM key 4 on the EI setup screen or Gain setup screen. The Base ISO switching screen appears.
- 2 Press the two Change buttons (ITEM key 1 and ITEM key 3) simultaneously.

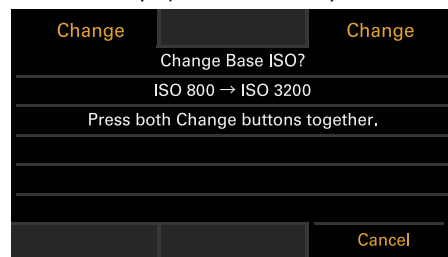

The Base ISO is changed (page 46).

## AWB Operation

Press ITEM key 6 on the Home screen to display the white balance operation screen. Press the Auto White Bal. button (ITEM key 1) to execute white balance. After execution, press the Add button (ITEM key 4) to add the setting to a step. You can also press the Temp/Tint button (ITEM key 3) to switch the value between color temperature (Temp) and color tone (Tint) to make fine adjustments to the value before adding a value to a step.

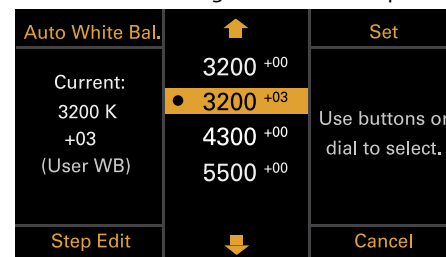

#### [Note]

During AWB operation, shoot a white chart under uniform lighting conditions.

## LUT Operation

### Setting a LUT

You can set a LUT for each output system using ITEM key 5 on the Home screen.

- 1 Press ITEM key 5 on the Home screen. The LUT selection screen appears.

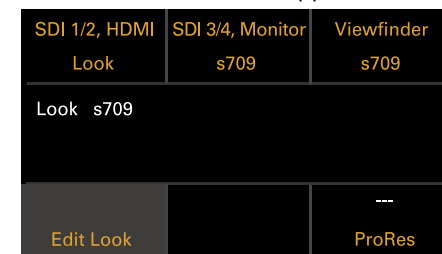

#### [Note]

User gamma information is displayed on the LUT selection screen when Project > Basic Setting > Input Color Space (page 72) is set to Rec.2020/User Gamma or Rec.709/User Gamma in the full menu.

- 2 Select the output to set using ITEM keys 1, 2, 3, and 6. The settings edit screen appears.
- 3 Use the **↑** button (ITEM key 2), **↓** button (ITEM key 5), or MENU dial to change the setting.
- 4 Press the MENU dial or Set button (ITEM key 3) to apply the setting.

## LUT selection screen display items

The items displayed will vary depending on the Output Format setting.

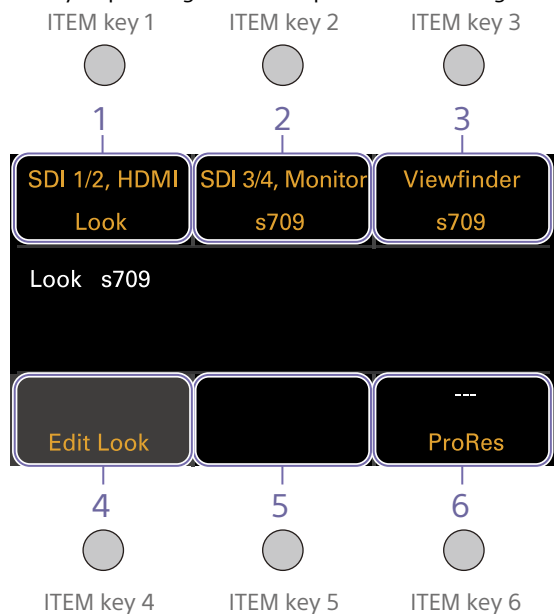

Output Format					Display indication				
SDI1/2	SDI3/4	Monitor	HDMI	VF	ITEM key 1	ITEM key 2	ITEM key 3	ITEM key 5	ITEM key 6
4K/QFHD 12G/6G	FHD	FHD	4K/ QFHD	FHD	SDI 1/2, HDMI	SDI 3/4, Monitor	Viewfinder	Blank	ProRes <sup>1)</sup>
			FHD		SDI 1/2	SDI 3/4, Moni, HDMI	Viewfinder	Blank	ProRes <sup>1)</sup>
4K/QFHD Square Quad			FHD		SDI 1/2/3/4	Blank	Viewfinder	Monitor, HDMI	ProRes <sup>1)</sup>
4K/QFHD 2SI Quad			4K/ QFHD		SDI 1-4, HDMI	Blank	Viewfinder	Monitor	ProRes <sup>1)</sup>
			FHD		SDI 1/2/3/4	Blank	Viewfinder	Monitor, HDMI	ProRes <sup>1)</sup>

Output Format					Display indication				
SDI1/2	SDI3/4	Monitor	HDMI	VF	ITEM key 1	ITEM key 2	ITEM key 3	ITEM key 5	ITEM key 6
4K/QFHD Square Dual	FHD	FHD	FHD	FHD	SDI 1/2	SDI 3/4, Moni, HDMI	Viewfinder	Blank	ProRes <sup>1)</sup>
4K/QFHD 2SI Dual	FHD		4K/ QFHD		SDI 1/2, HDMI	SDI 3/4, Monitor	Viewfinder	Blank	ProRes <sup>1)</sup>
			FHD		SDI 1/2	SDI 3/4, Moni, HDMI	Viewfinder	Blank	ProRes <sup>1)</sup>
2K/FHD	FHD		FHD		SDI 1/2	SDI 3/4	Viewfinder	Monitor, HDMI	ProRes <sup>1)</sup>
FHD	FHD	-	SD		SDI 1/2	SDI 3/4	Viewfinder	Monitor	HDMI

1) Blank when Project > Basic Setting > Recording Format is set to X-OCN format in the full menu

## Changing Preset Look

You can set a LUT when Look is selected on the LUT selection screen using the Edit Look button (ITEM key 4) on the LUT selection screen.

- 1 Press the Edit Look button (ITEM key 4) on the LUT selection screen. The Look selection screen appears.

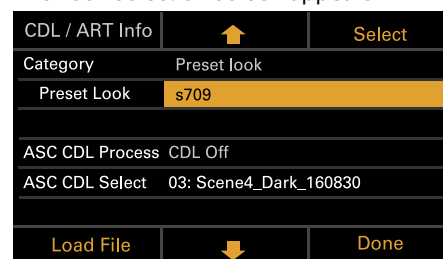

- 2 Select Category > Preset Look, use the ↓ button (ITEM key 5) or MENU dial to move the cursor to Preset Look, and press the Select button (ITEM key 3). The items that can be selected are displayed.

- 3 Use the ↑ button (ITEM key 2), ↓ button (ITEM key 5), or MENU dial to change the setting.

- 4 Press the MENU dial or Set button (ITEM key 3) to apply the setting.

## Changing the LUT category

You can change the target category for LUT operations to User 3D LUT, ART, ACES, or Preset Look (page 66).

- 1 Press the Edit Look button (ITEM key 4) on the LUT selection screen. The Look selection screen appears.
- 2 Move the cursor to Category, and press the MENU dial or the Select button (ITEM key 3).
- 3 Use the ↑ button (ITEM key 2), ↓ button (ITEM key 5), or MENU dial to select a category (User 3D LUT, ART, ACES, or Preset Look).

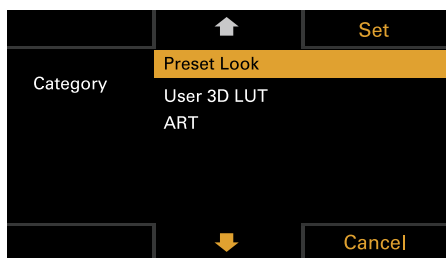

**[Note]**

The selection options change as follows depending on the Project > Basic Setting > Input Color Space (page 72) setting in the full menu.

- S-Gamut3.Cine/SLog3 or S-Gamut3/SLog3: Preset Look / User 3D LUT / ART
- ACEScct: Preset Look / ACEScct with User 3D / ACESproxy with User 3D / ACES with ART

- 4 Press the MENU dial or Set button (ITEM key 3) to apply the setting.

### Loading a User 3D LUT file

You can load a User 3D LUT file stored on an SD card into the unit.

You can also load a User 3D LUT file into the unit via a network (page 104).

**[Note]**

Save the User 3D LUT file in the following directory on the SD card (page 110).

PRIVATE\SONY\PRO\LUT\

- 1 Insert the SD card into the SD card slot (page 13).
- 2 Press the Edit Look button (ITEM key 4) on the LUT selection screen. The Look selection screen appears.
- 3 Press the Load File button (ITEM key 4). A file type selection screen appears.

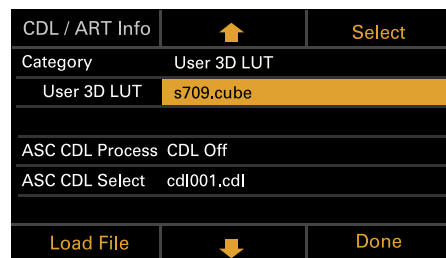

- 4 Use the ↑ button (ITEM key 2), ↓ button (ITEM key 5), or MENU dial to select Load User 3D LUT File.

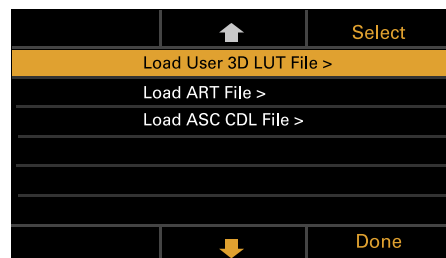

- 5 Press the MENU dial or the Select button (ITEM key 3). The load destination numbers (01 to 16) are displayed. A file name is displayed for loaded numbers.

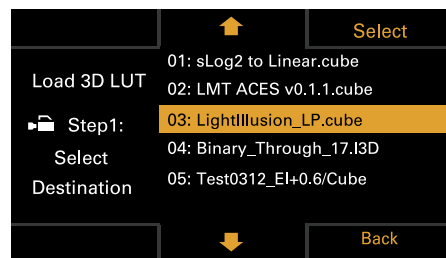

- 6 Use the ↑ button (ITEM key 2), ↓ button (ITEM key 5), or MENU dial to select a load destination number.

- 7 Press the MENU dial or the Select button (ITEM key 3). The file name of the User 3D LUT file stored on the SD card is displayed.

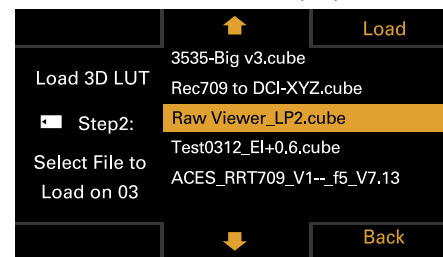

- 8 Use the ↑ button (ITEM key 2), ↓ button (ITEM key 5), or MENU dial to select a file.

- 9 Press the MENU dial or the Load button (ITEM key 3). When the file is loaded successfully, "Successfully loaded" is displayed.

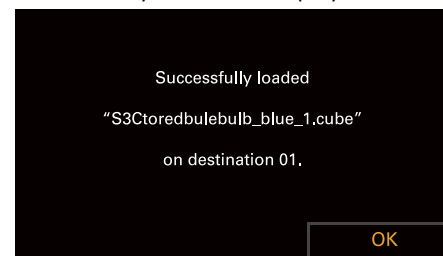

- 10 Press the OK button (ITEM key 6).

### Loading an ART file

You can load an ART file stored on an SD card into the unit.

You can also load an ART file into the unit via a network (page 105).

**[Note]**

Save the ART file in the following directory on the SD card (page 110).

MPC-3628:  
PRIVATE\SONY\PRO\CAMERA\MPC3628

MPC-3626:  
PRIVATE\SONY\PRO\CAMERA\MPC3626

- 1 Insert the SD card into the SD card slot (page 13).
- 2 Press the Edit Look button (ITEM key 4) on the LUT selection screen. The Look selection screen appears.
- 3 Press the Load File button (ITEM key 4). A file type selection screen appears.

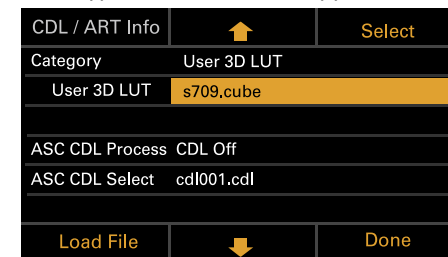

- 4 Use the ↑ button (ITEM key 2), ↓ button (ITEM key 5), or MENU dial to select Load ART File.

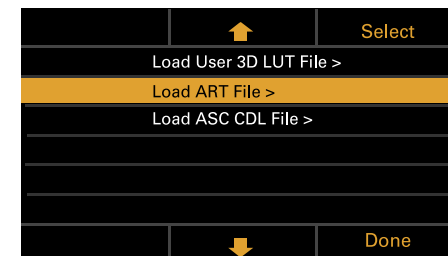

- 5 Press the MENU dial or the Select button (ITEM key 3). The load destination numbers (01 to 16) are displayed. A file name is displayed for loaded numbers.

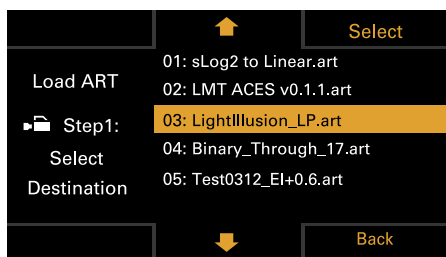

- 6 Use the **↑** button (ITEM key 2), **↓** button (ITEM key 5), or MENU dial to select a load destination number.

- 7 Press the MENU dial or the Select button (ITEM key 3). The file name of the ART file stored on the SD card is displayed.

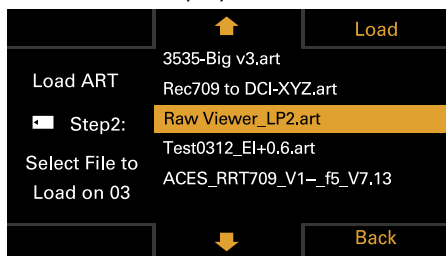

- 8 Use the **↑** button (ITEM key 2), **↓** button (ITEM key 5), or MENU dial to select a file.

- 9 Press the MENU dial or the Load button (ITEM key 3). When the file is loaded successfully, "Successfully loaded" is displayed.

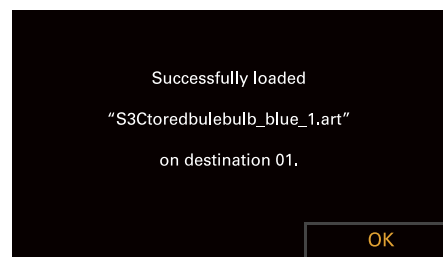

- 10 Press the OK button (ITEM key 6).

### Loading an ASC CDL file

You can load an ASC CDL file stored on an SD card into the unit.

You can also load an ASC CDL file into the unit via a network (page 105).

#### [Note]

Save the ASC CDL file in the following directory on the SD card (page 110).  
PRIVATE\SONY\PRO\CDL\

- 1 Insert the SD card into the SD card slot (page 13).
- 2 Press the Edit Look button (ITEM key 4) on the LUT selection screen. The Look selection screen appears.
- 3 Press the Load File button (ITEM key 4). A file type selection screen appears.

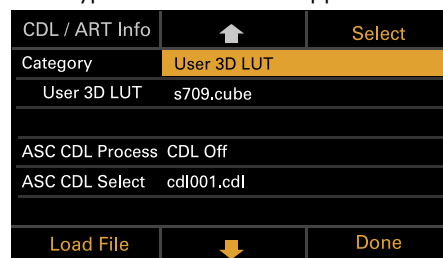

- 4 Select Load ASC CDL File, and press the MENU dial or the Select button (ITEM key 3).

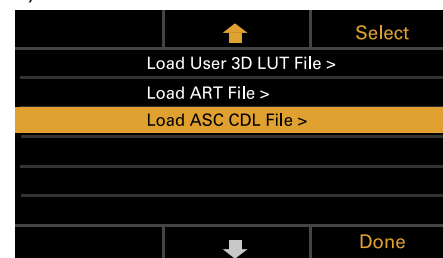

The file name of the ASC CDL file stored on the SD card is displayed.

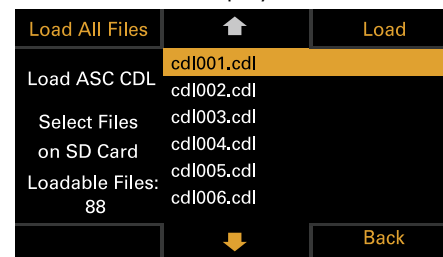

- 5 Use the **↑** button (ITEM key 2), **↓** button (ITEM key 5), or MENU dial to select a file.
- 6 Press the MENU dial or the Load button (ITEM key 3). You can press the Load All Files button (ITEM key 1) to load all files. When the file is loaded successfully, "Successfully loaded" is displayed.
- 7 Press the OK button (ITEM key 6).

### Changing the User 3D LUT File

You can change the currently selected User 3D LUT file.

- 1 Press the Edit Look button (ITEM key 4) on the LUT selection screen. The Look selection screen appears.

- 2 Move the cursor to Category, and press the MENU dial or the Select button (ITEM key 3) to select User 3D LUT.

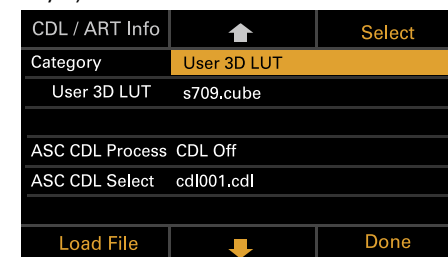

- 3 Move the cursor to User 3D LUT, and press the MENU dial or the Select button (ITEM key 3).

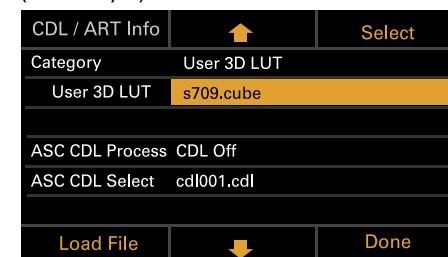

- 4 Use the **↑** button (ITEM key 2), **↓** button (ITEM key 5), or MENU dial to change the User 3D LUT file.



- 5 Press the MENU dial or Set button (ITEM key 3) to apply the setting.

## Changing the ART File

You can change the currently selected ART file.

- 1 Press the Edit Look button (ITEM key 4) on the LUT selection screen. The Look selection screen appears.

- 2 Move the cursor to Category, and press the MENU dial or the Select button (ITEM key 3) to select ART.

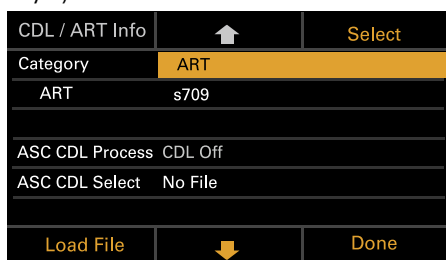

- 3 Move the cursor to ART, and press the MENU dial or the Select button (ITEM key 3).

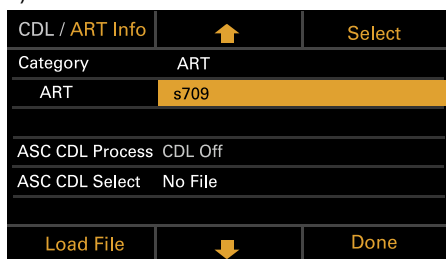

- 4 Use the ↑ button (ITEM key 2), ↓ button (ITEM key 5), or MENU dial to change the ART file.

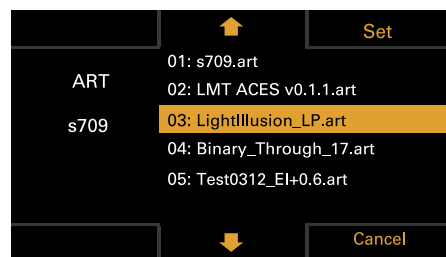

- 5 Press the MENU dial or Set button (ITEM key 3) to apply the setting.

## Displaying ART file information

You can display information for the currently selected ART file.

- 1 Press the Edit Look button (ITEM key 4) on the LUT selection screen. The Look selection screen appears.

- 2 Move the cursor to ART, and press the CDL / ART Info button (ITEM key 1).

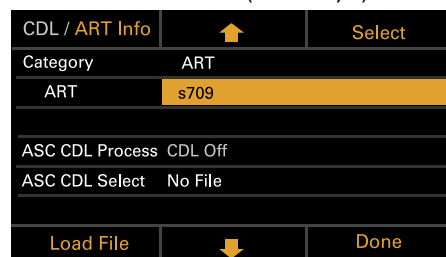

The ART file information is displayed.

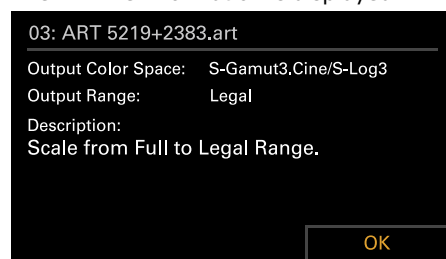

## Changing the ASC CDL File

You can change the currently selected ASC CDL file.

- 1 Press the Edit Look button (ITEM key 4) on the LUT selection screen. The Look selection screen appears.

- 2 Select ASC CDL Select, and press the MENU dial or the Select button (ITEM key 3).

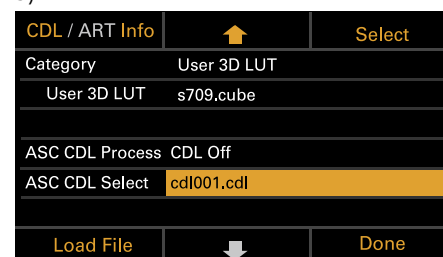

- 3 Use the ↑ button (ITEM key 2), ↓ button (ITEM key 5), or MENU dial to change the ASC CDL file.

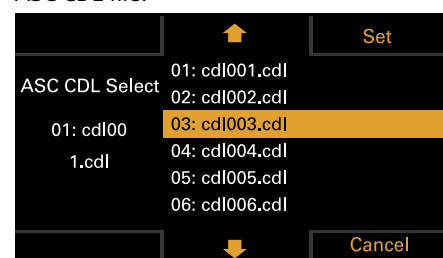

[Note]

Files that cannot be applied on the unit are grayed out.

- 4 Press the MENU dial or Set button (ITEM key 3) to apply the setting.

## Specifying the ASC CDL file processing order

You can specify the ASC CDL processing order using ASC CDL Process on the Look selection screen.

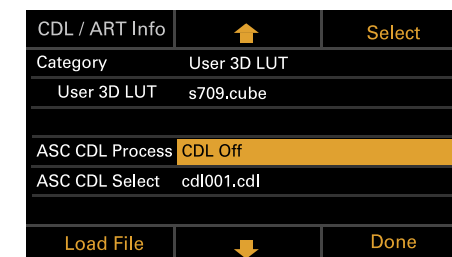

## Displaying ASC CDL file information

You can display information for the currently selected ASC CDL file.

- 1 Press the Edit Look button (ITEM key 4) on the LUT selection screen. The Look selection screen appears.

- 2 Move the cursor to ASC CDL Select, and press the CDL / ART Info button (ITEM key 1). The ASC CDL file information screen appears.

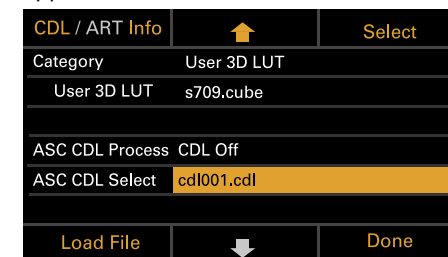

You can change the Saturation setting on the ASC CDL file information screen.

## Changing Saturation

- 1 Press the Edit button (ITEM key 4) on the ASC CDL file information screen. The Saturation edit screen appears.

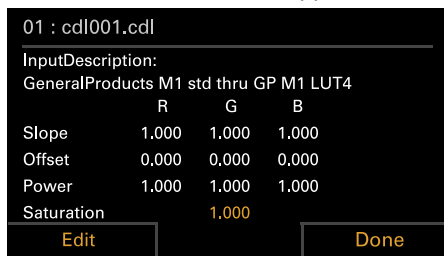

- 2 Move the cursor to the digit to change using the MENU dial, and press the MENU dial.

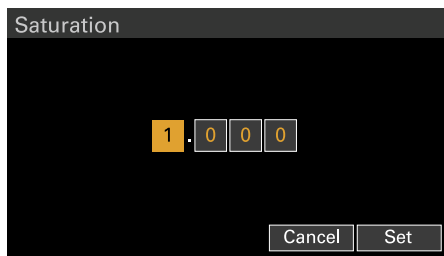

- 3 Use the MENU dial to change the setting, and press the MENU dial. The Saturation setting range is 0.000 to 3.999.

### [Note]

If you enter a value that exceeds the setting range and press the MENU dial, the previous value is restored.

- 4 Move the cursor to the Set button using the MENU dial, and press the MENU dial to apply the setting.

## About the ASC CDL file setting ranges

The ASC CDL file setting ranges are shown below. Files that exceed the ranges cannot be loaded.

Slope: 0.000 to 3.999

Offset: -1.000 to 1.000

Power: 0.400 to 4.000

Saturation: 0.000 to 3.999

## Home Screen Items on the Sub Display

The names of items and corresponding setting values are given below. Default values are shown underlined and in **bold** text.

Item	Description																
FPS	Sets the shooting frame rate. Variable/Fixed: Switch between variable speed and constant speed shooting. When "Fixed" is selected, the setting is determined by the Project category > Project Frame Rate (page 54) setting in the menu.																
	<table border="1"> <thead> <tr> <th>Project Frame Rate</th> <th>Display</th> </tr> </thead> <tbody> <tr> <td>23.98</td> <td>Fix 23.98</td> </tr> <tr> <td>24</td> <td>Fix 24.00</td> </tr> <tr> <td>25</td> <td>Fix 25.00</td> </tr> <tr> <td>29.97</td> <td>Fix 29.97</td> </tr> <tr> <td>47.95</td> <td>Fix 47.95</td> </tr> <tr> <td>50</td> <td>Fix 50.00</td> </tr> <tr> <td>59.94</td> <td>Fix 59.94</td> </tr> </tbody> </table>	Project Frame Rate	Display	23.98	Fix 23.98	24	Fix 24.00	25	Fix 25.00	29.97	Fix 29.97	47.95	Fix 47.95	50	Fix 50.00	59.94	Fix 59.94
Project Frame Rate	Display																
23.98	Fix 23.98																
24	Fix 24.00																
25	Fix 25.00																
29.97	Fix 29.97																
47.95	Fix 47.95																
50	Fix 50.00																
59.94	Fix 59.94																

Item	Description																												
	When "Variable" is selected, the settings change as follows depending on the Project category > Imager Mode (page 72) and Recording Format (page 72) settings in the menu.																												
	<b>X-OCN recording</b>																												
	MPC-3628																												
	<table border="1"> <thead> <tr> <th>Imager Mode</th> <th>Shooting frame rate</th> </tr> </thead> <tbody> <tr> <td>8.6K 3:2</td> <td>1 to 30 FPS</td> </tr> <tr> <td>8.2K 17:9</td> <td>1 to 60 FPS</td> </tr> <tr> <td>7.6K 16:9</td> <td></td> </tr> <tr> <td>5.8K 6:5</td> <td>1 to 48 FPS</td> </tr> <tr> <td>5.8K 17:9</td> <td>1 to 60, 66, 72, 75, 88, 90 FPS</td> </tr> <tr> <td>5.4K 16:9</td> <td></td> </tr> </tbody> </table>	Imager Mode	Shooting frame rate	8.6K 3:2	1 to 30 FPS	8.2K 17:9	1 to 60 FPS	7.6K 16:9		5.8K 6:5	1 to 48 FPS	5.8K 17:9	1 to 60, 66, 72, 75, 88, 90 FPS	5.4K 16:9															
Imager Mode	Shooting frame rate																												
8.6K 3:2	1 to 30 FPS																												
8.2K 17:9	1 to 60 FPS																												
7.6K 16:9																													
5.8K 6:5	1 to 48 FPS																												
5.8K 17:9	1 to 60, 66, 72, 75, 88, 90 FPS																												
5.4K 16:9																													
	MPC-3626																												
	<table border="1"> <thead> <tr> <th>Imager Mode</th> <th>Shooting frame rate</th> </tr> </thead> <tbody> <tr> <td>6K 3:2</td> <td>1 to 60 FPS</td> </tr> <tr> <td>6K 1.85:1</td> <td>1 to 60, 66, 72 FPS</td> </tr> <tr> <td>6K 17:9</td> <td></td> </tr> <tr> <td>5.7K 16:9</td> <td></td> </tr> <tr> <td>6K 2.39:1</td> <td>1 to 60, 66, 72, 75, 88, 90 FPS</td> </tr> <tr> <td>4K 6:5</td> <td>1 to 60, 66, 72 FPS</td> </tr> <tr> <td>4K 4:3</td> <td>1 to 60, 66, 72, 75 FPS</td> </tr> <tr> <td>4K 4:3 Surround View</td> <td>1 to 30 FPS</td> </tr> <tr> <td>4K 17:9</td> <td>1 to 60, 66, 72, 75, 88, 90, 96, 100, 110 FPS</td> </tr> <tr> <td>3.8K 16:9</td> <td></td> </tr> <tr> <td>4K 17:9 Surround View</td> <td>1 to 48 FPS</td> </tr> <tr> <td>3.8K 16:9 Surround View</td> <td></td> </tr> <tr> <td>4K 2.39:1</td> <td>1 to 60, 66, 72, 75, 88, 90, 96, 100, 110, 120 FPS</td> </tr> </tbody> </table>	Imager Mode	Shooting frame rate	6K 3:2	1 to 60 FPS	6K 1.85:1	1 to 60, 66, 72 FPS	6K 17:9		5.7K 16:9		6K 2.39:1	1 to 60, 66, 72, 75, 88, 90 FPS	4K 6:5	1 to 60, 66, 72 FPS	4K 4:3	1 to 60, 66, 72, 75 FPS	4K 4:3 Surround View	1 to 30 FPS	4K 17:9	1 to 60, 66, 72, 75, 88, 90, 96, 100, 110 FPS	3.8K 16:9		4K 17:9 Surround View	1 to 48 FPS	3.8K 16:9 Surround View		4K 2.39:1	1 to 60, 66, 72, 75, 88, 90, 96, 100, 110, 120 FPS
Imager Mode	Shooting frame rate																												
6K 3:2	1 to 60 FPS																												
6K 1.85:1	1 to 60, 66, 72 FPS																												
6K 17:9																													
5.7K 16:9																													
6K 2.39:1	1 to 60, 66, 72, 75, 88, 90 FPS																												
4K 6:5	1 to 60, 66, 72 FPS																												
4K 4:3	1 to 60, 66, 72, 75 FPS																												
4K 4:3 Surround View	1 to 30 FPS																												
4K 17:9	1 to 60, 66, 72, 75, 88, 90, 96, 100, 110 FPS																												
3.8K 16:9																													
4K 17:9 Surround View	1 to 48 FPS																												
3.8K 16:9 Surround View																													
4K 2.39:1	1 to 60, 66, 72, 75, 88, 90, 96, 100, 110, 120 FPS																												

Item	Description																																			
	<b>ProRes recording</b>																																			
	MPC-3628																																			
	<table border="1"> <thead> <tr> <th rowspan="2">Imager Mode</th> <th colspan="2">Shooting frame rate</th> </tr> <tr> <th colspan="2">ProRes 4K / QFHD</th> </tr> <tr> <td></td> <th>4444</th> <th>422 HQ</th> </tr> </thead> <tbody> <tr> <td>8.2K 17:9</td> <td>1 to 60 FPS</td> <td>1 to 60 FPS</td> </tr> <tr> <td>7.6K 16:9</td> <td></td> <td></td> </tr> <tr> <td>5.8K 6:5</td> <td>1 to 48 FPS</td> <td>1 to 48 FPS</td> </tr> <tr> <td>5.8K 17:9</td> <td>1 to 60 FPS</td> <td>1 to 60, 66, 72, 75 FPS</td> </tr> <tr> <td>5.4K 16:9</td> <td></td> <td></td> </tr> </tbody> </table>	Imager Mode	Shooting frame rate		ProRes 4K / QFHD			4444	422 HQ	8.2K 17:9	1 to 60 FPS	1 to 60 FPS	7.6K 16:9			5.8K 6:5	1 to 48 FPS	1 to 48 FPS	5.8K 17:9	1 to 60 FPS	1 to 60, 66, 72, 75 FPS	5.4K 16:9														
Imager Mode	Shooting frame rate																																			
	ProRes 4K / QFHD																																			
	4444	422 HQ																																		
8.2K 17:9	1 to 60 FPS	1 to 60 FPS																																		
7.6K 16:9																																				
5.8K 6:5	1 to 48 FPS	1 to 48 FPS																																		
5.8K 17:9	1 to 60 FPS	1 to 60, 66, 72, 75 FPS																																		
5.4K 16:9																																				
	MPC-3626																																			
	<table border="1"> <thead> <tr> <th rowspan="2">Imager Mode</th> <th colspan="2">Shooting frame rate</th> </tr> <tr> <th colspan="2">ProRes 4K / QFHD</th> </tr> <tr> <td></td> <th>4444</th> <th>422 HQ</th> </tr> </thead> <tbody> <tr> <td>6K 17:9</td> <td>1 to 60 FPS</td> <td>1 to 60, 66, 72 FPS</td> </tr> <tr> <td>5.7K 16:9</td> <td></td> <td></td> </tr> <tr> <td>6K 2.39:1</td> <td>1 to 60 FPS</td> <td>1 to 60, 66, 72, 75 FPS</td> </tr> <tr> <td>4K 6:5</td> <td>1 to 60 FPS</td> <td>1 to 60, 66, 72 FPS</td> </tr> <tr> <td>4K 17:9</td> <td>1 to 60 FPS</td> <td>1 to 60, 66, 72, 75, 88, 90 FPS</td> </tr> <tr> <td>3.8K 16:9</td> <td></td> <td></td> </tr> <tr> <td>4K 17:9 Surround View</td> <td>1 to 48 FPS</td> <td>1 to 48 FPS</td> </tr> <tr> <td>3.8K 16:9 Surround View</td> <td></td> <td></td> </tr> <tr> <td>4K 2.39:1</td> <td>1 to 60 FPS</td> <td>1 to 60, 66, 72, 75, 88, 90 FPS</td> </tr> </tbody> </table>	Imager Mode	Shooting frame rate		ProRes 4K / QFHD			4444	422 HQ	6K 17:9	1 to 60 FPS	1 to 60, 66, 72 FPS	5.7K 16:9			6K 2.39:1	1 to 60 FPS	1 to 60, 66, 72, 75 FPS	4K 6:5	1 to 60 FPS	1 to 60, 66, 72 FPS	4K 17:9	1 to 60 FPS	1 to 60, 66, 72, 75, 88, 90 FPS	3.8K 16:9			4K 17:9 Surround View	1 to 48 FPS	1 to 48 FPS	3.8K 16:9 Surround View			4K 2.39:1	1 to 60 FPS	1 to 60, 66, 72, 75, 88, 90 FPS
Imager Mode	Shooting frame rate																																			
	ProRes 4K / QFHD																																			
	4444	422 HQ																																		
6K 17:9	1 to 60 FPS	1 to 60, 66, 72 FPS																																		
5.7K 16:9																																				
6K 2.39:1	1 to 60 FPS	1 to 60, 66, 72, 75 FPS																																		
4K 6:5	1 to 60 FPS	1 to 60, 66, 72 FPS																																		
4K 17:9	1 to 60 FPS	1 to 60, 66, 72, 75, 88, 90 FPS																																		
3.8K 16:9																																				
4K 17:9 Surround View	1 to 48 FPS	1 to 48 FPS																																		
3.8K 16:9 Surround View																																				
4K 2.39:1	1 to 60 FPS	1 to 60, 66, 72, 75, 88, 90 FPS																																		

**[Note]**

Shooting frame rates of 7 or lower cannot be set in the following cases.

- When Base ISO is set to ISO 3200
- When Base ISO is set to ISO 2500 and the recording format is ProRes

Item	Description
Exposure Index	<p>Sets the EI value. You can change the Base ISO setting by pressing the Change Base button (ITEM key 4) and then simultaneously pressing the two Change buttons (ITEM key 1 and ITEM key 3) on the subsequent screen. The available settings vary as follows depending on the Base ISO setting.</p> <p>MPC-3628</p> <p>Base ISO 800: 200EI/250EI/320EI/400EI/500EI/640EI/<b>800EI</b>/1000EI/1250EI/ 1600EI/2000EI/2500EI/3200EI</p> <p>Base ISO 3200: 800EI/1000EI/1250EI/1600EI/2000EI/2500EI/<b>3200EI</b>/4000EI/ 5000EI/6400EI/8000EI/10000EI/12800EI</p> <p>MPC-3626</p> <p>Base ISO 500: 125EI/160EI/200EI/250EI/320EI/400EI/<b>500EI</b>/640EI/800EI/1000EI/ 1250EI/1600EI/2000EI</p> <p>Base ISO 2500: 640EI/800EI/1000EI/1250EI/1600EI/2000EI/<b>2500EI</b>/3200EI/4000EI/ 5000EI/6400EI/8000EI/10000EI</p>
Gain	<p>Sets the base sensitivity.</p> <p>-6dB/-3dB/<b>0dB</b>/3dB/6dB/9dB/12dB/15dB/18dB</p> <p>[Note] Configurable only when an RM-B170 or other remote control unit is connected and Technical &gt; Special Configuration &gt; RM/RCP Paint Control (page 91) is set to On in the full menu.</p>
Shutter	<p>Sets the electronic shutter angle/shutter speed.</p> <p>Press the Step/Cont. button (ITEM key 1) to switch between step and continuous selection methods.</p> <p>Step: Select from up to 16 preset values registered as shutter steps. You can press the Step Edit button (ITEM key 4) to change any setting from the preset value after selection.</p> <p>Displays the following selection options depending on the Technical &gt; System Configuration &gt; Shutter Mode (page 87) setting in the full menu.</p> <p><b>Angle: Shutter angle indicator</b></p> <p>Default selection options 360/180/172.8/144/90/45/22.5/11.2/5.6</p> <p><b>Speed: Shutter speed indicator</b></p> <p>Default selection options 1/24, 1/25, 1/30, 1/50, 1/60, 1/100, 1/120, 1/250, 1/500, 1/1000, 1/2000<sup>1)</sup></p> <p>[Note] The default speed values for different Project Frame Rate (page 54) settings are given below. 23.98/24: 1/24, 25: 1/25, 29.97: 1/30, 47.95: 1/48, 50: 1/50, 59.94: 1/60</p> <p>Cont.: Select an angle/speed within the supported range.</p>

Item	Description
ND Filter	<p>Sets the ND filter position. The following settings are available.</p> <p><b>Clear</b>/0.3/0.6/0.9/1.2/1.5/1.8/2.1/2.4</p>
LUT	<p>Configures settings related to the LUT to apply to the output video. The settings will vary depending on the Technical &gt; Special Configuration &gt; RM/RCP Paint Control (page 91) setting in the full menu.</p> <p>SDI 1/2</p> <p>When RM/RCP Paint Control is set to Off: Log/<b>Look</b> Selects the LUT to apply to the SDI 1/2 output image.</p> <p>When RM/RCP Paint Control is set to On: <b>Log</b>/HLG(Natural)/HLG(Live)/ User Gamma The SDI 1/2 output image setting is display only, because it is determined by the Project category &gt; Input Color Space setting in the menu.</p> <p>SDI 3/4</p> <p>When RM/RCP Paint Control is set to Off: Log/<b>Look</b> Selects the LUT to apply to the SDI 3/4 output image.</p> <p>When RM/RCP Paint Control is set to On: <b>Log</b>/HLG(Natural)/HLG(Live)/ User Gamma The SDI 3/4 output image setting is display only, because it is determined by the Project category &gt; Input Color Space setting in the menu.</p> <p>Monitor</p> <p>When RM/RCP Paint Control is set to Off: Selects the LUT to apply to the Monitor output image. The settings change as follows depending on the Project category &gt; Input Color Space setting in the menu. S-Gamut3.Cine/SLog3 or S-Gamut3/SLog3: Log/<b>s709</b>/R709(800%)/ Look ACEScct: Log/s709/R709(800%)/<b>Look</b></p> <p>When RM/RCP Paint Control is set to On: Selects the type of Monitor output image. The settings change as follows depending on the Project category &gt; Input Color Space setting in the menu. S-Gamut3.Cine/SLog3 or S-Gamut3/SLog3: <b>Log</b>/R709(800%) HLG(Natural): <b>HLG(Natural)</b>/R709(800%) HLG(Live): <b>HLG(Live)</b>/R709(800%) Rec.2020/User Gamma: <b>User Gamma</b>/R709-Like Rec.709/User Gamma: User Gamma</p>

Item	Description
	<p>Viewfinder</p> <p>When RM/RCP Paint Control is set to Off:  Selects the LUT to apply to the viewfinder/monitor screen output image.  The settings change as follows depending on the Project category &gt; Input Color Space setting in the menu.  S-Gamut3.Cine/SLog3 or S-Gamut3/SLog3: Log/<a href="#">s709</a>/R709(800%)/Look  ACEScct: Log/s709/R709(800%)/<a href="#">Look</a></p> <p>When RM/RCP Paint Control is set to On:  Selects the type of viewfinder/monitor screen output image.  The settings change as follows depending on the Project category &gt; Input Color Space setting in the menu.  S-Gamut3.Cine/SLog3 or S-Gamut3/SLog3: Log/<a href="#">R709(800%)</a>  HLG(Natural): HLG(Natural)  HLG(Live): HLG(Live)  Rec.2020/User Gamma: User Gamma/<a href="#">R709-Like</a>  Rec.709/User Gamma: User Gamma</p> <p>ProRes(Recording)</p> <p>When RM/RCP Paint Control is set to Off: Log/<a href="#">Look</a>  Selects the LUT to apply to the ProRes recording image.</p> <p>When RM/RCP Paint Control is set to On: <a href="#">Log</a>/HLG(Natural)/HLG(Live)/User Gamma  The ProRes recording image setting is display only, because it is determined by the Project category &gt; Input Color Space setting in the menu.</p> <p><b>[Note]</b>  Displayed and configurable when Project &gt; Basic Setting &gt; Recording Format (page 72) is set to ProRes format in the full menu.</p> <p>Edit Look  Sets a LUT to apply as a Look.  s709 / R709(800%) / S-Gamut3.Cine/SLog3 / S-Gamut3/SLog3 / User 3D LUT</p>
WB (White Balance)	<p>Sets the color temperature/color tone of the white balance.  Default selection options  <a href="#">3200K+00</a>/4300K+00/5500K+00  You can press the Step Edit button (ITEM key 4) to change the white balance preset value and Tint value.  Auto White Bal.: Execute auto white balance.</p>

1) The options are 1/60 and subsequent values when the project frame rate is 59.94, 1/50 and subsequent values when 50.0, 1/30 and subsequent values when 29.97, and 1/25 and subsequent values when 25.0.

# User Functions Screen

You can press the USER button (page 11) to display the user functions screen on the sub display and use the ITEM keys 1 to 5 as assignable buttons (User 1 to 5).

There are also four assignable buttons (1 to 4) (pages 9, 10, 11) on the unit and three assignable buttons (VF A to VF C) on the viewfinder (DVF-EL200) to which you can assign various functions.

Functions can be assigned to these buttons using the user functions screen, in addition to using Project > Assignable Button in the full menu.

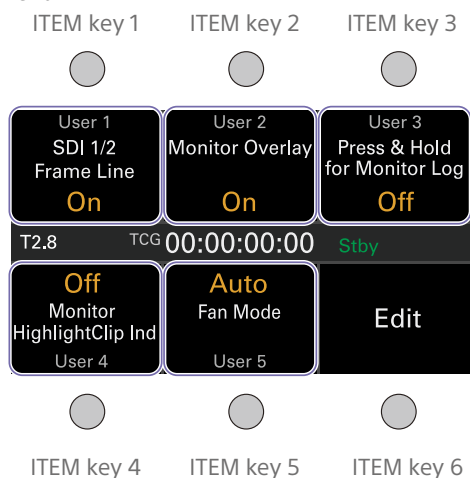

## [Note]

When a lens that supports the iris setting display function is attached, the iris position is displayed in the center left of the user functions screen.

## Changing Button Functions

The user functions selection screen is displayed by pressing the Edit button (ITEM key 6) on the user functions screen. You can set the functions for the User 1 to 5 buttons, assignable buttons 1 to 4, and viewfinder assignable buttons A to C on the user functions selection screen.

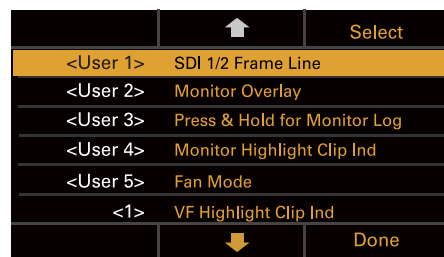

- 1 On the user functions selection screen, move the cursor to the button you want to change, and press the Select button (ITEM key 3).

The functions that can be selected are displayed.

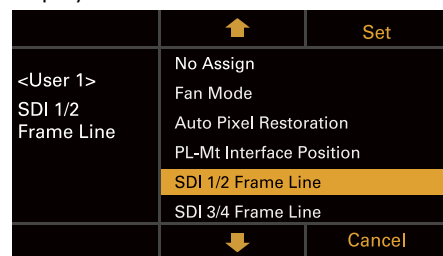

- 2 Use the ↑ button (ITEM key 2), ↓ button (ITEM key 5), or MENU dial to change the setting.
- 3 When finished, press the Set button (ITEM key 3). The display returns to the user functions screen, and displays the changed function.

The following table lists the functions that are assigned when the unit is shipped from the factory.

Button	Function	Assignable Button setting
Assignable 1	Displays clipped highlight areas in red in the viewfinder.	VF Highlight Clip Ind
Assignable 2	No assignment	Not Assigned
Assignable 3	No assignment	Not Assigned
Assignable 4	No assignment	Not Assigned
ITEM key 1	No assignment	Not Assigned
ITEM key 2	No assignment	Not Assigned
ITEM key 3	No assignment	Not Assigned
ITEM key 4	Displays clipped highlight areas in red on the Monitor output.	Monitor Highlight Clip Ind
ITEM key 5	Sets the fan control mode.	Fan Mode
Viewfinder assignable A	Turns the focus magnifier function of the viewfinder on/off.	VF Focus Magnifier
Viewfinder assignable B	Turns the false color function display in a viewfinder on/off.	VF False Color
Viewfinder assignable C	Turns the information display on the viewfinder/monitor screen output image on/off.	VF Overlay

## Functions that can be Assigned to ITEM Keys 1 to 5

Assignable Button setting	Function	State after rebooting
No Assign	No assignment	–
Fan Mode	Sets the fan control mode. Switches between Auto → Max → Off in Rec/ Auto → Off in Rec/Max each time the key is pressed.	Setting retained
Auto Pixel Restoration	Executes auto pixel restoration.	–
PL-Mt Interface Position	Sets the interface position of the PL-mount lens. Switches between Top → Side → Off each time the key is pressed.	Setting retained



Assignable Button setting	Function	State after rebooting
SDI 1/2 Frame Line	Turns superimposition of frame lines on the SDI 1/2 output image on/off.	Setting retained
SDI 3/4 Frame Line	Turns superimposition of frame lines on the SDI 3/4 output image on/off.	Setting retained
SDI Overlay	Turns display of information on the SDI output image on/off.	Setting retained
Press&Hold for SDI12 Log	Disables the LUT applied to the SDI 1/2 output image while the button is pressed, and sets Log image quality without applying a LUT.	Setting not retained
Press&Hold for SDI34 Log	Disables the LUT applied to the SDI 3/4 output image while the button is pressed, and sets Log image quality without applying a LUT. When the SDI 3/4 output and Monitor output are linked, Press & Hold for Moni Log is also enabled.	Setting not retained
Monitor Frame Line	Turns superimposition of frame lines on the Monitor output image on/off.	Setting retained
Monitor Overlay	Turns display of information on the Monitor output image on/off.	Setting retained
Press & Hold for Moni Log <sup>4)</sup>	Disables the LUT applied to the Monitor output image while the key is pressed for normal image quality without applying a LUT. When the SDI 3/4 output and Monitor output are linked, Press&Hold for SDI34 Log is also enabled. When the HDMI output and Monitor output are linked, HDMI output is also enabled.	Setting not retained
Monitor Focus Magnifier <sup>2)3)</sup>	Turns the focus magnifier function of the Monitor output image on/off.	Setting not retained
Monitor Highlight Clip Ind <sup>1)</sup>	Turns the function that displays clipped highlight areas in red on the Monitor output image on/off.	Setting retained
Monitor False Color <sup>1)</sup>	Turns the false color function display on a monitor on/off.	Setting retained
Line A: Aspect Ratio Disp.	Turns the Aspect Ratio display for Line A on/off.	Setting retained
Line B: Aspect Ratio Disp.	Turns the Aspect Ratio display for Line B on/off.	Setting retained

Assignable Button setting	Function	State after rebooting
Line A: User Frame Disp.	Turns the User Frame Line 1 and User Frame Line 2 display for Line A on/off. Each time the key is pressed, the display switches between User Frame Line 1 and 2 display → User Frame Line 1 display → User Frame Line 2 display → User Frame Line 1 and 2 hidden.	Setting retained
Line B: User Frame Disp.	Turns the User Frame Line 1 and User Frame Line 2 display for Line B on/off. Each time the key is pressed, the display switches between User Frame Line 1 and 2 display → User Frame Line 1 display → User Frame Line 2 display → User Frame Line 1 and 2 hidden.	Setting retained
H & V Flip <sup>7)</sup>	Flips the shooting mode image orientation.	Setting retained
Anamorphic De-Squeeze	Changes the Project > Basic Setting > Anamo. De-Squeeze setting in the full menu. Each time the key is pressed, the setting changes to the next item in the list of menu selection options.	Setting retained
Auto White Balance <sup>5)</sup>	Executes auto white balance.	–
Color Bars <sup>5)</sup>	Turns color bars on/off.	Setting retained
Picture Cache Rec	Turns the picture cache recording function on/off.	Setting retained
AXS Slot Change	Switches the active slot when two AXS memory cards are inserted. Switches between A and B each time the key is pressed.	Setting retained
Format Media AXS Slot A	Formats media in AXS slot A.	–
Format Media AXS Slot B	Formats media in AXS slot B.	–
Iris Open (1/16 stop) <sup>6)</sup>	Opens the lens iris. Press and hold to open the iris until fully open. This function is available when an E-mount lens with power iris is attached. The setting is in 1/16 stop increments, whereas the iris indication is in units of 1/3 stop increments.	–

Assignable Button setting	Function	State after rebooting
Iris Close (1/16 stop) <sup>6)</sup>	Closes the lens iris. Press and hold to close the iris until fully closed. This function is available when an E-mount lens with power iris is attached. The setting is in 1/16 stop increments, whereas the iris indication is in units of 1/3 stop increments.	-

- 1) Does not function if the key is pressed when Technical > Special Configuration > RM/RCP Paint Control (page 91) is set to On in the full menu.
- 2) Also applied to the HDMI output if the HDMI output has the same output format as the Monitor output. You can check the setting using Monitoring > Overlays/Frame Line > HDMI (page 79) in the full menu. The HDMI output is the same as the Monitor output if HDMI is set to "Same as Monitor".
- 3) If the SDI output format is 1920x1080i, the focus magnifier function is off, and pressing the button performs no function.
- 4) Switches to the same image as the main signal that is selected using Project > Basic Setting > Input Color Space (page 72) in the full menu while the button is pressed.
- 5) Does not function if the key is pressed when an RM-B170 or other remote control unit is connected and Technical > Special Configuration > RM/RCP Paint Control (page 91) is set to On in the full menu.
- 6) Does not function if the key is pressed when an RM-B170 or other remote control unit is connected.
- 7) Does not function if the key is pressed when Monitoring > Output Display > Flip Image (page 77) > H & V Flip in the full menu is grayed out.

## Functions that can be Assigned to Assignable Buttons 1 to 4

Assignable Button setting	Function	State after rebooting
No Assign	No assignment	-
SDI 1/2 Frame Line	Turns superimposition of frame lines on the SDI 1/2 output image on/off.	Setting retained
SDI 3/4 Frame Line	Turns superimposition of frame lines on the SDI 3/4 output image on/off.	Setting retained
SDI Overlay	Turns display of information on the SDI output image on/off.	Setting retained
Press&Hold for SDI12 Log	Disables the LUT applied to the SDI 1/2 output image while the button is pressed, and sets Log image quality without applying a LUT.	Setting not retained
Press&Hold for SDI34 Log	Disables the LUT applied to the SDI 3/4 output image while the button is pressed, and sets Log image quality without applying a LUT. When the SDI 3/4 output and Monitor output are linked, Press & Hold for Moni Log is also enabled.	Setting not retained
Monitor Frame Line	Turns superimposition of frame lines on the Monitor output image on/off.	Setting retained
Monitor Overlay	Turns display of information on the Monitor output image on/off.	Setting retained
Press & Hold for Moni Log <sup>4)</sup>	Disables the LUT applied to the Monitor output image while the key is pressed for normal image quality without applying a LUT. When the SDI 3/4 output and Monitor output are linked, Press&Hold for SDI34 Log is also enabled. When the HDMI output and Monitor output are linked, HDMI output is also enabled.	Setting not retained
Monitor Focus Magnifier <sup>2)3)</sup>	Turns the focus magnifier function of the Monitor output image on/off.	Setting not retained
Monitor Highlight Clip Ind <sup>1)</sup>	Turns the function that displays clipped highlight areas in red on the Monitor output image on/off.	Setting retained

Assignable Button setting	Function	State after rebooting
Monitor High/Low Key <sup>1)</sup>	Selects the Monitor output mode. Switches between High Key (screen for checking for blown-out highlights) → Low Key (screen for checking for blocked-out shadows) → Off (normal display) each time the button is pressed.	Setting not retained
Monitor False Color <sup>1)</sup>	Turns the false color function display on a monitor on/off.	Setting retained
VF Frame Line	Turns superimposition of frame lines on the viewfinder/monitor screen output image on/off.	Setting retained
VF Overlay	Turns the information display on the viewfinder/monitor screen output image on/off.	Setting retained
Press & Hold for VF Log <sup>6)</sup>	Disables the LUT applied to the viewfinder/monitor screen output image while the button is pressed for normal image quality without applying a LUT.	Setting not retained
VF Focus Magnifier	Turns the focus magnifier function of the viewfinder on/off.	Setting not retained
VF Highlight Clip Ind <sup>1)</sup>	Turns the function to display clipped highlight areas in red in the viewfinder on/off.	Setting retained
VF High/Low Key <sup>1)</sup>	Selects the viewfinder output mode. Switches between High Key (screen for checking for blown-out highlights) → Low Key (screen for checking for blocked-out shadows) → Off (normal display) each time the button is pressed.	Setting not retained
VF False Color <sup>1)</sup>	Turns the false color function display in a viewfinder on/off.	Setting retained
VF Zebra	Turns the zebra function of the viewfinder/monitor screen output image on/off.	Setting retained
Line A: Aspect Ratio Disp.	Turns the Aspect Ratio display for Line A on/off.	Setting retained
Line B: Aspect Ratio Disp.	Turns the Aspect Ratio display for Line B on/off.	Setting retained

Assignable Button setting	Function	State after rebooting
Line A: User Frame Disp.	Turns the User Frame Line 1 and User Frame Line 2 display for Line A on/off. Each time the button is pressed, the display switches between User Frame Line 1 and 2 display → User Frame Line 1 display → User Frame Line 2 display → User Frame Line 1 and 2 hidden.	Setting retained
Line B: User Frame Disp.	Turns the User Frame Line 1 and User Frame Line 2 display for Line B on/off. Each time the button is pressed, the display switches between User Frame Line 1 and 2 display → User Frame Line 1 display → User Frame Line 2 display → User Frame Line 1 and 2 hidden.	Setting retained
H & V Flip <sup>8)</sup>	Flips the shooting mode image orientation.	Setting retained
Anamorphic De-Squeeze	Changes the Project > Basic Setting > Anamo. De-Squeeze setting in the full menu. Each time the button is pressed, the setting changes to the next item in the list of menu selection options.	Setting retained
Auto White Balance <sup>5)</sup>	Executes auto white balance.	-
Color Bars <sup>5)</sup>	Turns color bars on/off.	Setting retained
Rec	Starts/stops recording.	-
Rec Review	Executes the Rec Review function.	Setting not retained
Picture Cache Rec	Turns the picture cache recording function on/off.	Setting retained
AXS Slot Change	Switches the active slot when two AXS memory cards are inserted. Switches between A and B each time the button is pressed.	Setting retained
ND +1stop	Switches the ND filter one stop in the darker direction.	-
ND -1stop	Switches the ND filter one stop in the brighter direction.	-

Assignable Button setting	Function	State after rebooting
Iris Open (1/16 stop) <sup>7)</sup>	Opens the lens iris. Press and hold to open the iris until fully open. This function is available when an E-mount lens with power iris is attached. The setting is in 1/16 stop increments, whereas the iris indication is in units of 1/3 stop increments.	–
Iris Close (1/16 stop) <sup>7)</sup>	Closes the lens iris. Press and hold to close the iris until fully closed. This function is available when an E-mount lens with power iris is attached. The setting is in 1/16 stop increments, whereas the iris indication is in units of 1/3 stop increments.	–

- 1) Does not function if the button is pressed when Technical > Special Configuration > RM/RCP Paint Control (page 91) is set to On in the full menu.
- 2) Also applied to the HDMI output if the HDMI output has the same output format as the Monitor output. You can check the setting using Monitoring > Overlays/Frame Line > HDMI (page 79) in the full menu. The HDMI output is the same as the Monitor output if HDMI is set to "Same as Monitor".
- 3) If the SDI output format is 1920×1080i, the focus magnifier function is off, and pressing the button performs no function.
- 4) Switches to the same image as the main signal that is selected using Project > Basic Setting > Input Color Space (page 72) in the full menu while the button is pressed.
- 5) Does not function if the button is pressed when an RM-B170 or other remote control unit is connected and Technical > Special Configuration > RM/RCP Paint Control (page 91) is set to On in the full menu.
- 6) When Technical > Special Configuration > RM/RCP Paint Control (page 91) is set to On and Shooting > LUT Select > VF LUT (page 70) is set to R709(800%) or R709-Like in the full menu, this switches to the same image as the main signal while the button is pressed. When RM/RCP Paint Control is set to Off and VF LUT is not set to Log, this switches to the same image as the main signal while the button is pressed.
- 7) Does not function if the button is pressed when an RM-B170 or other remote control unit is connected.
- 8) Does not function if the button is pressed when Monitoring > Output Display > Flip Image (page 77) > H & V Flip in the full menu is grayed out.

## Functions that can be Assigned to Viewfinder (DVF-EL200) Assignable Buttons A to C

Assignable Button setting	Function	State after rebooting
No Assign	No assignment	–
VF Frame Line	Turns superimposition of frame lines on the viewfinder/monitor screen output image on/off.	Setting retained
VF Overlay	Turns the information display on the viewfinder/monitor screen output image on/off.	Setting retained
Press & Hold for VF Log <sup>2)</sup>	Disables the LUT applied to the viewfinder/monitor screen output image while the button is pressed for normal image quality without applying a LUT.	Setting not retained
VF Focus Magnifier	Turns the focus magnifier function of the viewfinder on/off.	Setting not retained
VF Highlight Clip Ind <sup>3)</sup>	Turns the function to display clipped highlight areas in red in the viewfinder on/off.	Setting retained
VF High/Low Key <sup>3)</sup>	Selects the viewfinder output mode. Switches between High Key (screen for checking for blown-out highlights) → Low Key (screen for checking for blocked-out shadows) → Off (normal display) each time the button is pressed.	Setting not retained
VF False Color <sup>3)</sup>	Turns the false color function display in a viewfinder on/off.	Setting retained
VF Zebra	Turns the zebra function of the viewfinder/monitor screen output image on/off.	Setting retained
Line A: Aspect Ratio Disp.	Turns the Aspect Ratio display for Line A on/off.	Setting retained
Line B: Aspect Ratio Disp.	Turns the Aspect Ratio display for Line B on/off.	Setting retained
Line A: User Frame Disp.	Turns the User Frame Line 1 and User Frame Line 2 display for Line A on/off. Each time the button is pressed, the display switches between User Frame Line 1 and 2 display → User Frame Line 1 display → User Frame Line 2 display → User Frame Line 1 and 2 hidden.	Setting retained

Assignable Button setting	Function	State after rebooting
Line B: User Frame Disp.	Turns the User Frame Line 1 and User Frame Line 2 display for Line B on/off. Each time the button is pressed, the display switches between User Frame Line 1 and 2 display → User Frame Line 1 display → User Frame Line 2 display → User Frame Line 1 and 2 hidden.	Setting retained
H & V Flip <sup>5)</sup>	Flips the shooting mode image orientation.	Setting retained
Anamorphic De-Squeeze	Changes the Project > Basic Setting > Anamo. De-Squeeze setting in the full menu. Each time the button is pressed, the setting changes to the next item in the list of menu selection options.	Setting retained
Color Bars <sup>1)</sup>	Turns color bars on/off.	Setting retained
Rec	Starts/stops recording.	–
Rec Review	Executes the Rec Review function.	Setting not retained
Picture Cache Rec	Turns the picture cache recording function on/off.	Setting retained
AXS Slot Change	Switches the active slot when two AXS memory cards are inserted. Switches between A and B each time the button is pressed.	Setting retained
ND +1stop	Switches the ND filter one stop in the darker direction.	–
ND -1stop	Switches the ND filter one stop in the brighter direction.	–
Iris Open (1/16 stop) <sup>4)</sup>	Opens the lens iris. Press and hold to open the iris until fully open. This function is available when an E-mount lens with power iris is attached. The setting is in 1/16 stop increments, whereas the iris indication is in units of 1/3 stop increments.	–

Assignable Button setting	Function	State after rebooting
Iris Close (1/16 stop) <sup>4)</sup>	Closes the lens iris. Press and hold to close the iris until fully closed. This function is available when an E-mount lens with power iris is attached. The setting is in 1/16 stop increments, whereas the iris indication is in units of 1/3 stop increments.	–

- 1) Does not function if the button is pressed when an RM-B170 or other remote control unit is connected and Technical > Special Configuration > RM/RCP Paint Control (page 91) is set to On in the full menu.
- 2) Switches to the same image as the main signal that is selected using Project > Basic Setting > Input Color Space (page 72) in the full menu while the button is pressed.
- 3) Does not function if the button is pressed when Technical > Special Configuration > RM/RCP Paint Control (page 91) is set to On in the full menu.
- 4) Does not function if the button is pressed when an RM-B170 or other remote control unit is connected.
- 5) Does not function if the button is pressed when Monitoring > Output Display > Flip Image (page 77) > H & V Flip in the full menu is grayed out.

# Menu Operations

By pressing the MENU button while shooting (during recording or recording standby) or during playback, you can display and operate the menu screen on the sub display.

- Project category: Basic settings and recording format settings
- TC/Media category: Timecode value and TC format settings
- Monitoring category: SDI/HDMI/Monitor external signal output format, OSD, and marker overlay status settings
- Audio category: Audio source and audio level settings
- Info category: Camera, media, and battery status information

## Controls

### MENU button (page 10)

Press to display the menu on the sub display.

### ITEM key 1 to 6 (page 10)

Selects the category of the menu.

### SEL/SET dial (MENU dial) (page 10)

Turn to move the cursor in the corresponding direction to select setting items or setting values.

Press the MENU dial to apply the selected item.

### BACK button (page 11)

Press to return to the previous menu. Unconfirmed changes are canceled.

## Basic Operation

- 1 Press the MENU button. The menu screen appears.
- 2 Select the category to set using ITEM keys 1 to 6.
- 3 Turn the MENU dial to move the cursor to the setting item to select. For each setting item, the setting value is displayed.

"Menu Item List" (page 54)

Project	TC/Media	Monitoring
Imager Mode		8.6K 3:2
Project Frame Rate		23.98
Input Color Space		S-Gamut3/SLog3
Recording Format		X-OCN XT
De-Squeeze Ratio		Off(1.0x)
Zoom to Fit		17:9
Audio	Info	Project Details

- 4 Press the MENU dial. The setting value selection screen appears next to the selected item.

Project	TC/Media	Monitoring
Imager Mode		8.6K 3:2
Project Frame Rate		8.2K 17:9
Input Color Space		7.6K 16:9
Recording Format		5.8K 6:5
Anamo. De-Squeeze		5.8K 17:9
Zoom to Fit		5.4K 16:9
Audio	Info	Project Details

- 5 Turn the MENU dial to move the cursor to the setting value.
- 6 Press the MENU dial to apply the setting.

## Menu Item List

The items available in each category are given below.

### Project category

Default values are shown underlined and in **bold** text.

Item	Setting	Description
Imager Mode	<b>MPC-3628</b> 8.6K 3:2/8.2K 17:9/ 7.6K 16:9/5.8K 6:5/ <b>5.8K 17:9</b> /5.4K 16:9 <b>MPC-3626</b> 6K 3:2/6K 1.85:1/6K 17:9/ 6K 2.39:1/5.7K 16:9/4K 6:5/ 4K 4:3/4K 4:3 Surround View/ <b>4K 17:9</b> / 4K 17:9 Surround View/ 4K 2.39:1/3.8K 16:9/ 3.8K 16:9 Surround View	Sets the effective picture size.  [Notes] <ul style="list-style-type: none"> <li>• 5.8K 6:5 is displayed only when an Anamorphic License is installed.</li> <li>• 7.6K 16:9/8.2K 17:9/8.6K 3:2 are displayed only when a Full-Frame License is installed.</li> <li>• 6K 3:2/6K 1.85:1/6K 17:9/6K 2.39:1/5.7K 16:9 are displayed only when a Full-Frame License is installed.</li> <li>• 4K 6:5/4K 4:3/4K 4:3 Surround View are displayed only when an Anamorphic License is installed.</li> </ul>
Project Frame Rate	<b>23.98</b> /24/25/29.97/47.95/ 50/59.94	Sets the project frame rate.
Input Color Space	When RM/RCP Paint Control (page 91) is set to Off: <b>S-Gamut3.Cine/SLog3</b> / S-Gamut3/SLog3 / ACEScct When RM/RCP Paint Control is set to On: <b>S-Gamut3.Cine/SLog3</b> / S-Gamut3/SLog3 / ACEScct / HLG(Natural) / HLG(Live) / Rec.2020/ User Gamma / Rec.709/ User Gamma	Sets the color space.  [Note] HLG(Natural) is equivalent to HLG BT.2100.
Recording Format <sup>1)</sup>	X-OCN XT/ <b>X-OCN ST</b> /X-OCN LT/ProRes 4444 4K/ProRes 4444 QFHD/ProRes 422 HQ 4K/ProRes 422 HQ QFHD	Sets the recording format for AXS memory cards.

Item	Setting	Description
Anamo. De-Squeeze	<b>Off(1.0x)</b> /1.25x/1.3x/1.5x/ 1.65x/1.8x/2.0x	Sets the de-squeeze processing for ProRes recording signals and video output signals. This setting is available when an Anamorphic License is installed and Imager Mode is set to 4K 4:3/4K 4:3 Surround View/4K 6:5/4K 17:9/4K 17:9 Surround View/5.8K 6:5/5.8K 17:9, or when an Anamorphic License and Full-Frame License are installed and Imager Mode is set to 6K 3:2/6K 17:9/8.2K 17:9/8.6K 3:2. The options vary depending on the picture size.

## MPC-3628

Imager Mode	Anamo. De-Squeeze						
	Off(1.0x)	1.25x	1.3x	1.5x	1.65x	1.8x	2.0x
8.6K 3:2	Yes	Yes	Yes	Yes	Yes	Yes	Yes
8.2K 17:9	Yes	Yes	Yes	–	Yes	Yes	Yes
7.6K 16:9	Yes	–	–	–	–	–	–
5.8K 6:5	Yes	–	–	–	–	–	Yes
5.8K 17:9	Yes	Yes	Yes	–	Yes	Yes	Yes
5.4K 16:9	Yes	–	–	–	–	–	–

## MPC-3626

Imager Mode	Anamo. De-Squeeze						
	Off(1.0x)	1.25x	1.3x	1.5x	1.65x	1.8x	2.0x
6K 3:2	Yes	Yes	Yes	Yes	Yes	Yes	Yes
6K 1.85:1	Yes	–	–	–	–	–	–
6K 17:9	Yes	Yes	Yes	–	Yes	Yes	Yes
6K 2.39:1	Yes	–	–	–	–	–	–
5.7K 16:9	Yes	–	–	–	–	–	–
4K 6:5	Yes	–	–	–	–	–	Yes
4K 4:3 Surround	Yes	–	Yes	–	Yes	Yes	Yes
4K 4:3	Yes	–	Yes	–	Yes	Yes	Yes
4K 17:9 Surround	Yes	Yes	Yes	–	Yes	Yes	Yes
4K 17:9	Yes	Yes	Yes	–	Yes	Yes	Yes
4K 2.39:1	Yes	–	–	–	–	–	–
3.8K 16:9 Surround	Yes	–	–	–	–	–	–
3.8K 16:9	Yes	–	–	–	–	–	–

Item	Setting	Description
Zoom to Fit	<b>Off</b> /17:9/16:9	You can set whether to cut out and magnify the display of the recording image for the viewfinder screen or Monitor output.  [Notes] <ul style="list-style-type: none"> <li>Configurable under the following conditions. Imager Mode: 8K 3:2/6K 3:2 Recording Format: X-OCN Anamo. De-Squeeze: Off(1.0x)</li> <li>16:9 cannot be selected when Project Frame Rate is set to 47.95.</li> <li>If the setting is changed from 17:9 or 16:9 to Off, the SDI output format returns to the default setting.</li> </ul>
Project Details (ITEM key 6)		Displays the contents of the Project menu (page 72) in the full menu.

1) The recording formats available vary depending on the combination of the effective picture size and project frame rate settings. For details about settings, see "Recording Format Settings" (page 59).

## TC/Media category

Default values are shown underlined and in **bold** text.

Item	Setting	Description
TC Mode	Preset F-Run (Ext-Lk)/ <b><u>Preset R-Run</u></b> /Int Regen	Sets the timecode mode. Preset F-Run (Ext-Lk): Timecode advances continuously from specified value, regardless of whether recording or not. Preset R-Run: Timecode advances from specified value only when recording. Int Regen: Timecode continues from that of the previous clip.
	TC Display	<b><u>Timecode</u></b> /Duration
	TC Setting (set when switching to another screen)	Setting (H, M, S, F) Reset TC Format <b><u>DF/NDF</u></b> TC Source    Internal/External
Camera ID	<b><u>A</u></b> to Z	Sets the camera ID used when generating clip names. Clip name: Camera ID + Reel Number + Shot Number + date + random string
Reel Number	<b><u>001</u></b> to 999	Sets the numeric portion of the Reel Number used when generating clip names. Clip name: Camera ID + Reel Number + Shot Number + date + random string
Camera Position	<b><u>C</u></b> /L/R	Sets the first character portion of the Shot Number used when generating clip names. Clip name: Camera ID + Reel Number + Shot Number + date + random string

Item	Setting	Description
Format Media (executed when switching to another screen)	AXS Slot A	Formats the AXS memory card in slot A.
	AXS Slot B	Formats the AXS memory card in slot B.
	SD Card	Formats the SD card.
Media Details (ITEM key 6)		Displays the contents of the TC/Media menu (page 76) in the full menu.

## Monitoring category

Default values are shown underlined and in **bold** text.

### [Notes]

- The unit supports independent configuration of Status Info and Frame Line for each system. The display information for the A and B output images is configured using the Monitoring menu (page 77).
- Info and Frame Line may not be displayed depending on the Output Format setting. In this case, “-” is displayed and the setting cannot be changed.

Item	Setting	Description
VF	Overlay <b><u>Info A</u></b> /Info B/Rec Ind./Off	Selects the information to display superimposed on the viewfinder image.
	Frame Line    Line A/Line B/ <b><u>Off</u></b>	Selects the frame lines to display superimposed on the viewfinder image.
SDI 1/2	Output Format	The available settings vary according to the imager mode, project frame rate, and recording format settings.
	Overlay    Info A/ <b><u>Info B</u></b> /Rec Ind./Off	Information display is not superimposed on the SDI 1/2 output.
	Frame Line    Line A/Line B/ <b><u>Off</u></b>	Selects the frame lines to display superimposed on the SDI 1/2 output.

[Note]  
Frame lines are only superimposed if the output format is 4K/QFHD.



Item	Setting	Description
SDI 3/4 <b>[Note]</b> Depending on the Output Format setting of SDI 1/2, the Output Format, Info, Frame Line settings of SDI 3/4 may be blank and cannot be changed.	Output Format	The available settings vary depending on the SDI 1/2 setting. Selects the SDI 3/4 output format. <sup>1)</sup>
	Overlay	Info A/ <b>Info B</b> /Rec Ind./Off Selects the information to display superimposed on the SDI 3/4 output.
	Frame Line	Line A/Line B/ <b>Off</b> Selects the frame lines to display superimposed on the SDI 3/4 output.
Monitor	Output Format	The available settings vary depending on the SDI 1/2 setting. Selects the Monitor output format. <sup>2)</sup>
	Overlay	Info A/ <b>Info B</b> /Rec Ind./Off Selects the information to display superimposed on the Monitor output.
	Frame Line	Line A/Line B/ <b>Off</b> Selects the frame lines to display superimposed on the Monitor output.
HDMI	Output Format	The available settings vary depending on the SDI 1/2 setting. Selects the HDMI output format. <sup>2)</sup>
	Overlay	Info A/ <b>Info B</b> /Rec Ind./Off Selects the frame lines to display superimposed on the HDMI output.
	Frame Line	Line A/Line B/ <b>Off</b> Selects the information to display superimposed on the HDMI output.
Moni. Details (ITEM key 6)		Displays the contents of the Monitoring menu (page 77) in the full menu.

1) For details about formats available for selection, see "SDI OUT Connector Output Formats" (page 125).

2) For details about formats available for selection, see "MONITOR OUT Connector/HDMI OUT Connector Output Formats" (page 130).

## Audio category

Default values are shown underlined and in **bold** text.

Item	Setting	Description
Source Switch	LINE / AES/EBU / MIC	Displays the position of the AUDIO IN switch (page 10) that sets the CH-1 and CH-2 input source.  <b>[Note]</b> When Audio > Audio Input > Internal Mic Select (page 84) is set to CH-1/CH-2 in the full menu, the Source Switch input source is applied to CH-3 and CH-4.

Item	Setting	Description
XLR Audio L Level	Auto/Manual/Fixed -99 to <b><u>±0</u></b> to +99	Automatically adjusts the audio recording when set to Auto. The audio recording level is adjusted manually when set to Manual.  <b>[Note]</b> Fixed is selected when the Source Switch input source is AES/EBU.
XLR Audio R Level	Auto/Manual/Fixed -99 to <b><u>±0</u></b> to +99	Automatically adjusts the audio recording when set to Auto. The audio recording level is adjusted manually when set to Manual.  <b>[Note]</b> Fixed is selected when the Source Switch input source is AES/EBU.
XLR Mic Reference	-60dB/ <b><u>-50dB</u></b> /-40dB	Selects the reference input level of the microphone.
Monitor CH	When Monitor Output CH Pair is set to CH-1/CH-2 <b><u>CH-1/CH-2</u></b> , CH-1, CH-2 When Monitor Output CH Pair is set to CH-3/CH-4 <b><u>CH-3/CH-4</u></b> , CH-3, CH-4	Selects the audio channel that is output to the headphones and speaker.
Monitor Level	<b><u>0</u></b> to 99	Adjusts the monitor audio level.
CH1 Level Meter	-	Displays the CH1 level meter.
CH2 Level Meter	-	Displays the CH2 level meter.
CH3 Level Meter	-	Displays the CH3 level meter.
CH4 Level Meter	-	Displays the CH4 level meter.
Audio Details (ITEM key 6)		Displays the contents of the Audio menu (page 84) in the full menu.

## Checking the Status using the Info Category

You can check the status of media and the battery, and check the contents of warnings and errors that are issued using the Info category. The contents of the display update in realtime as the status of the unit changes.

The Info category consists of the following nine information pages. Turn the MENU dial to switch the page.

No.	Page	Description
1	Camera Condition	Displays warning messages and error messages. When there are no messages, "All Systems are OK" is displayed at the top of the display area.
2	Firmware	Displays the serial number and firmware version of the unit.
3	License	Displays the name and installation status/validity of option software licenses. If an option is not added, "Not Installed" or "Expired" is displayed for the installation status.
4	System	<p>Displays the following system information.</p> <ul style="list-style-type: none"> <li>• Date and time</li> <li>• Fan rotation speed</li> <li>• Sensor detection temperature</li> <li>• Hours meter</li> <li>• IP Address</li> </ul> <p><b>[Notes]</b></p> <ul style="list-style-type: none"> <li>• If the sensor detection temperature reaches 65 °C (149 °F), a high temperature warning message is issued.</li> <li>• "0.0.0.0" is displayed if the IP address cannot be obtained.</li> </ul>
5	Battery	<p>Displays the following battery information.</p> <ul style="list-style-type: none"> <li>• Detected battery name or type</li> <li>• Remaining capacity (%)</li> <li>• Estimated remaining time</li> <li>• Remaining capacity (Ah)</li> <li>• Voltage (V)</li> <li>• Number of times that the battery has been charged</li> <li>• Power source</li> <li>• Supplied power source voltage</li> </ul>
6	Media	Displays the remaining capacity, remaining recording time, and lifespan data of AXS memory cards and SD cards.

No.	Page	Description
7	Lens	<p>Displays the following information for the lens attached to the unit.</p> <ul style="list-style-type: none"> <li>• Lens model name</li> <li>• T value of iris</li> </ul> <p><b>[Note]</b> The F-stop value is displayed instead of the T-stop value if the T-stop value cannot be obtained.</p> <ul style="list-style-type: none"> <li>• Focal length</li> <li>• Focus distance</li> <li>• Depth of field</li> <li>• Serial number</li> </ul>
8	Network	<p>Displays the network connection setup information.</p> <ul style="list-style-type: none"> <li>• Status (LAN/Wireless Access Point/Wireless Station/Off)</li> <li>• IP Address</li> <li>• SSID</li> <li>• MAC Address</li> </ul> <p><b>[Note]</b> "0.0.0.0" is displayed if the IP address cannot be obtained.</p>
9	False Color Setting Table	<p>Displays the following False Color setup information.</p> <ul style="list-style-type: none"> <li>• Set color</li> <li>• Setting minimum value to maximum value</li> <li>• Description</li> </ul> <p><b>[Note]</b> If the setting minimum value to maximum value is different from the initial values, the text color becomes gray.</p>

## Recording Format Settings

The following recording formats can be selected for different combinations of effective picture size and project frame rate settings.

### MPC-3628

Effective picture size (Imager Mode)	Recording format	Project Frame Rate						
		23.98	24.00	25.00	29.97	47.95	50.00	59.94
8.6K 3:2	X-OCN XT	Yes	Yes	Yes	Yes	-	-	-
	X-OCN ST	Yes	Yes	Yes	Yes	-	-	-
	X-OCN LT	Yes	Yes	Yes	Yes	-	-	-
	4K ProRes 4444	-	-	-	-	-	-	-
	QFHD ProRes 4444	-	-	-	-	-	-	-
	4K ProRes 422 HQ	-	-	-	-	-	-	-
	QFHD ProRes 422 HQ	-	-	-	-	-	-	-
8.2K 17:9	X-OCN XT	Yes	Yes	Yes	Yes	-	-	-
	X-OCN ST	Yes	Yes	Yes	Yes	Yes	Yes	Yes
	X-OCN LT	Yes	Yes	Yes	Yes	Yes	Yes	Yes
	4K ProRes 4444	Yes	Yes	Yes	Yes	-	Yes	Yes
	QFHD ProRes 4444	-	-	-	-	-	-	-
	4K ProRes 422 HQ	Yes	Yes	Yes	Yes	-	Yes	Yes
	QFHD ProRes 422 HQ	-	-	-	-	-	-	-
7.6K 16:9	X-OCN XT	Yes	Yes	Yes	Yes	-	-	-
	X-OCN ST	Yes	Yes	Yes	Yes	-	Yes	Yes
	X-OCN LT	Yes	Yes	Yes	Yes	-	Yes	Yes
	4K ProRes 4444	-	-	-	-	-	-	-
	QFHD ProRes 4444	Yes	Yes	Yes	Yes	-	Yes	Yes
	4K ProRes 422 HQ	-	-	-	-	-	-	-
	QFHD ProRes 422 HQ	Yes	Yes	Yes	Yes	-	Yes	Yes
5.8K 6:5	X-OCN XT	Yes	Yes	Yes	Yes	Yes	-	-
	X-OCN ST	Yes	Yes	Yes	Yes	Yes	-	-
	X-OCN LT	Yes	Yes	Yes	Yes	Yes	-	-
	4K ProRes 4444	Yes	Yes	Yes	Yes	-	-	-
	QFHD ProRes 4444	-	-	-	-	-	-	-
	4K ProRes 422 HQ	Yes	Yes	Yes	Yes	-	-	-
	QFHD ProRes 422 HQ	-	-	-	-	-	-	-

Effective picture size (Imager Mode)	Recording format	Project Frame Rate						
		23.98	24.00	25.00	29.97	47.95	50.00	59.94
5.8K 17:9	X-OCN XT	Yes	Yes	Yes	Yes	Yes	Yes	Yes
	X-OCN ST	Yes	Yes	Yes	Yes	Yes	Yes	Yes
	X-OCN LT	Yes	Yes	Yes	Yes	Yes	Yes	Yes
	4K ProRes 4444	Yes	Yes	Yes	Yes	-	Yes	Yes
	QFHD ProRes 4444	-	-	-	-	-	-	-
	4K ProRes 422 HQ	Yes	Yes	Yes	Yes	-	Yes	Yes
	QFHD ProRes 422 HQ	-	-	-	-	-	-	-
5.4K 16:9	X-OCN XT	Yes	Yes	Yes	Yes	-	Yes	Yes
	X-OCN ST	Yes	Yes	Yes	Yes	-	Yes	Yes
	X-OCN LT	Yes	Yes	Yes	Yes	-	Yes	Yes
	4K ProRes 4444	-	-	-	-	-	-	-
	QFHD ProRes 4444	Yes	Yes	Yes	Yes	-	Yes	Yes
	4K ProRes 422 HQ	-	-	-	-	-	-	-
	QFHD ProRes 422 HQ	Yes	Yes	Yes	Yes	-	Yes	Yes

## MPC-3626

Effective picture size (Imager Mode)	Recording format	Project Frame Rate						
		23.98	24.00	25.00	29.97	47.95	50.00	59.94
6K 3:2	X-OCN XT	Yes	Yes	Yes	Yes	Yes	Yes	Yes
	X-OCN ST	Yes	Yes	Yes	Yes	Yes	Yes	Yes
	X-OCN LT	Yes	Yes	Yes	Yes	Yes	Yes	Yes
	4K ProRes 4444	-	-	-	-	-	-	-
	QFHD ProRes 4444	-	-	-	-	-	-	-
	4K ProRes 422 HQ	-	-	-	-	-	-	-
	QFHD ProRes 422 HQ	-	-	-	-	-	-	-
6K 1.85:1	X-OCN XT	Yes	Yes	Yes	Yes	Yes	Yes	Yes
	X-OCN ST	Yes	Yes	Yes	Yes	Yes	Yes	Yes
	X-OCN LT	Yes	Yes	Yes	Yes	Yes	Yes	Yes
	4K ProRes 4444	-	-	-	-	-	-	-
	QFHD ProRes 4444	-	-	-	-	-	-	-
	4K ProRes 422 HQ	-	-	-	-	-	-	-

Effective picture size (Imager Mode)	Recording format	Project Frame Rate						
		23.98	24.00	25.00	29.97	47.95	50.00	59.94
6K 17:9	X-OCN XT	Yes	Yes	Yes	Yes	Yes	Yes	Yes
	X-OCN ST	Yes	Yes	Yes	Yes	Yes	Yes	Yes
	X-OCN LT	Yes	Yes	Yes	Yes	Yes	Yes	Yes
	4K ProRes 4444	Yes	Yes	Yes	Yes	-	Yes	Yes
	QFHD ProRes 4444	-	-	-	-	-	-	-
	4K ProRes 422 HQ	Yes	Yes	Yes	Yes	-	Yes	Yes
	QFHD ProRes 422 HQ	-	-	-	-	-	-	-
6K 2.39:1	X-OCN XT	Yes	Yes	Yes	Yes	Yes	Yes	Yes
	X-OCN ST	Yes	Yes	Yes	Yes	Yes	Yes	Yes
	X-OCN LT	Yes	Yes	Yes	Yes	Yes	Yes	Yes
	4K ProRes 4444	Yes	Yes	Yes	Yes	-	Yes	Yes
	QFHD ProRes 4444	-	-	-	-	-	-	-
	4K ProRes 422 HQ	Yes	Yes	Yes	Yes	-	Yes	Yes
	QFHD ProRes 422 HQ	-	-	-	-	-	-	-
5.7K 16:9	X-OCN XT	Yes	Yes	Yes	Yes	-	Yes	Yes
	X-OCN ST	Yes	Yes	Yes	Yes	-	Yes	Yes
	X-OCN LT	Yes	Yes	Yes	Yes	-	Yes	Yes
	4K ProRes 4444	-	-	-	-	-	-	-
	QFHD ProRes 4444	Yes	Yes	Yes	Yes	-	Yes	Yes
	4K ProRes 422 HQ	-	-	-	-	-	-	-
	QFHD ProRes 422 HQ	Yes	Yes	Yes	Yes	-	Yes	Yes
4K 6:5	X-OCN XT	Yes	Yes	Yes	Yes	Yes	Yes	Yes
	X-OCN ST	Yes	Yes	Yes	Yes	Yes	Yes	Yes
	X-OCN LT	Yes	Yes	Yes	Yes	Yes	Yes	Yes
	4K ProRes 4444	Yes	Yes	Yes	Yes	-	Yes	Yes
	QFHD ProRes 4444	-	-	-	-	-	-	-
	4K ProRes 422 HQ	Yes	Yes	Yes	Yes	-	Yes	Yes
	QFHD ProRes 422 HQ	-	-	-	-	-	-	-
4K 4:3	X-OCN XT	Yes	Yes	Yes	Yes	Yes	Yes	Yes
	X-OCN ST	Yes	Yes	Yes	Yes	Yes	Yes	Yes
	X-OCN LT	Yes	Yes	Yes	Yes	Yes	Yes	Yes
	4K ProRes 4444	-	-	-	-	-	-	-
	QFHD ProRes 4444	-	-	-	-	-	-	-
	4K ProRes 422 HQ	-	-	-	-	-	-	-
	QFHD ProRes 422 HQ	-	-	-	-	-	-	-

Effective picture size (Imager Mode)	Recording format	Project Frame Rate						
		23.98	24.00	25.00	29.97	47.95	50.00	59.94
4K 4:3 Surround	X-OCN XT	Yes	Yes	Yes	Yes	-	-	-
	X-OCN ST	Yes	Yes	Yes	Yes	-	-	-
	X-OCN LT	Yes	Yes	Yes	Yes	-	-	-
	4K ProRes 4444	-	-	-	-	-	-	-
	QFHD ProRes 4444	-	-	-	-	-	-	-
	4K ProRes 422 HQ	-	-	-	-	-	-	-
	QFHD ProRes 422 HQ	-	-	-	-	-	-	-
4K 17:9	X-OCN XT	Yes	Yes	Yes	Yes	Yes	Yes	Yes
	X-OCN ST	Yes	Yes	Yes	Yes	Yes	Yes	Yes
	X-OCN LT	Yes	Yes	Yes	Yes	Yes	Yes	Yes
	4K ProRes 4444	Yes	Yes	Yes	Yes	-	Yes	Yes
	QFHD ProRes 4444	-	-	-	-	-	-	-
	4K ProRes 422 HQ	Yes	Yes	Yes	Yes	-	Yes	Yes
	QFHD ProRes 422 HQ	-	-	-	-	-	-	-
4K 17:9 Surround	X-OCN XT	Yes	Yes	Yes	Yes	-	-	-
	X-OCN ST	Yes	Yes	Yes	Yes	-	-	-
	X-OCN LT	Yes	Yes	Yes	Yes	-	-	-
	4K ProRes 4444	Yes	Yes	Yes	Yes	-	-	-
	QFHD ProRes 4444	-	-	-	-	-	-	-
	4K ProRes 422 HQ	Yes	Yes	Yes	Yes	-	-	-
	QFHD ProRes 422 HQ	-	-	-	-	-	-	-
4K 2.39:1	X-OCN XT	Yes	Yes	Yes	Yes	Yes	Yes	Yes
	X-OCN ST	Yes	Yes	Yes	Yes	Yes	Yes	Yes
	X-OCN LT	Yes	Yes	Yes	Yes	Yes	Yes	Yes
	4K ProRes 4444	Yes	Yes	Yes	Yes	-	Yes	Yes
	QFHD ProRes 4444	-	-	-	-	-	-	-
	4K ProRes 422 HQ	Yes	Yes	Yes	Yes	-	Yes	Yes
	QFHD ProRes 422 HQ	-	-	-	-	-	-	-
3.8K 16:9	X-OCN XT	Yes	Yes	Yes	Yes	-	Yes	Yes
	X-OCN ST	Yes	Yes	Yes	Yes	-	Yes	Yes
	X-OCN LT	Yes	Yes	Yes	Yes	-	Yes	Yes
	4K ProRes 4444	-	-	-	-	-	-	-
	QFHD ProRes 4444	Yes	Yes	Yes	Yes	-	Yes	Yes
	4K ProRes 422 HQ	-	-	-	-	-	-	-
	QFHD ProRes 422 HQ	Yes	Yes	Yes	Yes	-	Yes	Yes

Effective picture size (Imager Mode)	Recording format	Project Frame Rate						
		23.98	24.00	25.00	29.97	47.95	50.00	59.94
3.8K 16:9 Surround	X-OCN XT	Yes	Yes	Yes	Yes	-	-	-
	X-OCN ST	Yes	Yes	Yes	Yes	-	-	-
	X-OCN LT	Yes	Yes	Yes	Yes	-	-	-
	4K ProRes 4444	-	-	-	-	-	-	-
	QFHD ProRes 4444	Yes	Yes	Yes	Yes	-	-	-
	4K ProRes 422 HQ	-	-	-	-	-	-	-
	QFHD ProRes 422 HQ	Yes	Yes	Yes	Yes	-	-	-

# Full Menu Operations

The full menu for configuring the required settings for shooting and playback is displayed on the sub display by pressing and holding the MENU button for 2 seconds or longer.

You can also press the MENU button together with the MENU dial to quickly display the full menu screen.

---

## Menu Structure

---

### Shooting menu

Menu used to make settings related to shooting.

### Project menu

Menu used to make basic settings for a project.

### TC/Media menu

Menu used to make settings related to timecode and recording media.

### Monitoring menu

Menu used to make settings related to video output and viewfinder output.

### Audio menu

Menu used to make settings related to audio.

### Paint menu

Menu used to make settings related to paint functions.

The Paint menu can be displayed and selected only when Technical > Special Configuration >

RM/RCP Paint Control (page 91) is set to On in the full menu.

### Technical menu

Menu used to make settings related to technical matters.

### Maintenance menu

Menu used to make unit settings, such as the clock and language settings.

---

## Controls

---

### MENU button (page 10)

Press and hold for 2 seconds or longer to display the full menu on the sub display.

### SEL/SET dial (MENU dial) (page 10)

Turn to move the cursor in the corresponding direction to select setting items or setting values.

Press the MENU dial to apply the selected item.

### BACK button (page 11)

Press to return to the previous menu. Unconfirmed changes are canceled.

---

## Setting Menu Items

---

Turn the MENU dial to move the cursor to the menu item you want to set, then press the MENU dial to select that item.

- The menu item selection area can show a maximum of nine lines. When all the selectable items cannot be displayed at one time, you can scroll the display up or down by moving the cursor.
- For items having a wide range of available values (example: -99 to +99), the selection area is not displayed. The current setting is highlighted to indicate that the value can be changed.
- If you select Run for an executable item, the corresponding function is executed.
- When you select an item that you must confirm before execution, a confirmation message appears. Follow the instructions in the message to execute or cancel the operation.



# Shooting Menu

The functions and available settings of each menu item are given below.

Default values are shown underlined and in **bold** text.

Shooting > <b>FPS</b>																										
Sets the shooting frame rate.																										
Menu item	Setting	Description																								
Fixed/Variable Select	<u>Fixed</u> /Variable	Selects whether the FPS setting is set to constant speed shooting or variable speed shooting.																								
FPS Select	When Fixed/Variable Select is set to Fixed, one of the following values is displayed. Fixed 23.98/Fixed 24.00/ Fixed 25.00/Fixed 29.97/ Fixed 47.95/Fixed 50.00/ Fixed 59.94	Selects the shooting frame rate. The default values vary as shown below depending on the Project Frame Rate setting.																								
		<table border="1"> <thead> <tr> <th>Project Frame Rate</th> <th>Default when Select is Variable</th> <th>Display value when Fixed/Variable Select is Fixed</th> </tr> </thead> <tbody> <tr> <td>59.94</td> <td>60</td> <td>Fixed 59.94</td> </tr> <tr> <td>50</td> <td>50</td> <td>Fixed 50.00</td> </tr> <tr> <td>47.95</td> <td>48</td> <td>Fixed 47.95</td> </tr> <tr> <td>29.97</td> <td>30</td> <td>Fixed 29.97</td> </tr> <tr> <td>25</td> <td>25</td> <td>Fixed 25.00</td> </tr> <tr> <td>24</td> <td>24</td> <td>Fixed 24.00</td> </tr> <tr> <td>23.97</td> <td>24</td> <td>Fixed 23.98</td> </tr> </tbody> </table>	Project Frame Rate	Default when Select is Variable	Display value when Fixed/Variable Select is Fixed	59.94	60	Fixed 59.94	50	50	Fixed 50.00	47.95	48	Fixed 47.95	29.97	30	Fixed 29.97	25	25	Fixed 25.00	24	24	Fixed 24.00	23.97	24	Fixed 23.98
Project Frame Rate	Default when Select is Variable	Display value when Fixed/Variable Select is Fixed																								
59.94	60	Fixed 59.94																								
50	50	Fixed 50.00																								
47.95	48	Fixed 47.95																								
29.97	30	Fixed 29.97																								
25	25	Fixed 25.00																								
24	24	Fixed 24.00																								
23.97	24	Fixed 23.98																								
		<p><b>[Note]</b> Shooting frame rates of 7 or lower cannot be set in the following cases.</p> <ul style="list-style-type: none"> <li>- When Base ISO is set to ISO 3200</li> <li>- When Base ISO is set to ISO 2500 and the recording format is ProRes</li> </ul>																								

Shooting > <b>Shutter</b>		
Makes settings related to the electronic shutter.		
<b>[Note]</b> Shutter is grayed out and cannot be operated when an RM-B170 or other remote control unit is connected and Technical > Special Configuration > RM/RCP Paint Control (page 91) is set to On in the full menu.		
Menu item	Setting	Description
Shutter Select	When Shutter Mode (page 87) is set to Speed Default selection options 1/24, 1/25, 1/30, 1/48, 1/50, 1/60, 1/100, 1/120, 1/250, 1/500, 1/1000, 1/2000 <sup>1)</sup> When Shutter Mode (page 87) is set to Angle Default selection options 360.0/ <b>180.0</b> /172.8/144.0/ 90.0/45.0/22.5/11.2/5.6 When Step/Cont. Select is set to Continuous, the selection range is 360.0 to 4.2 (Angle) or 1/24 <sup>1)</sup> to 1/8000 <sup>2)</sup> (Speed).	Selects shutter angle or speed of the electronic shutter. The default speed values for different Project Frame Rate (page 72) settings are given below. 23.98/24: 1/24 25: 1/25 29.97: 1/30 47.95: 1/48 50: 1/50 59.94: 1/60
Step/Cont. Select	<u>Step</u> /Continuous	1) The options are 1/60 and subsequent values when the project frame rate is 59.94, 1/50 and subsequent values when 50.0, 1/30 and subsequent values when 29.97, and 1/25 and subsequent values when 25.0. 2) The options are 1/7000 and preceding values when the project frame rate is 50.0 or 25.0, and 1/6000 and preceding values when 24.0 or 23.98.
Add/Change Step		Selects whether the electronic shutter values are step values or continuous. Adds or edits a selection option available in Shutter Select in Step mode. Up to 16 selection options can be added.
Delete Step		Deletes a selection option available in Shutter Select in Step mode.
Shooting > <b>Flicker Reduce</b>		
Makes settings related to flicker reduction.		
Menu item	Setting	Description
Mode	On/ <b>Off</b>	Turns the flicker reduction function on/off.
Frequency	50Hz/ <b>60Hz</b>	Sets the power supply frequency of lighting causing flicker.

Shooting > <b>ND</b> Sets the ND filter position.		
Menu item	Setting	Description
ND Position	<b>Clear</b> /0.3/0.6/0.9/1.2/1.5/1.8/ 2.1/2.4	Selects the density of the ND filter.

Shooting > <b>Exposure Index</b> Sets the EI value.		
<b>[Note]</b> Exposure Index is grayed out and the setting cannot be changed when Technical > Special Configuration > RM/RCP Paint Control (page 91) is set to On in the full menu.		

Menu item	Setting	Description
EI Select	The settings change as follows depending on the Project > Basic Setting > Base ISO (page 72) setting in the full menu. MPC-3628 Base ISO 800: 200EI/250EI/320EI/400EI/ 500EI/640EI/ <b>800EI</b> / 1000EI/1250EI/1600EI/ 2000EI/2500EI/3200EI Base ISO 3200: 800EI/1000EI/1250EI/ 1600EI/2000EI/2500EI/ <b>3200EI</b> /4000EI/5000EI/ 6400EI/8000EI/10000EI/ 12800EI MPC-3626 ISO 500: 125EI/160EI/200EI/250EI/ 320EI/400EI/ <b>500EI</b> /640EI/ 800EI/1000EI/1250EI/ 1600EI/2000EI ISO 2500: 640EI/800EI/1000EI/ 1250EI/1600EI/2000EI/ <b>2500EI</b> /3200EI/4000EI/ 5000EI/6400EI/8000EI/ 10000EI	Selects the EI value.  <b>[Note]</b> The settings are fixed to the following values when Technical > Special Configuration > RM/RCP Paint Control (page 91) is set to On in the full menu. When Base ISO is set to ISO500: 500EI When Base ISO is set to ISO2500: 2500EI When Base ISO is set to ISO800: 800EI When Base ISO is set to ISO3200: 3200EI

Shooting > <b>Gain</b> Makes settings related to the gain.		
<b>[Note]</b> Gain setting cannot be changed when an RM-B170 or other remote control unit is connected or Technical > Special Configuration > RM/RCP Paint Control (page 91) is set to Off in the full menu.		
Menu item	Setting	Description
Gain Select	-6dB/-3dB/ <b>0dB</b> /3dB/6dB/ 9dB/12dB/15dB/18dB	Sets the base sensitivity.

Shooting > <b>White Balance</b> Makes settings related to white balance.		
<b>[Note]</b> White Balance is grayed out and cannot be operated when an RM-B170 or other remote control unit is connected and Technical > Special Configuration > RM/RCP Paint Control (page 91) is set to On in the full menu.		

Menu item	Setting	Description
Color Temp. Select	<b>3200K+00</b> /4300K+00/ 5500K+00 + other added options (up to 16)	Displays and selects the color temperature/ color tone of the white balance.
Add/Change Step		Adds or edits a selection option by changing the color temperature and tint value of white balance.
Delete Step		Deletes an added selection option.
Auto White Balance	Run/Cancel	Executes auto white balance (execute by selecting Run).

Shooting > <b>Look</b> Makes settings related to Preset Look.		
<b>[Note]</b> Look is grayed out and the setting cannot be changed when Technical > Special Configuration > RM/RCP Paint Control (page 91) is set to On in the full menu.		

Menu item	Setting	Description
Category	<b>Preset Look</b> /User 3D LUT/ ART/ACEScct with User 3D/ ACESproxy with User 3D/ACES with ART	Selects the LUT category.  <b>[Note]</b> ACEScct with User 3D/ACESproxy with User 3D/ACES with ART can be selected only when Project > Basic Setting > Input Color Space (page 72) is set to ACEScct in the full menu.

Shooting > **Look**

Makes settings related to Preset Look.

**[Note]**

Look is grayed out and the setting cannot be changed when Technical > Special Configuration > RM/RCP Paint Control (page 91) is set to On in the full menu.

Menu item	Setting	Description
Preset Look Select	<b>s709</b> /R709(800%) / S-Gamut3.Cine/SLog3 / S-Gamut3/SLog3 / ACESproxy / ACEScct / ACES 1.0 Output-Rec.709	Selects the Preset Look. Outputs images that are suitable as the starting point for color grading or images that are close to print film quality. s709: Cinema color R709(800%): Faithful color S-Gamut3/SLog3: Wide color space S-Gamut3.Cine/SLog3: Color space for digital cinema ACESproxy: Log curve of wide color space (AP1) defined by the Academy. ACEScct: Log curve of wide color space (AP1) based on ACESproxy, with toe characteristic that reduces contrast in the curve near black. ACES 1.0 Output-Rec.709: Rec.709 reference Look defined by the Academy.  <b>[Notes]</b> <ul style="list-style-type: none"> <li>Configurable only when Category is set to Preset Look.</li> <li>S-Gamut3/SLog3 can be selected only when Project &gt; Basic Setting &gt; Input Color Space (page 72) is set to S-Gamut3/SLog3 in the full menu.</li> <li>ACESproxy/ACEScct/ACES 1.0 Output-Rec.709 can be selected only when Project &gt; Basic Setting &gt; Input Color Space (page 72) is set to ACEScct in the full menu.</li> </ul>
User 3D LUT Select	File name (01 to 16) of User 3D LUT files stored in internal memory	Selects the User 3D LUT file.  <b>[Note]</b> Configurable only when Category is set to User 3D LUT, ACEScct with User 3D, or ACESproxy with User 3D.
ART Select	File name (01 to 16) of ART files stored in internal memory	Selects the ART file.  <b>[Note]</b> Configurable only when Category is set to ART or ACES with ART.

Shooting > **Look**

Makes settings related to Preset Look.

**[Note]**

Look is grayed out and the setting cannot be changed when Technical > Special Configuration > RM/RCP Paint Control (page 91) is set to On in the full menu.

Menu item	Setting	Description
ART Information		Displays information from the ART file selected by ART Select.  <b>[Note]</b> Displayed only when Category is set to ART or ACES with ART.
ASC CDL Process	<b>CDL Off</b> /Look-> CDL/CDL -> Look/CDL On	Sets whether to apply ASC CDL to the output video. When applying, specify the ASC CDL processing sequence. CDL Off: Do not apply ASC CDL to the output video. Look -> CDL: Apply CDL after applying Look. CDL -> Look: Apply CDL before applying Look. CDL On: Apply ASC CDL to the output video.  <b>[Notes]</b> <ul style="list-style-type: none"> <li>ASC CDL is enabled for outputs for which Look is selected in Shooting &gt; LUT Select (page 68) in the full menu.</li> <li>The conditions under which the ASC CDL Process options are enabled are given in the following table.</li> </ul>

**Shooting > Look**

Makes settings related to Preset Look.

**[Note]**

Look is grayed out and the setting cannot be changed when Technical > Special Configuration > RM/RCP Paint Control (page 91) is set to On in the full menu.

Menu item	Setting	Description
ASC CDL Process	Shooting > Look Category Preset Look Select	Project > Basic Setting > Input Color Space ASC CDL Process available options
	Preset Look s709	S-Gamut3/Slog3 CDL Off S-Gamut3.Cine/Slog3 Look -> CDL CDL -> Look
	R709(800%) S-Gamut3/Slog3	S-Gamut3/Slog3 CDL Off S-Gamut3.Cine/Slog3 Look -> CDL
	S-Gamut3.Cine/ Slog3	S-Gamut3/Slog3 CDL Off Look -> CDL
		S-Gamut3.Cine/Slog3 CDL Off Look -> CDL
	ACESproxy ACEScct ACES 1.0 Output-Rec.709	ACEScct CDL Off CDL On
User 3D LUT	-	S-Gamut3/Slog3 CDL Off S-Gamut3.Cine/Slog3 Look -> CDL CDL -> Look
ART	-	S-Gamut3/Slog3 CDL Off S-Gamut3.Cine/Slog3 Look -> CDL CDL -> Look
ACEScct with User 3D ACESproxy with User 3D	-	ACEScct CDL Off CDL -> Look
ACES with ART	-	ACEScct CDL Off CDL -> Look
ASC CDL Select	<b>No File</b> /Not Selected	Selects the ASC CDL registered in the unit.
ASC CDL Information		Displays information from the ASC CDL file selected by ASC CDL Select. You can change the Saturation setting on the displayed screen.

**Shooting > Look File**

Loads a User 3D LUT file into the unit.

**[Note]**

Look File is grayed out and the setting cannot be changed when Technical > Special Configuration > RM/RCP Paint Control (page 91) is set to On in the full menu.

Menu item	Setting	Description
Load User 3D LUT		Loads a User 3D LUT file stored on an SD card into the unit.
Reset User 3D LUT		Resets a User 3D LUT data setting.
Reset All User 3D LUTs	Run/Cancel	Resets all User 3D LUT data settings (execute by selecting Run).
Load ART		Loads an ART file stored on an SD card into the unit.
Reset ART		Resets an ART data setting.
Reset All ARTs	Run/Cancel	Resets all ART data settings (execute by selecting Run).
Load ASC CDL		Loads ASC CDL data from an SD card.
Reset ASC CDL		Resets an ASC CDL data setting.
Reset All ASC CDLs	Run/Cancel	Resets all ASC CDL data settings (execute by selecting Run).

**Shooting > LUT Select**

Makes settings related to the LUT to apply to the output image.

**[Note]**

The value of each menu item (excluding SDR Gain) varies depending on the Technical > Special Configuration > RM/RCP Paint Control (page 91) setting in the full menu.

Menu item	Setting	Description
SDI 1/2	When RM/RCP Paint Control is set to Off: Log/ <b>Look</b>	Selects the LUT to apply to the SDI 1/2 output image.
	When RM/RCP Paint Control is set to On: Log/HLG(Natural)/ HLG(Live)/User Gamma	The SDI 1/2 output image setting is display only, because it is determined by the Project > Basic Setting > Input Color Space (page 72) setting in the full menu.

Shooting > **LUT Select**

Makes settings related to the LUT to apply to the output image.

**[Note]**

The value of each menu item (excluding SDR Gain) varies depending on the Technical > Special Configuration > RM/RCP Paint Control (page 91) setting in the full menu.

Menu item	Setting	Description
SDI 3/4	When RM/RCP Paint Control is set to Off: Log/ <a href="#">Look</a>	Selects the LUT to apply to the SDI 3/4 output image.  <b>[Note]</b> When SDI 1/2 output is the following, this is set to the same value as SDI 1/2 (fixed). - 4K/QFHD Quad output - 4K/QFHD Dual output When SDI 1/2 output is the following, this is set to the same value as Monitor (fixed). - 4K/QFHD 12G/6G output - 4K/QFHD Dual output
	When RM/RCP Paint Control is set to On: Log/HLG(Natural)/ HLG(Live)/User Gamma	The SDI 3/4 output image setting is display only, because it is determined by the Project > Basic Setting > Input Color Space (page 72) setting in the full menu.  <b>[Note]</b> When SDI 1/2 output is the following, this is set to the same value as Monitor (fixed). - 4K/QFHD 12G/6G output - 4K/QFHD Dual output When SDI 1/2 output is the following, this is set to the same value as SDI 1/2 (fixed). - 4K/QFHD Quad output - 4K/QFHD Dual output

Shooting > **LUT Select**

Makes settings related to the LUT to apply to the output image.

**[Note]**

The value of each menu item (excluding SDR Gain) varies depending on the Technical > Special Configuration > RM/RCP Paint Control (page 91) setting in the full menu.

Menu item	Setting	Description
Monitor	When RM/RCP Paint Control is set to Off: When Output Format > SDI 1/2 is set to 2K/HD: Log/ <a href="#">s709</a> /R709(800%)/ Look/--- When Output Format > SDI 1/2 is set to 4K/QFHD: Log/s709/R709(800%)/ <a href="#">Look</a> /---	Selects the LUT to apply to the Monitor output image.  <b>[Note]</b> There is no output and "---" (disabled) is displayed when Technical > Special Configuration > SD HDMI (page 91) is set to On in the full menu.
	When RM/RCP Paint Control is set to On, the settings change as follows depending on the Project > Basic Setting > Input Color Space (page 72) setting in the full menu. S-Gamut3.Cine/SLog3 or S-Gamut3/SLog3: <a href="#">Log</a> /R709(800%) HLG(Natural): <a href="#">HLG(Natural)</a> /R709(800%) HLG(Live): <a href="#">HLG(Live)</a> /R709(800%) Rec.2020/User Gamma: <a href="#">User Gamma</a> /R709-Like Rec.709/User Gamma: User Gamma	Selects the type of Monitor output image.  <b>[Notes]</b> <ul style="list-style-type: none"> <li>An SDR gain value (-12 dB) is applied to the viewfinder/monitor output image.</li> <li>You can change the output gain using SDR Gain when set to R709(800%) or R709-Like.</li> </ul>

Shooting > **LUT Select**

Makes settings related to the LUT to apply to the output image.

**[Note]**

The value of each menu item (excluding SDR Gain) varies depending on the Technical > Special Configuration > RM/RCP Paint Control (page 91) setting in the full menu.

Menu item	Setting	Description
HDMI	When RM/RCP Paint Control is set to Off (4K/QFHD output): Log/ <a href="#">Look</a>	Display only, because the HDMI output image setting is the same as SDI 1/2.
	When RM/RCP Paint Control is set to Off (2K/HD output): Log/ <a href="#">s709/R709(800%)/Look</a>	Display only, because the HDMI output image setting is the same as Monitor.  <b>[Note]</b> Set to Log (fixed) when Technical > Special Configuration > SD HDMI (page 91) is set to On in the full menu.
	When RM/RCP Paint Control is set to On (4K/QFHD output): <a href="#">Log</a> /HLG(Natural)/HLG(Live)/User Gamma	Display only, because the HDMI output image setting is the same as SDI 1/2.
	When RM/RCP Paint Control is set to On (2K/HD output): <a href="#">Log</a> /HLG(Natural)/HLG(Live)/User Gamma/R709(800%)/R709-Like	Display only, because the HDMI output image setting is the same as Monitor.

Shooting > **LUT Select**

Makes settings related to the LUT to apply to the output image.

**[Note]**

The value of each menu item (excluding SDR Gain) varies depending on the Technical > Special Configuration > RM/RCP Paint Control (page 91) setting in the full menu.

Menu item	Setting	Description
VF LUT	When RM/RCP Paint Control is set to Off: Log/ <a href="#">s709/R709(800%)/Look</a>	Selects the LUT to apply to the viewfinder/monitor screen output image.
	When RM/RCP Paint Control is set to On: The settings change as follows depending on the Project > Basic Setting > Input Color Space (page 72) setting in the full menu. S-Gamut3.Cine/SLog3 or S-Gamut3/SLog3: Log/ <a href="#">R709(800%)</a> HLG(Natural): HLG(Natural)/ <a href="#">R709(800%)</a> HLG(Live): HLG(Live)/ <a href="#">R709(800%)</a> Rec.2020/User Gamma: User Gamma/ <a href="#">R709-Like</a> Rec.709/User Gamma: User Gamma	Selects the type of viewfinder/monitor screen output image.  <b>[Notes]</b> <ul style="list-style-type: none"> <li>An SDR gain value (-12 dB) is applied to the viewfinder/monitor output image.</li> <li>You can change the output gain using SDR Gain when set to R709(800%) or R709-Like.</li> </ul>
ProRes	When RM/RCP Paint Control is set to Off: <a href="#">Log</a> /Look/---	Selects the LUT to apply to the ProRes recording image.  <b>[Note]</b> "---" (disabled) is displayed when Project > Basic Setting > Recording Format (page 72) is set to X-OCN format in the full menu.
	When RM/RCP Paint Control is set to On: Log/HLG(Natural)/HLG(Live)/User Gamma	The ProRes recording image setting is display only, because it is determined by the Project > Basic Setting > Input Color Space (page 72) setting in the full menu.

**Shooting > LUT Select**

Makes settings related to the LUT to apply to the output image.

**[Note]**

The value of each menu item (excluding SDR Gain) varies depending on the Technical > Special Configuration > RM/RCP Paint Control (page 91) setting in the full menu.

Menu item	Setting	Description
SDR Gain	-15dB to 0dB ( <b>-12dB</b> ) (1 dB increments)	<p>Sets the SDR output gain when RM/RCP Paint Control is set to On. You can use this to change the gain of the Monitor or viewfinder output that is set to R709(800%) or R709-Like.</p> <p><b>[Note]</b> Configurable when Technical &gt; Special Configuration &gt; RM/RCP Paint Control (page 91) is set to On in the full menu.</p>

# Project Menu

The functions and available settings of each menu item are given below.

Default values are shown underlined and in **bold** text.

Project > <b>Basic Setting</b> Makes settings related to picture size and project frame rate.		
Menu item	Setting	Description
Imager Mode	MPC-3628 8.6K 3:2/8.2K 17:9/ 7.6K 16:9/5.8K 6:5/ <b>5.8K 17:9</b> /5.4K 16:9 MPC-3626 6K 3:2/6K 1.85:1/6K 17:9/6K 2.39:1/5.7K 16:9/4K 6:5/4K 4:3/4K 4:3 Surround View/ <b>4K 17:9</b> /4K 17:9 Surround View/4K 2.39:1/3.8K 16:9/3.8K 16:9 Surround View	Selects the effective picture size.  [Notes] • 5.8K 6:5 is displayed only when an Anamorphic License is installed. • 7.6K 16:9/8.2K 17:9/8.6K 3:2 are displayed only when a Full-Frame License is installed. • 6K 3:2/6K 1.85:1/6K 17:9/6K 2.39:1/5.7K 16:9 are displayed only when a Full-Frame License is installed. • 4K 6:5/4K 4:3/4K 4:3 Surround View are displayed only when an Anamorphic License is installed.
Project Frame Rate	<b>23.98</b> /24/25/29.97/47.95/ 50/59.94	Selects the project frame rate.
Input Color Space	When RM/RCP Paint Control (page 91) is set to Off: <b>S-Gamut3.Cine/SLog3</b> / S-Gamut3/SLog3 / ACEScct When RM/RCP Paint Control is set to On: <b>S-Gamut3.Cine/SLog3</b> / S-Gamut3/SLog3 / ACEScct / HLG(Natural) / HLG(Live) / Rec.2020/User Gamma / Rec.709/User Gamma	Sets the color space.  [Note] HLG(Natural) is equivalent to HLG BT.2100.
Recording Format	X-OCN XT/ <b>X-OCN ST</b> /X-OCN LT/ProRes 4444 4K/ProRes 4444 QFHD/ProRes 422 HQ 4K/ProRes 422 HQ QFHD	Selects the video format to be recorded on an AXS memory card.
Base ISO	MPC-3628 <b>ISO 800</b> /ISO 3200 MPC-3626 <b>ISO 500</b> /ISO 2500	Sets the base sensitivity.

## Project > **Basic Setting**

Makes settings related to picture size and project frame rate.

Menu item	Setting	Description
Anamo. De-Squeeze	<b>Off(1.0x)</b> /1.25x/1.3x/1.5x/ 1.65x/1.8x/2.0x	Sets the de-squeeze processing for ProRes recording signals and video output signals. This setting is available when an Anamorphic License is installed and Imager Mode is set to 4K 4:3/4K 4:3 Surround View/4K 6:5/4K 17:9/4K 17:9 Surround View/5.8K 6:5/5.8K 17:9, or when an Anamorphic License and Full-Frame License are installed and Imager Mode is set to 6K 3:2/6K 17:9/8.2K 17:9/8.6K 3:2. The options vary depending on the picture size.

### MPC-3628

Imager Mode	Anamo. De-Squeeze						
	Off(1.0x)	1.25x	1.3x	1.5x	1.65x	1.8x	2.0x
8.6K 3:2	Yes	Yes	Yes	Yes	Yes	Yes	Yes
8.2K 17:9	Yes	Yes	Yes	–	Yes	Yes	Yes
7.6K 16:9	Yes	–	–	–	–	–	–
5.8K 6:5	Yes	–	–	–	–	–	Yes
5.8K 17:9	Yes	Yes	Yes	–	Yes	Yes	Yes
5.4K 16:9	Yes	–	–	–	–	–	–

### MPC-3626

Imager Mode	Anamo. De-Squeeze						
	Off(1.0x)	1.25x	1.3x	1.5x	1.65x	1.8x	2.0x
6K 3:2	Yes	Yes	Yes	Yes	Yes	Yes	Yes
6K 1.85:1	Yes	–	–	–	–	–	–
6K 17:9	Yes	Yes	Yes	–	Yes	Yes	Yes
6K 2.39:1	Yes	–	–	–	–	–	–
5.7K 16:9	Yes	–	–	–	–	–	–
4K 6:5	Yes	–	–	–	–	–	Yes
4K 4:3 Surround	Yes	–	Yes	–	Yes	Yes	Yes
4K 4:3	Yes	–	Yes	–	Yes	Yes	Yes
4K 17:9 Surround	Yes	Yes	Yes	–	Yes	Yes	Yes
4K 17:9	Yes	Yes	Yes	–	Yes	Yes	Yes
4K 2.39:1	Yes	–	–	–	–	–	–
3.8K 16:9 Surround	Yes	–	–	–	–	–	–
3.8K 16:9	Yes	–	–	–	–	–	–



**Project > Basic Setting**

Makes settings related to picture size and project frame rate.

Menu item	Setting	Description
Zoom to Fit	<a href="#">Off</a> /17:9/16:9	You can set whether to cut out and magnify the display of the recording image for the viewfinder screen or Monitor output.
<p><b>[Notes]</b></p> <ul style="list-style-type: none"> <li>Configurable under the following conditions. Imager Mode: 8K 3:2/6K 3:2 Recording Format: X-OCN Anamo. De-Squeeze: Off(1.0×)</li> <li>16:9 cannot be selected when Project Frame Rate is set to 47.95.</li> <li>If the setting is changed from 17:9 or 16:9 to Off, the SDI output format returns to the default setting.</li> </ul>		

**Project > Assignable Button**

Assigns functions to assignable buttons.

*For details about assigning functions, see "User Functions Screen" (page 48).*

Menu item	Setting	Description
<1>	page 48	Assigns a function to assignable button 1.
<2>	page 48	Assigns a function to assignable button 2.
<3>	page 48	Assigns a function to assignable button 3.
<4>	page 48	Assigns a function to assignable button 4.
<VF A>	page 48	Assigns a function to assignable button A on the viewfinder (DVF-EL200).
<VF B>	page 48	Assigns a function to assignable button B on the viewfinder (DVF-EL200).
<VF C>	page 48	Assigns a function to assignable button C on the viewfinder (DVF-EL200).
<User 1>	page 48	Assigns a function to ITEM key 1.
<User 2>	page 48	Assigns a function to ITEM key 2.
<User 3>	page 48	Assigns a function to ITEM key 3.
<User 4>	page 48	Assigns a function to ITEM key 4.
<User 5>	page 48	Assigns a function to ITEM key 5.

**Project > Special Recording**

Makes settings related to picture cache recording.

Menu item	Setting	Description
Cache Rec Select	On/ <a href="#">Off</a>	Turns the picture cache recording function on/off.

**Project > Special Recording**

Makes settings related to picture cache recording.

Menu item	Setting	Description
Max Cache Rec Duration	<a href="#">2 s</a> /4 s/6 s/8 s/10 s/15 s/ 24 s/30 s	Sets the playback duration of video to cache in picture cache memory. The maximum value that can be set for an AXS memory card is given below.
<p><b>[Note]</b> When FPS is set to Variable, the actual playback duration will vary from the Max Cache Rec Duration setting.</p>		

**X-OCN recording****MPC-3628**

Imager Mode	Recording Format	Project Frame Rate						
		23.98	24	25	29.97	47.95	50	59.94
8.6K 3:2	X-OCN XT	4	4	4	2	-	-	-
	X-OCN ST	10	10	8	6	-	-	-
	X-OCN LT	15	15	15	15	-	-	-
8.2K 17:9	X-OCN XT	8	8	8	6	-	-	-
	X-OCN ST	15	15	15	10	4	4	2
	X-OCN LT	30	30	30	24	10	10	8
7.6K 16:9	X-OCN XT	8	8	8	6	-	-	-
	X-OCN ST	15	15	15	10	-	4	2
	X-OCN LT	30	30	30	24	-	10	8
5.8K 6:5	X-OCN XT	10	10	10	8	2	-	-
	X-OCN ST	15	15	15	15	8	-	-
	X-OCN LT	30	30	30	30	15	-	-
5.8K 17:9	X-OCN XT	24	24	24	15	8	8	6
	X-OCN ST	30	30	30	30	15	15	10
	X-OCN LT	30	30	30	30	30	30	24
5.4K 16:9	X-OCN XT	24	24	24	15	-	8	6
	X-OCN ST	30	30	30	30	-	15	10
	X-OCN LT	30	30	30	30	-	30	24

Project > <b>Special Recording</b> Makes settings related to picture cache recording.								
Menu item	Setting	Description						
	MPC-3626							
	Imager Mode	Recording Format	Project Frame Rate					
			23.98	24	25	29.97	47.95	50 59.94
6K 3:2	X-OCN XT		15	15	15	10	4	4 2
	X-OCN ST		24	24	24	15	10	10 6
	X-OCN LT		30	30	30	30	15	15 15
6K 1.85:1	X-OCN XT		15	15	15	15	8	6 4
	X-OCN ST		30	30	30	24	15	10 10
	X-OCN LT		30	30	30	30	30	24 15
6K 17:9	X-OCN XT		15	15	15	15	8	8 4
	X-OCN ST		30	30	30	24	15	10 10
	X-OCN LT		30	30	30	30	30	24 15
6K 2.39:1	X-OCN XT		30	30	24	15	10	10 8
	X-OCN ST		30	30	30	30	15	15 15
	X-OCN LT		30	30	30	30	30	30 30
5.7K 16:9	X-OCN XT		15	15	15	15	-	8 4
	X-OCN ST		30	30	30	24	-	10 10
	X-OCN LT		30	30	30	30	-	24 15
4K 6:5	X-OCN XT		30	30	30	24	10	10 10
	X-OCN ST		30	30	30	30	24	15 15
	X-OCN LT		30	30	30	30	30	30 30
4K 4:3	X-OCN XT		30	30	30	30	15	15 10
	X-OCN ST		30	30	30	30	24	24 15
	X-OCN LT		30	30	30	30	30	30 30
4K 4:3 Surround	X-OCN XT		30	30	30	30	-	- -
	X-OCN ST		30	30	30	30	-	- -
	X-OCN LT		30	30	30	30	-	- -
4K 17:9	X-OCN XT		30	30	30	30	24	24 15
	X-OCN ST		30	30	30	30	30	30 30
	X-OCN LT		30	30	30	30	30	30 30
4K 17:9 Surround	X-OCN XT		30	30	30	30	-	- -
	X-OCN ST		30	30	30	30	-	- -
	X-OCN LT		30	30	30	30	-	- -
4K 2.39:1	X-OCN XT		30	30	30	30	30	30 24
	X-OCN ST		30	30	30	30	30	30 30
	X-OCN LT		30	30	30	30	30	30 30
3.8K(QFHD) 16:9	X-OCN XT		30	30	30	30	-	24 15
	X-OCN ST		30	30	30	30	-	30 30
	X-OCN LT		30	30	30	30	-	30 30
3.8K(QFHD) 16:9 Surround	X-OCN XT		30	30	30	30	-	- -
	X-OCN ST		30	30	30	30	-	- -
	X-OCN LT		30	30	30	30	-	- -

Project > <b>Special Recording</b> Makes settings related to picture cache recording.								
Menu item	Setting	Description						
	<b>ProRes recording</b>							
	Recording Format	Project Frame Rate						
		23.98	24	25	29.97	47.95	50	59.94
	ProRes 4K 4444	30	30	30	30	-	15	10
	ProRes 4K 422 HQ	30	30	30	30	-	24	15
	ProRes QFHD 4444	30	30	30	30	-	15	10
	ProRes QFHD 422 HQ	30	30	30	30	-	30	24

Project > <b>All File(Cam Setup)</b> Makes settings related to All-settings files.		
Menu item	Setting	Description
Load SD Card		Load an All-settings file from an SD card.
Save SD Card		Save an All-settings file on an SD card.
File ID		Displays the file ID of the All-settings file for editing.
Format SD Card		Formats an SD card.

Project > <b>Scene File</b> Makes settings related to scene files.		
<b>[Note]</b> Scene File can be displayed and selected only when Technical > Special Configuration > RM/RCP Paint Control (page 91) is set to On in the full menu.		
Menu item	Setting	Description
Recall Internal Memory		Load a scene file from internal memory.
Store Internal Memory		Save a scene file in internal memory.
Load SD Card		Load a scene file from an SD card.
Save SD Card		Save a scene file on an SD card.
File ID		Displays the file ID of the scene file for editing.

Project > <b>User Gamma</b> Makes settings related to user gamma files.		
<b>[Note]</b> User Gamma can be displayed and selected only when Technical > Special Configuration > RM/RCP Paint Control (page 91) is set to On in the full menu.		
Menu item	Setting	Description
Current Settings		Displays the name of the current user gamma file in internal memory.

Project > **User Gamma**

Makes settings related to user gamma files.

**[Note]**

User Gamma can be displayed and selected only when Technical > Special Configuration > RM/RCP Paint Control (page 91) is set to On in the full menu.

Menu item	Setting	Description
Load SD Card		<p>Load user-defined gamma table data (user gamma file) from an SD card to internal memory.</p> <p>Save user gamma files created using RAW Viewer for use by the unit in the following directory on the SD card.</p> <p>MPC-3628: PRIVATE\SONY\PRO\CAMERA\MPC3628</p> <p>MPC-3626: PRIVATE\SONY\PRO\CAMERA\MPC3626</p>
Reset	1/2/3/4/5/All	<p>Reset the user gamma files in internal memory to initial settings.</p> <p>1 to 5: Reset individually</p> <p>All: Reset all</p>

# TC/Media Menu

The functions and available settings of each menu item are given below.

Default values are shown underlined and in **bold** text.

TC/Media > <b>Timecode</b>		
Makes settings related to timecode.		
Menu item	Setting	Description
Mode	Preset F-Run (Ext-Lk)/ <b><u>Preset R-Run</u></b> /Int Regen	Selects the timecode mode. Preset F-Run (Ext-Lk): Timecode advances continuously from specified value, in sync with external input timecode. Preset R-Run: Timecode advances from specified value only when recording. Int Regen: Timecode continues from that of the previous clip.
Manual Setting	00:00:00:00 to 23:59:59:29	Sets an arbitrary timecode value.
Reset	Run/Cancel	Resets the timecode to 00:00:00:00 (execute by selecting Run).
TC Format	DF/ <b><u>NDF</u></b>	Selects the timecode format. DF: Drop frame NDF: Non drop frame
TC Source	Internal/External	Displays the TCG sync source.
Time Data Display	<b><u>Timecode</u></b> /Duration	Selects the time data to display.
TC/Media > <b>Genlock</b>		
Makes settings related to genlock.		
Menu item	Setting	Description
Input Source	<b><u>HD SDI</u></b> /Analog	Selects the genlock input signal. HD SDI: Digital Analog: Analog
Reference Lock Type	Internal/External(HD)/ External(SD)	Displays the genlock status. Displays the signal type when genlocked. Internal: Not genlocked. External(HD): Genlocked by HD sync. External(SD): Genlocked by SD sync.
TC/Media > <b>Clip Name Format</b>		
Sets clip names. (Clip name: Camera ID + Reel Number + Shot Number + date + random string)		
Menu item	Setting	Description
Camera ID	<b><u>A</u></b> to Z	Sets the camera ID used when generating clip names.
Reel Number	<b><u>001</u></b> to 999	Sets the numeric portion of the Reel Number used when generating clip names.
Camera Position	<b><u>C</u></b> /L/R	Sets the first character portion of the Shot Number used when generating clip names.

TC/Media > <b>Format Media</b>		
Formats the media and updates the management file on the media.		
Menu item	Setting	Description
AXS Slot A	Run/Cancel	Initializes the AXS memory card in slot A (execute by selecting Run).
AXS Slot B	Run/Cancel	Initializes the AXS memory card in slot B (execute by selecting Run).
SD Card	Run/Cancel	Initializes the SD card (execute by selecting Run).

# Monitoring Menu

The functions and available settings of each menu item are given below.

Default values are shown underlined and in **bold** text.

Monitoring > <b>Output Format</b> Makes settings related to output format.		
Menu item	Setting	Description
SDI 1/2	The available settings vary according to the imager mode, project frame rate, and recording format settings.	Selects the SDI 1/2 output format. Settings vary according to the recording format (page 125).
SDI 3/4	The available settings vary depending on the SDI 1/2 setting.	Selects the SDI 3/4 output format. Settings vary according to the recording format (page 125).
Monitor	The available settings vary depending on the SDI 1/2 setting.	Selects the Monitor output format. Settings vary according to the recording format (page 130).
HDMI	The available settings vary depending on the SDI 1/2 setting.	Selects the HDMI output format. Settings vary according to the recording format (page 130).
3G SDI 1/2/3/4 Output	Level A/ <b>Level B</b>	Selects whether the 3G SDI output format is Level A or Level B.
Monitoring > <b>Output Display</b> Makes settings related to monitor display.		
Menu item	Setting	Description
Flip Image	<b>Normal</b> /Horizontal Flip/ Vertical Flip/H & V Flip	Sets the orientation of the shooting mode image. When set to Normal, the image is not flipped.  [Notes] <ul style="list-style-type: none"> <li>AXS recording images are stored unflipped.</li> <li>When Vertical Flip or H &amp; V Flip is selected, both the video and audio signals are delayed by 1 frame at the imaging frame rate due to internal processing.</li> </ul>
Audio/Video Delay	<b>Off</b> /1frame	Selects whether to enable the sync function for synchronizing the audio and video with another device that is flipping the image by delaying the video signal and audio signal. Off: No delay 1frame: Delay the video signal, audio signal, and metadata (including the timecode) by approximately 1 frame.  [Note] Fixed to 1frame when Flip Image is set to Vertical Flip or H & V Flip.

Monitoring > <b>Output Display</b> Makes settings related to monitor display.		
Menu item	Setting	Description
Monitor Magnifier Mode	<b>Toggle</b> /Press & Hold	Selects the method for turning the focus magnifier function of the Monitor output image on/off. Toggle: Toggles the magnification on/off each time you press an assignable button assigned with Monitor Focus Magnifier. Press & Hold: Turns the magnification on while you press an assignable button assigned with Monitor Focus Magnifier.
Monitor Magnifier Ratio	<b>×2.0</b> / ×4.0 / ×2.0/×4.0	Selects the focus magnification ratio for the Monitor output image.  [Notes] <ul style="list-style-type: none"> <li>Only ×2.0 can be selected when Project Frame Rate (page 72) is set to 59.94 or 50.</li> <li>×2.0/×4.0 cannot be selected when Monitor Magnifier Mode is set to Press &amp; Hold.</li> </ul>

Monitoring > <b>VF Display</b> Makes settings related to the viewfinder display.		
Menu item	Setting	Description
VF LUT  [Note] Linked to the Shooting > LUT Select > VF LUT (page 70) settings in the full menu.	When Technical > Special Configuration > RM/RCP Paint Control (page 91) is set to Off in the full menu: Log/ <a href="#">s709</a> /R709(800%)/Look  When RM/RCP Paint Control is set to On: The settings change as follows depending on the Project > Basic Setting > Input Color Space (page 72) setting in the full menu. S-Gamut3.Cine/SLog3 or S-Gamut3/SLog3: Log/ <a href="#">R709(800%)</a> HLG(Natural): HLG(Natural)/ <a href="#">R709(800%)</a> HLG(Live): HLG(Live)/ <a href="#">R709(800%)</a> Rec.2020/User Gamma: User Gamma/ <a href="#">R709-Like</a> Rec.709/User Gamma: User Gamma	Selects the LUT to apply to the viewfinder/monitor screen output image.
Overlay	<a href="#">Info. A</a> /Info. B/Rec Ind./Off	Selects the information to display superimposed on the viewfinder/monitor screen output image.
Frame Line	Frame Line A/Frame Line B/ <a href="#">Off</a>	Selects the frame lines to display superimposed on the viewfinder/monitor screen output image.
VF Magnifier Mode	<a href="#">Toggle</a> /Press & Hold	Selects the method for turning the focus magnifier function of the viewfinder on/off. Toggle: Toggles the magnification on/off each time you press an assignable button assigned with VF Focus Magnifier. Press & Hold: Turns the magnification on while you press an assignable button assigned with VF Focus Magnifier.

Monitoring > <b>VF Display</b> Makes settings related to the viewfinder display.		
Menu item	Setting	Description
VF Magnifier Ratio	<a href="#">x2.0</a> / x4.0 / x2.0/x4.0	Selects the focus magnification ratio for the viewfinder.  [Note] x2.0/x4.0 cannot be selected when VF Magnifier Mode is set to Press & Hold.
Color	-99 to <a href="#">±0</a> to +99	Adjusts the color depth of the viewfinder image.
SDR Gain	-15dB to 0dB ( <a href="#">-12dB</a> ) (1 dB increments)	Sets the SDR output gain when RM/RCP Paint Control is set to On. You can use this to change the gain of the Monitor or viewfinder output that is set to R709(800%) or R709-Like.  [Notes] • Linked to the Shooting > LUT Select > SDR Gain (page 71) settings in the full menu. • Configurable when Technical > Special Configuration > RM/RCP Paint Control (page 91) is set to On in the full menu.

Monitoring > <b>VF Function</b> Makes settings related to viewfinder functions.		
Menu item	Setting	Description
Double Speed Scan	On/ <a href="#">Off</a>	Turns the viewfinder double speed scan function on/off.
Peaking Frequency	<a href="#">Normal</a> /High	Selects whether the peaking frequency is normal or high during peaking.  [Note] The peaking level is set using the viewfinder menu.
Assign<VF A>	page 48	Assigns a function to assignable button A on the viewfinder (DVF-EL200).
Assign<VF B>	page 48	Assigns a function to assignable button B on the viewfinder (DVF-EL200).
Assign<VF C>	page 48	Assigns a function to assignable button C on the viewfinder (DVF-EL200).
Zebra	On/ <a href="#">Off</a>	Turns the zebra function on/off.
Zebra Select	<a href="#">1/2</a> /Both	Selects the zebra pattern type (Zebra 1, Zebra 2, Both).
Zebra1 Level	0% to 107% ( <a href="#">41%</a> )	Sets the display level of zebra 1.
Zebra1 Aperture Level	1% to 20% ( <a href="#">10%</a> )	Sets the aperture level of zebra 1.

Monitoring > <b>VF Function</b>		
Makes settings related to viewfinder functions.		
Menu item	Setting	Description
Zebra2 Level	0% to 109% ( <b>61%</b> )	Sets the display level of zebra 2.
Monitoring > <b>Overlays/Frame Line</b>		
Makes settings related to information and frame lines superimposed on each output signal. On/Off setting is selected using a checkbox (excluding Frame Line on Playback). On: Checkbox selected Off: Checkbox cleared		
Menu item	Setting	Description
VF	Overlay ( <b>On</b> /Off, <b>Info. A</b> /Info. B/Rec Ind.)	Selects the information to display superimposed on the viewfinder/monitor screen output image.
	Frame Line (On/ <b>Off</b> , <b>Line A</b> /Line B)	Selects the frame lines to display superimposed on the viewfinder/monitor screen output image.
SDI 1/2	Overlay ( <b>On</b> /Off, Info. A/ <b>Info. B</b> /Rec Ind.)	Selects the information to display superimposed on the SDI 1/2 output signal.
	Frame Line (On/ <b>Off</b> , Line A/ <b>Line B</b> )	Selects the frame lines to display superimposed on the SDI 1/2 output signal.
SDI 3/4	Overlay ( <b>On</b> /Off, Info. A/ <b>Info. B</b> /Rec Ind.)	Selects the information to display superimposed on the SDI 3/4 output signal.
	Frame Line (On/ <b>Off</b> , Line A/ <b>Line B</b> )	Selects the frame lines to display superimposed on the SDI 3/4 output signal.
	Same as Monitor	Selects whether the information displayed superimposed on the SDI 3/4 output signal is the same as for the Monitor output.
Monitor	Overlay ( <b>On</b> /Off, Info. A/ <b>Info. B</b> /Rec Ind.)	Selects the information to display superimposed on the Monitor output signal.
	Frame Line (On/ <b>Off</b> , Line A/ <b>Line B</b> )	Selects the frame lines to display superimposed on the Monitor output signal.
HDMI	Overlay ( <b>On</b> /Off, Info. A/Info. B/Rec Ind.)	Selects the information to display superimposed on the HDMI output signal.
	Frame Line (On/ <b>Off</b> , Line A/ <b>Line B</b> )	Selects the frame lines to display superimposed on the HDMI output signal.
	Same as SDI 1/2/3/4 / Same as SDI 1/2 / Same as Monitor	Selects whether the information displayed superimposed on the HDMI output signal is the same as for the corresponding output.

Monitoring > <b>Overlays/Frame Line</b>		
Makes settings related to information and frame lines superimposed on each output signal. On/Off setting is selected using a checkbox (excluding Frame Line on Playback). On: Checkbox selected Off: Checkbox cleared		
Menu item	Setting	Description
Overlay A/B Setup	Project Info. A ( <b>On</b> /Off) Info. B ( <b>On</b> /Off)	Selects whether to display the project information in the output information set for Overlay A and Overlay B.
	Camera ID Status Info. A ( <b>On</b> /Off) Info. B (On/ <b>Off</b> )	Selects whether to display the camera ID information in the output information set for Overlay A and Overlay B.
TC/Genlock Status	Info. A (On/ <b>Off</b> ) Info. B (On/ <b>Off</b> )	Selects whether to display the timecode external lock status and genlock status information in the output information set for Overlay A and Overlay B.
	Timecode Info. A (On/ <b>Off</b> ) Info. B (On/ <b>Off</b> )	Selects whether to display the timecode information in the output information set for Overlay A and Overlay B.
Audio Level Meter	Info. A (On/ <b>Off</b> ) Info. B (On/ <b>Off</b> )	Selects whether to display an audio level meter in the output information set for Overlay A and Overlay B.
	Look Status Info. A (On/ <b>Off</b> ) Info. B (On/ <b>Off</b> )	Selects whether to display the type of selected Look in the output information set for Overlay A and Overlay B.
Output LUT	Info. A (On/ <b>Off</b> ) Info. B (On/ <b>Off</b> )	Selects whether to display the output LUT information in the output information set for Overlay A and Overlay B.
	Rec Format/LUT Info. A ( <b>On</b> /Off) Info. B ( <b>On</b> /Off)	Selects whether to display the recording format and recording LUT information in the output information set for Overlay A and Overlay B.
VF Status	Info. A ( <b>On</b> /Off) Info. B (On/ <b>Off</b> )	Selects whether to display the viewfinder status information in the output information set for Overlay A and Overlay B.
	Roll/Tilt Value Info. A ( <b>On</b> /Off) Info. B (On/ <b>Off</b> )	Selects whether to display the spirit level information numerically in the output information set for Overlay A and Overlay B.

**[Note]**

Roll/Tilt Value is grayed out and cannot be operated when a CBK-3610XS is connected to the unit.

Monitoring > **Overlays/Frame Line**

Makes settings related to information and frame lines superimposed on each output signal.

On/Off setting is selected using a checkbox (excluding Frame Line on Playback).

On: Checkbox selected

Off: Checkbox cleared

Menu item	Setting	Description
	Level Gauge	Selects whether to display the spirit level information graphically in the output information set for Overlay A and Overlay B.
	Info. A ( <a href="#">On</a> /Off)	
	Info. B (On/ <a href="#">Off</a> )	
		<b>[Note]</b> Level Gauge is grayed out and cannot be operated when a CBK-3610XS is connected to the unit.
	Lens Status	Selects whether to display the lens information in the output information set for Overlay A and Overlay B.
	Info. A ( <a href="#">On</a> /Off)	
	Info. B ( <a href="#">On</a> /Off)	
	Option (Meter/ <a href="#">Feet</a> )	Selects the focus position display units.
	Remote Control Status	Selects whether to display the remote control status information in the output information set for Overlay A and Overlay B.
	Info. A ( <a href="#">On</a> /Off)	
	Info. B (On/ <a href="#">Off</a> )	

Monitoring > **Overlays/Frame Line**

Makes settings related to information and frame lines superimposed on each output signal.

On/Off setting is selected using a checkbox (excluding Frame Line on Playback).

On: Checkbox selected

Off: Checkbox cleared

Menu item	Setting	Description
Frame Line A/B Setup	Color	Sets the display color of frame lines.
	Option ( <a href="#">White</a> /Yellow/ Cyan/Green/Magenta/ Red/Blue)	
	Center Marker	Selects whether to display the center marker in the output information set for Frame Line A and Frame Line B.
	Line A ( <a href="#">On</a> /Off)	
	Line B ( <a href="#">On</a> /Off)	Selects the display form (Cross/Open Cross/Dot) of the center marker.
	Option ( <a href="#">Cross</a> /Open Cross/Dot)	
	Picture Area	Selects whether to display the picture area in the output information set for Frame Line A and Frame Line B.
	Line A ( <a href="#">On</a> /Off)	
	Line B ( <a href="#">On</a> /Off)	
	Aspect Ratio	Selects whether to display the aspect ratio marker in the output information set for Frame Line A and Frame Line B.
	Line A ( <a href="#">On</a> /Off)	
	Line B ( <a href="#">On</a> /Off)	Selects the mode (17:9/16:9/15:9/14:9/13:9/9:16/4:3/1:1/1.43:1/1.66:1/1.85:1/2:1/2.35:1/2.39:1) when displaying the aspect ratio marker.
	Option (17:9/ <a href="#">16:9</a> /15:9/ 14:9/13:9/9:16/4:3/1:1/ 1.43:1/1.66:1/1.85:1/2:1/ 2.35:1/2.39:1)	
	Aspect Ratio Type	Selects the display form of the aspect ratio marker.
	Option ( <a href="#">Line</a> /Mask/ Line&Mask)	
	Surround View Type	Selects the display form of the Surround View marker.
	Option ( <a href="#">Line</a> /Mask/ Line&Mask)	
		Line: Displays the recording area using lines.
		Mask: Displays the recording area by masking (reducing) the video signal level outside the recording area.
		Line&Mask: Displays the recording area using lines and by masking (reducing) the video signal level outside the recording area.
	Mask Level	Selects the brightness of the image outside the marker when Aspect Ratio Type or Surround View Type is set to Mask.
	Option (0 to 15 ( <a href="#">12</a> ))	



**Monitoring > Overlays/Frame Line**  
 Makes settings related to information and frame lines superimposed on each output signal.  
 On/Off setting is selected using a checkbox (excluding Frame Line on Playback).  
 On: Checkbox selected  
 Off: Checkbox cleared

Menu item	Setting	Description
Safety Zone	Line A (On/ <b>Off</b> ) Line B (On/ <b>Off</b> ) Option (80%/90%/92.5%/95%)	Selects whether to display the safety zone in the output information set for Frame Line A and Frame Line B. Selects the range (80%/90%/92.5%/95%) of the safety zone.
Aspect Safety Zone	Line A (On/ <b>Off</b> ) Line B (On/ <b>Off</b> ) Option (80%/90%/92.5%/95%)	Selects whether to display the aspect safety zone in the output information set for Frame Line A and Frame Line B. Selects the size (percentage of the entire screen) of the aspect safety zone marker.
User Frame Line 1	Line A (On/ <b>Off</b> ) Line B (On/ <b>Off</b> ) Option (Preset/ <b>Variable</b> )	Selects whether to display user frame line 1 in the output information set for Frame Line A and Frame Line B. Selects whether to display user frame line 1 or fixed aspect ratio.
User Frame Line 2	Line A (On/ <b>Off</b> ) Line B (On/ <b>Off</b> ) Option (Preset/ <b>Variable</b> )	Selects whether to display user frame line 2 in the output information set for Frame Line A and Frame Line B. Selects whether to display user frame line 2 or fixed aspect ratio.
Frame Line on Playback	Option ( <b>On</b> /Off)	Turns the function to superimpose frame lines during playback on/off.

**Monitoring > Frame Line Setup**  
 Makes settings related to lines and markers displayed on the output image.

Menu item	Setting	Description
Color	<b>White</b> /Yellow/Cyan/Green/ Magenta/Red/Blue	Selects the display color of frame lines.
Center Marker	<b>Cross</b> /Open Cross/Dot	Selects the display form of the center marker.
Aspect Ratio	17:9/ <b>16:9</b> /15:9/14:9/13:9/ 9:16/4:3/1:1/1.43:1/1.66:1/ 1.85:1/2:1/2.35:1/2.39:1	Selects the mode when displaying the aspect ratio marker.

**Monitoring > Frame Line Setup**  
 Makes settings related to lines and markers displayed on the output image.

Menu item	Setting	Description
Aspect Ratio Type	<b>Line</b> /Mask/Line&Mask	Selects the display form of the aspect ratio marker. Line: Displays lines with color set by Color. Mask: Displays a lower video signal level for areas outside the marker area. Line&Mask: Displays lines with color set by Color and a lower video signal level for areas outside the marker area.
Surround View Type	<b>Line</b> /Mask/Line&Mask	Selects the display form of the Surround View marker. Line: Displays the recording area using lines. Mask: Displays the recording area by masking (reducing) the video signal level outside the recording area. Line&Mask: Displays the recording area using lines and by masking (reducing) the video signal level outside the recording area.
Mask Level	0 to 15 ( <b>12</b> )	Selects the brightness of the image outside the marker when Aspect Ratio Type or Surround View Type is set to Mask.
Safety Zone	80%/90%/92.5%/95%	Selects the safety zone range.
Aspect Safety Zone	80%/90%/92.5%/95%	Selects the size (percentage of the entire screen) of the aspect safety zone marker.
Frame Line on Playback	<b>On</b> /Off	Turns the function to superimpose frame lines during playback on/off.

**Monitoring > User Frame Line 1**  
 Makes settings related to user frame line 1.

Menu item	Setting	Description
Select	Preset/ <b>Variable</b>	Selects whether to display user frame line 1 or fixed aspect ratio. Preset: Displays the aspect ratio set by Preset Aspect Ratio, Scaling, and Preset Aspect Ratio Type. Variable: Displays an arbitrary rectangular frame set by Width, Height, H Position, V Position, and Variable Aspect Type.

Monitoring > <b>User Frame Line 1</b> Makes settings related to user frame line 1.		
Menu item	Setting	Description
Preset Aspect Ratio	17:9/ <b>16:9</b> /15:9/14:9/13:9/ 9:16/4:3/1:1/1.43:1/1.66:1/ 1.85:1/2:1/2.35:1/2.39:1/ 1.90:1 (W34)* * Frame line with the same horizontal picture size as when 1.43:1 is set. In 6K 3:2 mode, the horizontal picture size is approximately 34 mm.	Selects the mode when displaying a fixed aspect ratio.  [Note] Configurable only when Select is set to Preset.
Scaling	1% to <b>100%</b> /---	Sets the scale factor for a fixed aspect ratio.  [Notes] • Configurable only when Select is set to Preset. • "----" is displayed when Preset Aspect Ratio is set to 1.90:1 (W34), and configuration is not possible.
Preset Aspect Ratio Type	<b>Line</b> /Mask/Line&Mask	Selects the display form for a fixed aspect ratio. Line: Displays using lines. Mask: Displays a lower video signal level for areas outside the marker area. Line&Mask: Displays lines and a lower video signal level for areas outside the marker area.  [Note] Configurable only when Select is set to Preset.
Aspect Ratio(Pixels)	Aspect ratio (number of pixels, anamorphic ratio)	Displays the aspect ratio of user frame line 1, number of pixels, and anamorphic ratio for the effective picture size.  [Note] The number of pixels is the value for the effective picture size before anamorphic de-squeeze conversion.
Width	3 to 480 ( <b>240</b> )	Sets the user frame line 1 width (distance from the center to the left and right edges).  [Note] Configurable only when Select is set to Variable.
Height	3 to 270 ( <b>135</b> )	Sets the user frame line 1 height (distance from the center to the top and bottom edges).  [Note] Configurable only when Select is set to Variable.

Monitoring > <b>User Frame Line 1</b> Makes settings related to user frame line 1.		
Menu item	Setting	Description
H Position	Max. -477 to 477 ( <b>±0</b> )	Sets the horizontal position of the center of user frame line 1. The setting range becomes narrower as the Width setting increases above 3.  [Note] Configurable only when Select is set to Variable.
V Position	Max. -267 to 267 ( <b>±0</b> )	Sets the vertical position of the center of user frame line 1. The setting range becomes narrower as the Height setting increases above 3.  [Note] Configurable only when Select is set to Variable.
Variable Aspect Type	Line	Displays the type of the user frame line 1 display.  [Note] Displayed only when Select is set to Variable.

Monitoring > <b>User Frame Line 2</b> Makes settings related to user frame line 2.		
Menu item	Setting	Description
Select	Preset/ <b>Variable</b>	Selects whether to display user frame line 2 or fixed aspect ratio. Preset: Displays the aspect ratio set by Preset Aspect Ratio, Scaling, and Preset Aspect Ratio Type. Variable: Displays an arbitrary rectangular frame set by Width, Height, H Position, V Position, and Variable Aspect Type.
Preset Aspect Ratio	17:9/ <b>16:9</b> /15:9/14:9/13:9/ 9:16/4:3/1:1/1.43:1/1.66:1/ 1.85:1/2:1/2.35:1/2.39:1/ 1.90:1 (W34)* * Frame line with the same horizontal picture size as when 1.43:1 is set. In 6K 3:2 mode, the horizontal picture size is approximately 34 mm.	Selects the mode when displaying a fixed aspect ratio.  [Note] Configurable only when Select is set to Preset.

Monitoring > <b>User Frame Line 2</b> Makes settings related to user frame line 2.		
Menu item	Setting	Description
Scaling	1% to <a href="#">100%</a> /---	Sets the scale factor for a fixed aspect ratio.  [Notes] <ul style="list-style-type: none"> <li>Configurable only when Select is set to Preset.</li> <li>"---" is displayed when Preset Aspect Ratio is set to 1.90:1 (W34), and configuration is not possible.</li> </ul>
Preset Aspect Ratio Type	Line	Displays the display form for a fixed aspect ratio.  [Note] Displayed only when Select is set to Preset.
Aspect Ratio(Pixels)	Aspect ratio (number of pixels, anamorphic ratio)	Displays the aspect ratio of user frame line 2, number of pixels, and anamorphic ratio for the effective picture size.  [Note] The number of pixels is the value for the effective picture size before anamorphic de-squeeze conversion.
Width	3 to 480 ( <a href="#">240</a> )	Sets the user frame line 2 width (distance from the center to the left and right edges).  [Note] Configurable only when Select is set to Variable.
Height	3 to 270 ( <a href="#">135</a> )	Sets the user frame line 2 height (distance from the center to the top and bottom edges).  [Note] Configurable only when Select is set to Variable.
H Position	Max. -477 to 477 ( <a href="#">±0</a> )	Sets the horizontal position of the center of user frame line 2. The setting range becomes narrower as the Width setting increases above 3.  [Note] Configurable only when Select is set to Variable.
V Position	Max. -267 to 267 ( <a href="#">±0</a> )	Sets the vertical position of the center of user frame line 2. The setting range becomes narrower as the Height setting increases above 3.  [Note] Configurable only when Select is set to Variable.

Monitoring > <b>User Frame Line 2</b> Makes settings related to user frame line 2.		
Menu item	Setting	Description
Variable Aspect Type	Line	Displays the type of the user frame line 2 display.  [Note] Displayed only when Select is set to Variable.

# Audio Menu

The functions and available settings of each menu item are given below.

Default values are shown underlined and in **bold** text.

Audio > <b>Audio Input</b>		
Makes settings related to audio recording levels.		
[Note] The audio recording level with AES/EBU signal selected is fixed.		
Menu item	Setting	Description
Internal Mic Select	<u>Off</u> / CH-1/CH-2 / CH-3/CH-4	Selects the input channel of the internal microphone.
XLR Audio L Select	<u>Auto</u> /Manual	Automatically adjusts the audio recording when set to Auto.
XLR Audio R Select	<u>Auto</u> /Manual	Automatically adjusts the audio recording when set to Auto.
XLR Audio L Level	-99 to <u>±0</u> to +99	Adjusts the audio recording level when CH-1 Audio Select is set to Manual.
XLR Audio R Level	-99 to <u>±0</u> to +99	Adjusts the audio recording level when CH-2 Audio Select is set to Manual.
XLR Mic Reference	-60dB/ <u>-50dB</u> /-40dB	Selects the reference input level of the microphone.

Audio > <b>Audio Monitor</b>		
Makes settings related to audio monitoring.		
Menu item	Setting	Description
Monitor CH	When Monitor Output CH Pair is set to CH-1/CH-2 <u>CH-1/CH-2</u> , CH-1, CH-2 When Monitor Output CH Pair is set to CH-3/CH-4 <u>CH-3/CH-4</u> , CH-3, CH-4	Selects the audio channel that is output to the headphones and speaker. CH-1/CH-2 (CH-3/CH-4): Channel 1+2 (Channel 3+4) CH-1 (CH-3): Channel 1 (Channel 3) only CH-2 (CH-4): Channel 2 (Channel 4) only
Monitor Level	<u>0</u> to 99	Adjusts the monitor audio level.  [Note] If configured such that the internal microphone captured sound is audible from the built-in speaker, howling may occur if the monitor volume is increased.

Audio > <b>Audio Configuration</b>		
Makes settings related to audio input/output.		
Menu item	Setting	Description
Alarm Level	<u>0</u> to 99	Adjusts the alarm audio level.
Input Limiter Mode	<u>Off</u> /-6dB/-9dB/-12dB/ -15dB/-17dB	Selects the limiter characteristic (saturation level) for large input signals when adjusting the audio input level manually. Select Off if not using the limiter.

Audio > <b>Audio Configuration</b>		
Makes settings related to audio input/output.		
Menu item	Setting	Description
AGC Level	<u>-6dB</u> /-9dB/-12dB/ -15dB/-17dB	Selects the AGC characteristic (saturation level).
AGC Mono/Stereo	Mono/ <u>Stereo</u>	Automatically adjusts the input level of analog audio signals recorded on channels 1 and 2, and selects whether to make the adjustments separately for each channel (Mono) or in stereo mode (Stereo).
MIC Input Mono/Stereo	Mono/ <u>Stereo</u>	Selects whether the front microphone is monaural (Mono) or stereo (Stereo).
Phantom Power +48V	<u>On</u> /Off	Turns the function to supply a +48 V external source (phantom power) to the microphone on/off.
Monitor Output CH Pair	<u>CH-1/CH-2</u> , CH-3/CH-4	Sets the audio output channels to either channels 1 and 2 or channels 3 and 4.
Headphone Mono/ST	<u>Mono</u> /Stereo	Sets the headphones output to monaural (Mono) or stereo (Stereo).

# Paint Menu

The functions and available settings of each menu item are given below.

## [Note]

Technical > Special Configuration > RM/RCP Paint Control (page 91) must be set to On in the full menu to enable the setting of Paint menu items.

Default values are shown underlined and in **bold** text.

Paint > <b>Black</b> Makes settings related to black level.		
Menu item	Setting	Description
Master Black	-99 to <u>±0</u> to +99	Sets the master black level.
R Black	-99 to <u>±0</u> to +99	Sets the R black level.
B Black	-99 to <u>±0</u> to +99	Sets the B black level.
Paint > <b>Flare</b> Makes settings related to flare correction.		
Menu item	Setting	Description
Setting	On/ <b>Off</b>	Turns the flare correction function on/off.
Master Flare	-99 to <u>±0</u> to +99	Sets the master flare user adjustment of the flare correction required by the unit.
R Flare	-99 to <u>±0</u> to +99	Sets the R flare user adjustment of the flare correction required by the unit.
G Flare	-99 to <u>±0</u> to +99	Sets the G flare user adjustment of the flare correction required by the unit.
B Flare	-99 to <u>±0</u> to +99	Sets the B flare user adjustment of the flare correction required by the unit.
Paint > <b>Gamma</b> Makes settings related to gamma correction.		
Menu item	Setting	Description
Setting	<b>On</b> /Off	Turns the gamma correction function on/off.
Gamma Category	S-Log3/HLG(Natural)/HLG(Live)/User	The gamma category setting is display only, because it is determined by the Project > Basic Setting > Input Color Space (page 72) setting in the full menu.

Paint > <b>Gamma</b> Makes settings related to gamma correction.		
Menu item	Setting	Description
Gamma Select	When Gamma Category is set to S-Log3: S-Log3 When Gamma Category is set to HLG(Natural): HLG(Natural) When Gamma Category is set to HLG(Live): HLG(Live) When Gamma Category is set to User: <u>User 1</u> /User 2/User 3/ User 4/User 5	Selects the gamma table used for gamma correction.
Paint > <b>Black Gamma</b> Makes settings related to black gamma correction.		
Menu item	Setting	Description
Setting	On/ <b>Off</b>	Turns the black gamma correction function on/off.
Range	Low/L.Mid/ <b>H.Mid</b>	Selects the effective range of black gamma correction. Low: 0% to 3.6% L.Mid: 0% to 7.2% H.Mid: 0% to 14.4%
Master Black Gamma	-99 to <u>±0</u> to +99	Sets the master black gamma level.
Paint > <b>Knee</b> Makes settings related to knee correction.		
Menu item	Setting	Description
Setting	On/ <b>Off</b>	Turns the knee correction function on/off.
Point	-99 to <u>±0</u> to +99	Sets the knee point.
Slope	-99 to <u>±0</u> to +99	Sets the knee slope.

**Paint > White Clip**

Makes settings related to white clip adjustment.

**[Note]**

White Clip is grayed out and cannot be operated when Project > Basic Setting > Input Color Space (page 72) is set to S-Gamut3.Cine/SLog3 or S-Gamut3/SLog3 in the full menu.

Menu item	Setting	Description
Setting	On/ <b>Off</b>	Turns the white clip adjustment function on/off.
Level	60.0% to 108.0% to <b>109.0%</b>	Sets the white clip level.

**Paint > Detail**

Makes settings related to detail adjustment.

Menu item	Setting	Description
Setting	<b>On</b> /Off	Turns the detail adjustment function on/off.
Level	-99 to <b>±0</b> to +99	Sets the detail level.
H/V Ratio	-99 to <b>±0</b> to +99	Sets the mix ratio of the H detail level and V detail level.
Crispening	-99 to <b>±0</b> to +99	Sets the crispening level.
Level Depend	<b>On</b> /Off	Turns the level dependence adjustment function on/off.
Level Depend Level	-99 to <b>±0</b> to +99	Sets the level dependence level.
Frequency	-99 to <b>±0</b> to +99	Sets the center frequency of the H detail signal (larger values give finer detail).
Knee Aperture	On/ <b>Off</b>	Turns the knee aperture correction function on/off.
Knee Aperture Level	-99 to <b>±0</b> to +99	Sets the knee aperture level.
Limit	-99 to <b>±0</b> to +99	Sets the detail limiter for both the white side and black side.
White Limit	-99 to <b>±0</b> to +99	Sets the detail limiter for the white side.
Black Limit	-99 to <b>±0</b> to +99	Sets the detail limiter for the black side.

**Paint > Matrix**

Makes settings related to matrix correction.

Menu item	Setting	Description
Setting	On/ <b>Off</b>	Turns the matrix correction function on/off.
User Matrix	On/ <b>Off</b>	Turns the user matrix correction function on/off.
User Matrix R-G	-99 to <b>±0</b> to +99	Sets matrix coefficients individually for fine adjustment of the color of the whole image.
User Matrix R-B	-99 to <b>±0</b> to +99	
User Matrix G-R	-99 to <b>±0</b> to +99	
User Matrix G-B	-99 to <b>±0</b> to +99	
User Matrix B-R	-99 to <b>±0</b> to +99	
User Matrix B-G	-99 to <b>±0</b> to +99	

**Paint > Multi Matrix**

Makes settings related to multi matrix correction.

**[Note]**

Multi Matrix is grayed out and cannot be operated when Matrix is set to Off.

Menu item	Setting	Description
Setting	On/ <b>Off</b>	Turns multi-matrix correction function on/off for setting the saturation in 16-axis hue space.
Area Indication	On/ <b>Off</b>	Turns the display of a zebra pattern in the color area of the screen targeted for multi matrix correction on/off.
Reset	Run/Cancel	Sets all [Hue] and [Saturation] values on each axis to default values (execute by selecting Run).
Axis	<b>B</b> /B+/MG-/MG/MG+/R/R+/YL-/YL/YL+/G-/G/G+/CY/CY+/B-	Sets the color targeted for multi matrix correction (16-axis mode)
Hue	-99 to <b>±0</b> to +99	Sets the hue of the color targeted for multi matrix correction for each of the 16 axes.
Saturation	-99 to <b>±0</b> to +99	Sets the saturation of the color targeted for multi matrix correction for each of the 16 axes.

# Technical Menu

The functions and available settings of each menu item are given below.

Default values are shown underlined and in **bold** text.

Technical > <b>System Configuration</b> Makes settings related to control of the unit.		
Menu item	Setting	Description
Fan Control	Auto / Max / <u>Off in Rec/Auto</u> / Off in Rec/Max	Selects the fan control mode. Auto: Controls the fan automatically in response to the internal temperature. Max: Fan rotates at maximum speed. Off in Rec/Auto: The fan is silent when recording, and operates automatically in response to the internal temperature when not recording. Off in Rec/Max: The fan is silent when recording, and rotates at maximum speed when not recording.
Shutter Mode	Speed/ <u>Angle</u>	Selects the operating mode of the electronic shutter.
SDI Rec Remote Trigger	<u>Off</u> / HD SDI Remote I/F / Parallel Rec	Selects the SDI remote / mode control method. Off: Disables remote control. HD SDI Remote I/F: Uses HD SDI Remote control method. Parallel Rec: Uses valid flag control method.
Level Gauge Adjust	Run/Cancel	Execute the zero adjustment of the spirit level gauge (execute by selecting Run).
Level Gauge Reset	Run/Cancel	Reset the zero adjustment value of the spirit level gauge (execute by selecting Run).
Technical > <b>Lens Configuration</b> Makes settings related to lenses.		
Menu item	Setting	Description
PL-Mt Interface Position	<u>Top</u> /Side/Off	Sets the interface position of the PL-mount lens.  [Note] Set before attaching a lens, according to the lens to attach. If changing this setting while the lens is attached to the unit, reboot the unit.
PL-Mt Voltage	<u>8 V</u> → 24 V/24 V	Sets the powering method of the PL-mount lens.
Focus Distance Format	Meter/ <u>Feet</u>	Selects the focus position display units.
Lens 12pin	<u>On</u> /Off	Turns the 12-pin lens interface on/off.  [Note] If changing this setting while the lens is attached to the unit, reboot the unit.

Technical > <b>Lens Configuration</b> Makes settings related to lenses.		
Menu item	Setting	Description
E-Mount Shading Comp.	<u>Auto</u> /Off	Sets whether to compensate for a drop in peripheral lighting when a compatible lens is attached.
E-Mt Chro. Aber. Comp.	<u>Auto</u> /Off	Sets whether to compensate for chromatic aberration in peripheral lighting when a compatible lens is attached.
Technical > <b>Auto Pixel Restore</b> Executes Auto Pixel Restoration (auto adjustment of the image sensor).		
Menu item	Setting	Description
Auto Pixel Restoration	Run/Cancel	Executes the automatic pixel noise reduction function (execute by selecting Run).
Reset	Run/Cancel	Deletes white flecks added by execution of the APR function (execute by selecting Run).
Technical > <b>Authentication</b> Makes basic settings related to network authentication.		
Menu item	Setting	Description
User Name	(Displays the current user name.)	Sets the user name to use for access authentication. Set to "admin" by factory default.
Password	(*****)	Sets the password to use for access authentication (8 or more alphanumeric characters containing at least one alphabetic and one numeric character). When entering a password, the asterisk characters displayed are replaced by the entered characters while the sub display ITEM key 1 is pressed.
Technical > <b>Network</b> Makes settings related to the network.		
Menu item	Setting	Description
Setting	LAN/Wireless/ <u>Off</u>	Sets the network connection method.  [Note] Grayed out and cannot be changed if a password is not configured using Technical > Authentication > Password (page 87) in the full menu.

Technical > <b>Network</b> Makes settings related to the network.		
Menu item	Setting	Description
LAN	DHCP ( <u>On</u> /Off)	Sets DHCP. When set to On, an IP address is automatically assigned to the unit. To enter the IP address of the unit manually, set to Off.
	IP Address (DHCP/On: <u>obtain automatically</u> , DHCP/Off: <u>192.168.2.50</u> )	Enter the IP address of the unit. Enabled when DHCP is set to Off.
	Subnet Mask (DHCP/On: <u>obtain automatically</u> , DHCP/Off: <u>255.255.255.0</u> )	Enter the subnet mask of the unit. Enabled when DHCP is set to Off.
Wireless	Network Mode ( <u>Access Point</u> /Station)	Sets the network mode for wireless connections.
	Scan Networks (Run/Cancel)	Scans for access points for connection destinations (execute by selecting Run).  [Note] Configurable only when Network Mode is set to Station.
	SSID	When Network Mode is set to Access Point Displays the SSID for the wireless connection to the unit. When Network Mode is set to Station Displays/configures the SSID of the connection destination access point.  [Note] Valid characters for display and entry: Alphabetic (A to Z, a to z) Numeric (0 to 9 -. @ _ _ ( ) ) Symbols (! " # \$ % & ' * + , / ; : < = > ? [ \ ] ^ ` {   } ~ -)

Technical > <b>Network</b> Makes settings related to the network.		
Menu item	Setting	Description
	Password	When Network Mode is set to Access Point Displays the password for wireless connection to the unit. When Network Mode is set to Station Configures the password of the connection destination access point. When entering a password, the asterisk characters displayed are replaced by the entered characters while the sub display ITEM key 1 is pressed.  [Note] Valid characters for display and entry: Alphabetic (A to Z, a to z) Numeric (0 to 9 -. @ _ _ ( ) ) Symbols (! " # \$ % & ' * + , / ; : < = > ? [ \ ] ^ ` {   } ~ -)
	WPS (Run/Cancel)	Starts connection setup using WPS (execute by selecting Run).
	Channel (Auto(5GHz)/ <u>Auto</u> /CH1/CH2/CH3/CH4/CH5/CH6/CH7/CH8/CH9/CH10/CH11)	Sets the channel of the access point.  [Notes] <ul style="list-style-type: none"> <li>Configurable only when Network Mode is set to Access Point.</li> <li>Auto(5GHz) may not be displayed, depending on the wireless LAN module being used. Check whether use of the wireless LAN module is supported in your country/region. For details, refer to the operating instructions of the wireless LAN module.</li> </ul>
	DHCP ( <u>On</u> /Off)	Sets DHCP. When set to On, an IP address is automatically assigned to the unit. To enter the IP address of the unit manually, set to Off.  [Note] Configurable only when Network Mode is set to Station.
	IP Address (DHCP/On: <u>obtain automatically</u> , DHCP/Off: <u>192.168.1.50</u> )	Enter the IP address of the unit. Enabled when DHCP is set to Off.  [Note] Configurable only when Network Mode is set to Station.



Technical > <b>Network</b> Makes settings related to the network.		
Menu item	Setting	Description
	Subnet Mask (DHCP/On: <a href="#">obtain automatically</a> , DHCP/Off: <a href="#">255.255.255.0</a> )	Enter the subnet mask of the unit. Enabled when DHCP is set to Off.  [Note] Configurable only when Network Mode is set to Station.
	MAC Address	Displays the MAC address of the wireless LAN adaptor connected to the unit.
	Regenerate Password (Run/Cancel)	Regenerates the password (execute by selecting Run).  [Note] Executable only when Network Mode is set to Access Point.

Technical > <b>Alerts &amp; Tally</b> Makes settings related to the REC button and media capacity alerts.		
Menu item	Setting	Description
Rec Light	<a href="#">On</a> /Off	Turns the REC lamp on/off.
Rec Start/Stop Beep	<a href="#">0</a> to 99	Adjusts the volume of the beep sound emitted when recording starts and stops.
Media Near Full Alarm	1min/3min/ <a href="#">5min</a>	Sets the alarm threshold for notification that the remaining media is low.

Technical > <b>Batt./Voltage Alarm</b> Makes settings related to batteries and external DC power supply voltage alarms.		
Menu item	Setting	Description
Near End:Info Battery	<a href="#">5%</a> to 100% (5% increments)	Sets the threshold value at which the remaining battery capacity indicator starts flashing when using a Sony Info battery.
End:Info Battery	<a href="#">0%</a> to 5%	Sets the threshold value for displaying the "Battery End" warning when using a Sony Info battery.
Near End:Sony Battery	<a href="#">11.5V</a> to 17V (0.1V increments)	Sets the threshold value at which the remaining battery capacity indicator starts flashing when using a Sony non-Info battery.
End:Sony Battery	<a href="#">11.0V</a> to 12.5V (0.1V increments)	Sets the threshold value for displaying the "Battery End" warning when using a Sony non-Info battery.
Near End:Other Battery	11.5V to 17V ( <a href="#">11.8V</a> ) (0.1V increments)	Sets the threshold value at which the remaining battery capacity indicator starts flashing when using a non-Sony battery.

Technical > <b>Batt./Voltage Alarm</b> Makes settings related to batteries and external DC power supply voltage alarms.		
Menu item	Setting	Description
End:Other Battery	<a href="#">11.0V</a> to 14V (0.1V increments)	Sets the threshold value for displaying the "Battery End" warning when using a non-Sony battery.
Detected Battery	Sony Info Battery/Sony Battery/Other Battery/DC IN (12V)/DC IN (24V)	Displays the result of automatic battery pack type detection.
DC Low Voltage1	<a href="#">11.5V</a> to 17V (0.1V increments)	Sets the threshold value for displaying a low voltage warning when using an external power source connected to the DC IN connector.
DC Low Voltage2	<a href="#">11.0V</a> to 14V (0.1V increments)	Sets the threshold value for displaying an undervoltage warning when using an external power source connected to the DC IN connector.
DC(24V) Low Voltage1	<a href="#">22.5V</a> to 34.0V (0.1V increments)	Sets the threshold value for displaying a low voltage warning when using a 24 V external power source connected to the DC IN connector.
DC(24V) Low Voltage2	<a href="#">22.0V</a> to 28.0V (0.1V increments)	Sets the threshold value for displaying an undervoltage warning when using a 24 V external power source connected to the DC IN connector.

Technical > <b>Panel Control</b> Makes settings related to the displays.		
Menu item	Setting	Description
Brightness level	<a href="#">High</a> /Mid/Low/Minimum	Adjusts the brightness of the sub display and mini display.
Lock Operator Side	<a href="#">without Rec Button</a> / without Assign3 Button / without Rec/Assign3 / with Rec/Assign3 Button	Sets whether to lock the REC button or Assign3 button operation when buttons are locked using the LOCK switch on the Operator side.
Lock Assistant Side	<a href="#">without Rec Button</a> / with Rec Button	Sets whether to lock the REC button operation when buttons are locked using the LOCK switch on the Assistant side.

**Technical > False Color**

Makes settings related to false colors.

**[Note]**

False Color is grayed out and the setting cannot be changed when Technical > Special Configuration > RM/RCP Paint Control (page 91) is set to On in the full menu.

Menu item	Setting	Description
Level	<u>Preset</u> /Manual	Sets whether to use the preset on/off setting and threshold of each false color in the viewfinder/monitor output or to set colors manually. When Manual is selected, the following items can be configured.
Red	<u>On</u> /Off	Turns the display of red on/off.
Red Upper Limit	0.0% to 109.0% ( <u>96.1%</u> ) (0.1% increments)	Sets the upper limit for display in red.
Red Lower Limit	0.0% to 109.0% ( <u>93.4%</u> ) (0.1% increments)	Sets the lower limit for display in red.
Yellow	<u>On</u> /Off	Turns the display of yellow on/off.
Yellow Upper Limit	0.0% to 109.0% ( <u>93.4%</u> ) (0.1% increments)	Sets the upper limit for display in yellow.
Yellow Lower Limit	0.0% to 109.0% ( <u>91.3%</u> ) (0.1% increments)	Sets the lower limit for display in yellow.
Orange	<u>On</u> /Off	Turns the display of orange on/off.
Orange Upper Limit	0.0% to 109.0% ( <u>90.6%</u> ) (0.1% increments)	Sets the upper limit for display in orange.
Orange Lower Limit	0.0% to 109.0% ( <u>87.7%</u> ) (0.1% increments)	Sets the lower limit for display in orange.
Pink	<u>On</u> /Off	Turns the display of pink on/off.
Pink Upper Limit	0.0% to 109.0% ( <u>58.0%</u> ) (0.1% increments)	Sets the upper limit for display in pink.
Pink Lower Limit	0.0% to 109.0% ( <u>54.3%</u> ) (0.1% increments)	Sets the lower limit for display in pink.
Light Pink	<u>On</u> /Off	Turns the display of light pink on/off.
Light Pink Upper Limit	0.0% to 109.0% ( <u>50.8%</u> ) (0.1% increments)	Sets the upper limit for display in light pink.
Light Pink Lower Limit	0.0% to 109.0% ( <u>47.8%</u> ) (0.1% increments)	Sets the lower limit for display in light pink.
Cyan	<u>On</u> /Off	Turns the display of cyan on/off.
Cyan Upper Limit	0.0% to 109.0% ( <u>46.5%</u> ) (0.1% increments)	Sets the upper limit for display in cyan.
Cyan Lower Limit	0.0% to 109.0% ( <u>43.8%</u> ) (0.1% increments)	Sets the lower limit for display in cyan.

**Technical > False Color**

Makes settings related to false colors.

**[Note]**

False Color is grayed out and the setting cannot be changed when Technical > Special Configuration > RM/RCP Paint Control (page 91) is set to On in the full menu.

Menu item	Setting	Description
Green	<u>On</u> /Off	Turns the display of green on/off.
Green Upper Limit	0.0% to 109.0% ( <u>42.2%</u> ) (0.1% increments)	Sets the upper limit for display in green.
Green Lower Limit	0.0% to 109.0% ( <u>38.9%</u> ) (0.1% increments)	Sets the lower limit for display in green.
Light Blue	<u>On</u> /Off	Turns the display of light blue on/off.
Light Blue Upper Limit	0.0% to 109.0% ( <u>34.4%</u> ) (0.1% increments)	Sets the upper limit for display in light blue.
Light Blue Lower Limit	0.0% to 109.0% ( <u>24.6%</u> ) (0.1% increments)	Sets the lower limit for display in light blue.
Blue	<u>On</u> /Off	Turns the display of blue on/off.
Blue Upper Limit	0.0% to 109.0% ( <u>5.6%</u> ) (0.1% increments)	Sets the upper limit for display in blue.
Blue Lower Limit	0.0% to 109.0% ( <u>3.5%</u> ) (0.1% increments)	Sets the lower limit for display in blue.
Purple	<u>On</u> /Off	Turns the display of purple on/off.
Purple Upper Limit	0.0% to 109.0% ( <u>3.5%</u> ) (0.1% increments)	Sets the upper limit for display in purple.
Purple Lower Limit	-7.3% to 109.0% ( <u>-7.3%</u> ) (0.1% increments)	Sets the lower limit for display in purple.
Reset	Run/Cancel	Resets the on/off setting and threshold of each color (execute by selecting Run).

**Technical > Test Signals**

Makes settings related to color bars.

Menu item	Setting	Description
Color Bars	<u>On</u> /Off	Turns color bars on/off.
		<b>[Notes]</b>
		<ul style="list-style-type: none"> <li>When an RM-B170 or other remote control unit is connected, the setting from the remote control unit is displayed and grayed out.</li> <li>Color bars are not recorded, even when turned on. The captured image is recorded.</li> </ul>
Color Bar Type	<u>ARIB</u> /SMPTE	Selects the type of color bars.
1kHz Tone on Color Bars	<u>On</u> /Off	Turns the function to output a 1 kHz test signal in color bars mode on/off.
Test Saw	<u>On</u> /Off	Turns the test signal on/off.

Technical > <b>Test Signals</b> Makes settings related to color bars.		
Menu item	Setting	Description
Test Saw Type	<a href="#">Saw</a> /Step Saw	Selects the type of test signal. Saw: Output a saw wave as the test signal. Step Saw: Output a step wave as the test signal.
Technical > <b>Special Configuration</b> Makes settings related to control of the unit.		
Menu item	Setting	Description
RM/RCP Paint Control	On/ <a href="#">Off</a>	Turns the paint functions of an RM-B170 or other remote control unit on/off.  [Note] All settings on the unit are initialized when the RM/RCP Paint Control setting is changed. However, RM/RCP Paint Control and some other settings, such as network settings, are not initialized.
NR(4K 17:9/16:9)	On/ <a href="#">Off</a>	Turns the 4K 17:9/16:9 recording image noise reduction on/off.  [Note] Set to Off (fixed) when the following functions are enabled. <ul style="list-style-type: none"> <li>• Select FPS</li> <li>• Anamo. De-Squeeze: Settings other than Off(1.0×)</li> <li>• Flip Image: Settings other than Normal</li> </ul>
SD HDMI	On/ <a href="#">Off</a>	Turns the function to set the HDMI output signal to SD format on/off.  [Note] Can be set to On when all the following conditions are satisfied. Imager Mode: 16:9 (including when Zoom to Fit is set to 16:9) Recording Format: X-OCN ST Project Frame Rate: 50 or 59.94
360° Shutter Setting	<a href="#">Pre Shutter On</a> /Pre Shutter Off	Turns the pre-shutter function on/off when using 360° shutter angle (shutter off). Pre Shutter On: Turn pre-shutter on. Pre Shutter Off: Turn pre-shutter off.  [Note] When set to Pre Shutter Off, an afterimage may remain for one frame when an excessive amount of light is incident, such as when shooting with a flash.

# Maintenance Menu

The functions and available settings of each menu item are given below.

Default values are shown underlined and in **bold** text.

Maintenance > <b>Language</b>		
Selects the display language for menus and messages.		
Menu item	Setting	Description
Select	English/ <u>中文 (簡)</u>	Selects the display language for the full menu and messages.

Maintenance > <b>Clock Set</b>		
Makes settings related to the built-in clock.		
Menu item	Setting	Description
Time Zone	UTC + 14:00 to <u>UTC Greenwich</u> to UTC - 12:00 (30-minute increments)	Selects the difference in time from UTC (Greenwich Mean Time) in increments of 30 minutes.
Date Mode	<u>YYMMDD</u> /MMDDYY/DDMMYY	Selects the display format for dates. YYMMDD: Year, month, day MMDDYY: Month, day, year DDMMYY: Day, month, year
Date		Sets the current date (apply by pressing Set).
Time		Sets the current time (apply by pressing Set).

Maintenance > <b>Hours Meter</b>		
Displays the accumulated usage time.		
Menu item	Setting	Description
Hours (System)		Displays the accumulated time of use of the unit (cannot be reset).
Hours (Resettable)		Displays the accumulated time of use of the unit (can be reset).
Reset	Run/Cancel	Resets the Hours (Resettable) display to 0 (execute by selecting Run).

Maintenance > <b>Reset to Default</b>		
Returns the unit to factory default state.		
Menu item	Setting	Description
Reset	Run/Cancel	Initializes all unit settings (execute by selecting Run).

Maintenance > <b>Network Reset</b>		
Returns the network-related settings to factory default state.		
Menu item	Setting	Description
Reset	Run/Cancel	Initializes all network-related settings (execute by selecting Run).

Maintenance > <b>License Options</b>		
Installs software options.		
Menu item	Setting	Description
Install: <target_license>	Run/Cancel	Installs software options (execute by selecting Run).
Anamorphic	XX days Remaining (Y keys)/ Permanent License Installed/ Not Installed/Expired	Displays whether the Anamorphic option is enabled. XX days Remaining (Y keys): Expiration of timed license Permanent License Installed: Permanent license is installed Not Installed: Not installed Expired: Timed license has expired
Full-Frame	XX days Remaining (Y keys)/ Permanent License Installed/ Not Installed/Expired	Displays whether the full-frame option is enabled. XX days Remaining (Y keys): Expiration of timed license Permanent License Installed: Permanent license is installed Not Installed: Not installed Expired: Timed license has expired
Unique Device ID		Displays the ID used for issuing the software option license key.

Maintenance > <b>Firmware</b>		
Displays the version of the unit and updates the firmware of the unit.		
Menu item	Setting	Description
Version		Displays the firmware version of the unit (Vx.xx).
Firmware Update	Run/Cancel	Updates the unit (execute by selecting Run).

# Clip Operations on the Sub Display

Clip operations are performed using the clip list screen and the playback screen. You can play a clip by selecting the clip to play from the clip list screen displayed on the sub display.

## Clip List Screen

Press the CLIPS button (page 11) on the Assistant side to display the clip list screen for playable media on the sub display.

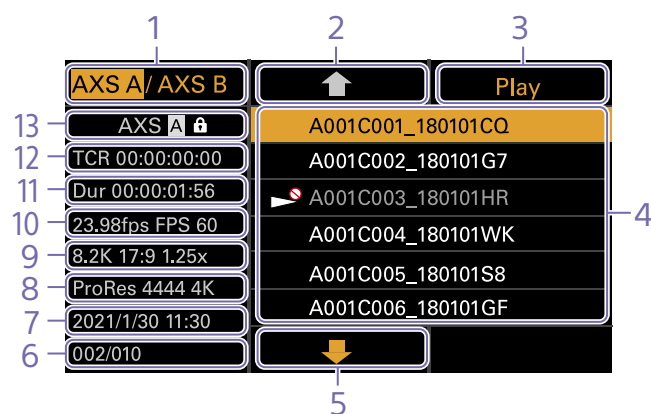

### 1. Media select button

Press ITEM key 1 to switch the media slot for playback.

### 2. Cursor up button

Press ITEM key 2 to select the clip to play from the clip list.

### 3. Playback start button

Press ITEM key 3 to display the playback screen (page 16) and start playback.

### 4. Clip list

Displays a list of clips on the active playback media. It also displays the clips status using icons.

Icon	Meaning
 (Non-playable)	Clip cannot be played

### 5. Cursor down button

Press ITEM key 5 to select the clip to play from the clip list.

### 6. Clip position in playback media

Displays the number of the clip indicated by the cursor and total number of clips.

### 7. Creation date and time

Displays the creation date and time of the clip indicated by the cursor.

### 8. Format (codec)

Displays the recording format (codec) of the clip indicated by the cursor.

### 9. Picture size indicator

Displays the effective picture size when the clip indicated by the cursor was recorded.

### 10. Project frame rate/special recording mode indicator

Displays the project frame rate and special recording mode of the clip indicated by the cursor.

### 11. Duration (Dur)

Displays the duration of the clip indicated by the cursor.

### 12. Timecode (TCR)

Displays the timecode of the first frame of the clip indicated by the cursor.

### 13. Active playback media

Displays the active playback media of the displayed list. Displays the media status using icons.

Icon	Meaning
 (protect)	Write-protected media

## Playback Screen

The playback screen is displayed when you select a clip to play on the clip list screen and press the MENU dial or Play button (ITEM key 3).

### Function display area



#### 1. F Rev button

Play back at high speed in the reverse direction.

#### 2. Play/Pause button

Play a clip or pause playback.

#### 3. F Fwd button

Play back at high speed in the forward direction.

#### 4. Prev button

Skip to the start of the previous clip.

#### 5. Stop/Clips button

Stop playback and return to the clip list screen.

#### 6. Next button

Skip to the start of the next clip.

### Status display area

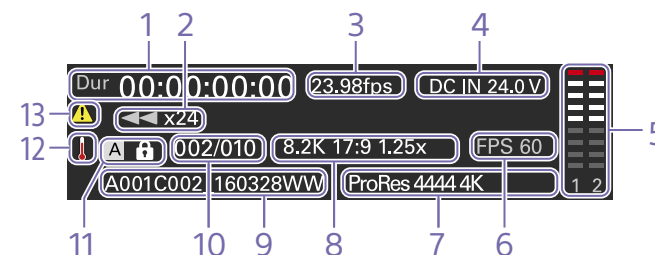

#### 1. Time data display

Displays the timecode of the playback position.

#### 2. Playback status indicator

Displays the playback status. Displays "CALL" when a CALL command is received.

#### 3. Frame rate indicator

Displays the project frame rate.

#### 4. Power supply voltage/Remaining battery capacity indicator

Displays the power supply voltage or remaining battery capacity.

#### 5. Audio level meters

Displays the playback audio level.

#### 6. Special recording mode indicator

Displays the special recording mode information of the playback clip.

#### 7. Playback clip format (codec) indicator

Displays the format (codec) of the playback clip.

#### 8. Imager mode indicator

Displays the picture size.

#### 9. Clip name indicator

Displays the name of the clip.

#### 10. Clip number

Displays the Current playback clip number/ Total number of playable clips.

#### 11. Media indicator

Displays the media being played. A (protect) icon appears on the right if the memory card is write-protected.

#### 12. Thermometer icon

Displayed when a high temperature warning message is issued. The description is displayed in the Info category in the menu.

#### 13. Warning icon

Displayed when other than a high temperature warning message is issued. The description is displayed in the Info category in the menu.

# Playback

You can play recorded clips while the unit is in standby mode.

## [Notes]

- When playing a clip recorded in ProRes, the LUT configured using LUT Select (page 68) in the Shooting menu is not applied.
- The playback controls appear on ITEM keys 1 to 6 (page 10). Press an ITEM key to select the corresponding item.

- 1 Insert the AXS memory card to play.
- 2 Press the CLIPS button (page 11) on the Assistant side.  
The clip list on the active playback media appears on the sub display.
- 3 Use the **↑** button (ITEM key 2), **↓** button (ITEM key 5), or MENU dial to select a clip to play.
- 4 Press the MENU dial or the Play button (ITEM key 3).  
The playback image appears on the viewfinder/monitor screen.



## Playback operations

Playback operation is performed using the buttons on the sub display (page 94).

Play/Pause button: Pause playback. To resume playback, press this button again.

F Fwd button/F Rev button: Fast forward/reverse. To return to normal playback, press the Play/Pause button.

Stop/Clips button: Stop playback and return to the clip list screen.

## Monitoring audio

In normal playback mode, you can monitor the recorded audio through the built-in speaker (page 9) or connected headphones.

When headphones are connected to the headphones connector (page 9), the built-in speaker is turned off.

You can select the channel to monitor and adjust the volume using Audio category > Monitor CH and Monitor Level (page 57) in the menu.

## Cueing up

To play from the start of a clip, press the Prev button on the sub display (page 94).

You can skip clips and cue-up another clip by pressing the Prev button or Next button repeatedly.

## Switching between AXS memory cards

When two AXS memory cards are loaded, press the SLOT SELECT button (page 9) to switch memory cards. When the clip list screen is displayed on the sub display, you can also press ITEM key 1 on the sub display to switch.

## [Note]

You cannot switch AXS memory cards during playback. Continuous playback of cards in slots A and B is not possible.

# Operations on the Home Screen of the Mini Display

You can check the status of the unit and set basic settings for the unit on the Home screen of the mini display.

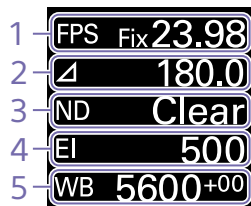

## 1. FPS

Sets the shooting frame rate.

## 2. Shutter

Displays and sets the shutter speed/shutter angle of the electronic shutter.

## 3. ND Filter

Displays and sets the density of the ND filter.

## 4. Exposure Index/Gain

Displays and sets the exposure index (EI), or displays and sets the gain value (dB units) set by an RM-B170 or other remote control unit.

### [Note]

The gain value is displayed only when Technical > Special Configuration > RM/RCP Paint Control (page 91) is set to On in the full menu.

## 5. WB (White Balance)

Displays and sets the white balance.

## Display and operation when RM/RCP Paint Control is enabled

- The gain value is displayed instead of the Exposure Index when Technical > Special Configuration > RM/RCP Paint Control (page 91) is set to On in the full menu. In this mode, the EI value cannot be changed, but the gain value can be changed.
- The following items cannot be operated when an RM-B170 or other remote control unit is connected and Technical > Special Configuration > RM/RCP Paint Control (page 91) is set to On in the full menu. Set these using the remote control unit (page 116).
  - Shutter
  - WB (White Balance)

## Controls

### HOME button (page 9)

Press to return to the Home screen. Unconfirmed changes are canceled.

### ITEM key 1 (↑ (up)) (page 9)

Press to select items on the Home screen.

### ITEM key 2 (● (apply)) (page 9)

Press to apply the selected item.

### ITEM key 3 (↓ (down)) (page 9)

Press to select items on the Home screen.

## Basic Operation

- Press ITEM key 1, 2, or 3. The cursor appears.

- Select the item to set using the ↑ button (ITEM key 1) or ↓ button (ITEM key 3).

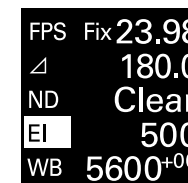

- Press the ● (apply) button (ITEM key 2). The setting value selection screen appears for the selected item.

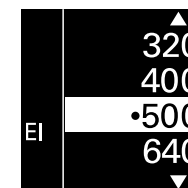

### [Note]

The ● (bullet) mark indicates the current setting.

- Move the cursor to the item or setting value using the ↑ button (ITEM key 1) or ↓ button (ITEM key 3).
- Press the ● (apply) button (ITEM key 2) to apply the setting.
- Press the HOME button to hide the cursor.



## Home Screen Items on the Mini Display

The names of items and corresponding setting values are given below.  
Default values are shown underlined and in **bold** text.

Item	Description																
FPS	Sets the shooting frame rate. Variable/Fixed: Switch between variable speed and constant speed shooting on the Home screen (page 44) of the sub display. When "Fixed" is selected, the setting is determined by the Project category > Project Frame Rate (page 54) setting in the menu.																
	<table border="1"> <thead> <tr> <th>Project Frame Rate</th> <th>Display</th> </tr> </thead> <tbody> <tr> <td>23.98</td> <td>Fix 23.98</td> </tr> <tr> <td>24</td> <td>Fix 24.00</td> </tr> <tr> <td>25</td> <td>Fix 25.00</td> </tr> <tr> <td>29.97</td> <td>Fix 29.97</td> </tr> <tr> <td>47.95</td> <td>Fix 47.95</td> </tr> <tr> <td>50</td> <td>Fix 50.00</td> </tr> <tr> <td>59.94</td> <td>Fix 59.94</td> </tr> </tbody> </table>	Project Frame Rate	Display	23.98	Fix 23.98	24	Fix 24.00	25	Fix 25.00	29.97	Fix 29.97	47.95	Fix 47.95	50	Fix 50.00	59.94	Fix 59.94
Project Frame Rate	Display																
23.98	Fix 23.98																
24	Fix 24.00																
25	Fix 25.00																
29.97	Fix 29.97																
47.95	Fix 47.95																
50	Fix 50.00																
59.94	Fix 59.94																

When "Variable" is selected, the settings change as follows depending on the Project category > Imager Mode (page 72) and Recording Format (page 72) settings in the menu.

### X-OCN recording

MPC-3628

Imager Mode	Shooting frame rate
8.6K 3:2	1 to 30 FPS
8.2K 17:9 7.6K 16:9	1 to 60 FPS
5.8K 6:5	1 to 48 FPS
5.8K 17:9	1 to 60, 66, 72, 75, 88, 90 FPS
5.4K 16:9	

Item	Description																				
	MPC-3626																				
	<table border="1"> <thead> <tr> <th>Imager Mode</th> <th>Setting</th> </tr> </thead> <tbody> <tr> <td>6K 3:2</td> <td>1 to 60 FPS</td> </tr> <tr> <td>6K 1.85:1 6K 17:9 5.7K 16:9</td> <td>1 to 60, 66, 72 FPS</td> </tr> <tr> <td>6K 2.39:1</td> <td>1 to 60, 66, 72, 75, 88, 90 FPS</td> </tr> <tr> <td>4K 6:5</td> <td>1 to 60, 66, 72 FPS</td> </tr> <tr> <td>4K 4:3</td> <td>1 to 60, 66, 72, 75 FPS</td> </tr> <tr> <td>4K 4:3 Surround View</td> <td>1 to 30 FPS</td> </tr> <tr> <td>4K 17:9 3.8K 16:9</td> <td>1 to 60, 66, 72, 75, 88, 90, 96, 100, 110 FPS</td> </tr> <tr> <td>4K 17:9 Surround View 3.8K 16:9 Surround View</td> <td>1 to 48 FPS</td> </tr> <tr> <td>4K 2.39:1</td> <td>1 to 60, 66, 72, 75, 88, 90, 96, 100, 110, 120 FPS</td> </tr> </tbody> </table>	Imager Mode	Setting	6K 3:2	1 to 60 FPS	6K 1.85:1 6K 17:9 5.7K 16:9	1 to 60, 66, 72 FPS	6K 2.39:1	1 to 60, 66, 72, 75, 88, 90 FPS	4K 6:5	1 to 60, 66, 72 FPS	4K 4:3	1 to 60, 66, 72, 75 FPS	4K 4:3 Surround View	1 to 30 FPS	4K 17:9 3.8K 16:9	1 to 60, 66, 72, 75, 88, 90, 96, 100, 110 FPS	4K 17:9 Surround View 3.8K 16:9 Surround View	1 to 48 FPS	4K 2.39:1	1 to 60, 66, 72, 75, 88, 90, 96, 100, 110, 120 FPS
Imager Mode	Setting																				
6K 3:2	1 to 60 FPS																				
6K 1.85:1 6K 17:9 5.7K 16:9	1 to 60, 66, 72 FPS																				
6K 2.39:1	1 to 60, 66, 72, 75, 88, 90 FPS																				
4K 6:5	1 to 60, 66, 72 FPS																				
4K 4:3	1 to 60, 66, 72, 75 FPS																				
4K 4:3 Surround View	1 to 30 FPS																				
4K 17:9 3.8K 16:9	1 to 60, 66, 72, 75, 88, 90, 96, 100, 110 FPS																				
4K 17:9 Surround View 3.8K 16:9 Surround View	1 to 48 FPS																				
4K 2.39:1	1 to 60, 66, 72, 75, 88, 90, 96, 100, 110, 120 FPS																				
	<b>ProRes recording</b>																				
	MPC-3628																				
	<table border="1"> <thead> <tr> <th rowspan="2">Imager Mode</th> <th colspan="2">Shooting frame rate</th> </tr> <tr> <th colspan="2">ProRes 4K / QFHD</th> </tr> <tr> <td></td> <th>4444</th> <th>422 HQ</th> </tr> </thead> <tbody> <tr> <td>8.2K 17:9 7.6K 16:9</td> <td>1 to 60 FPS</td> <td>1 to 60 FPS</td> </tr> <tr> <td>5.8K 6:5</td> <td>1 to 48 FPS</td> <td>1 to 48 FPS</td> </tr> <tr> <td>5.8K 17:9</td> <td>1 to 60 FPS</td> <td>1 to 60, 66, 72, 75 FPS</td> </tr> <tr> <td>5.4K 16:9</td> <td></td> <td></td> </tr> </tbody> </table>	Imager Mode	Shooting frame rate		ProRes 4K / QFHD			4444	422 HQ	8.2K 17:9 7.6K 16:9	1 to 60 FPS	1 to 60 FPS	5.8K 6:5	1 to 48 FPS	1 to 48 FPS	5.8K 17:9	1 to 60 FPS	1 to 60, 66, 72, 75 FPS	5.4K 16:9		
Imager Mode	Shooting frame rate																				
	ProRes 4K / QFHD																				
	4444	422 HQ																			
8.2K 17:9 7.6K 16:9	1 to 60 FPS	1 to 60 FPS																			
5.8K 6:5	1 to 48 FPS	1 to 48 FPS																			
5.8K 17:9	1 to 60 FPS	1 to 60, 66, 72, 75 FPS																			
5.4K 16:9																					

Item	Description																																			
	MPC-3626																																			
	<table border="1"> <thead> <tr> <th rowspan="2">Imager Mode</th> <th colspan="2">Shooting frame rate</th> </tr> <tr> <th colspan="2">ProRes 4K / QFHD</th> </tr> </thead> <tbody> <tr> <td></td> <td>4444</td> <td>422 HQ</td> </tr> <tr> <td>6K 17:9</td> <td>1 to 60 FPS</td> <td>1 to 60, 66, 72 FPS</td> </tr> <tr> <td>5.7K 16:9</td> <td></td> <td></td> </tr> <tr> <td>6K 2.39:1</td> <td>1 to 60 FPS</td> <td>1 to 60, 66, 72, 75 FPS</td> </tr> <tr> <td>4K 6:5</td> <td>1 to 60 FPS</td> <td>1 to 60, 66, 72 FPS</td> </tr> <tr> <td>4K 17:9</td> <td>1 to 60 FPS</td> <td>1 to 60, 66, 72, 75, 88, 90 FPS</td> </tr> <tr> <td>3.8K 16:9</td> <td></td> <td></td> </tr> <tr> <td>4K 17:9 Surround View</td> <td>1 to 48 FPS</td> <td>1 to 48 FPS</td> </tr> <tr> <td>3.8K 16:9 Surround View</td> <td></td> <td></td> </tr> <tr> <td>4K 2.39:1</td> <td>1 to 60 FPS</td> <td>1 to 60, 66, 72, 75, 88, 90 FPS</td> </tr> </tbody> </table>	Imager Mode	Shooting frame rate		ProRes 4K / QFHD			4444	422 HQ	6K 17:9	1 to 60 FPS	1 to 60, 66, 72 FPS	5.7K 16:9			6K 2.39:1	1 to 60 FPS	1 to 60, 66, 72, 75 FPS	4K 6:5	1 to 60 FPS	1 to 60, 66, 72 FPS	4K 17:9	1 to 60 FPS	1 to 60, 66, 72, 75, 88, 90 FPS	3.8K 16:9			4K 17:9 Surround View	1 to 48 FPS	1 to 48 FPS	3.8K 16:9 Surround View			4K 2.39:1	1 to 60 FPS	1 to 60, 66, 72, 75, 88, 90 FPS
Imager Mode	Shooting frame rate																																			
	ProRes 4K / QFHD																																			
	4444	422 HQ																																		
6K 17:9	1 to 60 FPS	1 to 60, 66, 72 FPS																																		
5.7K 16:9																																				
6K 2.39:1	1 to 60 FPS	1 to 60, 66, 72, 75 FPS																																		
4K 6:5	1 to 60 FPS	1 to 60, 66, 72 FPS																																		
4K 17:9	1 to 60 FPS	1 to 60, 66, 72, 75, 88, 90 FPS																																		
3.8K 16:9																																				
4K 17:9 Surround View	1 to 48 FPS	1 to 48 FPS																																		
3.8K 16:9 Surround View																																				
4K 2.39:1	1 to 60 FPS	1 to 60, 66, 72, 75, 88, 90 FPS																																		
	<p>[Note]</p> <p>Shooting frame rates of 7 or lower cannot be set in the following cases.</p> <ul style="list-style-type: none"> <li>- When Base ISO is set to ISO 3200</li> <li>- When Base ISO is set to ISO 2500 and the recording format is ProRes</li> </ul>																																			
Exposure Index	<p>Sets the EI value. The settings change as follows depending on the Project &gt; Basic Setting &gt; Base ISO (page 72) setting in the full menu.</p> <p>MPC-3628</p> <p>Base ISO 800: 200EI/250EI/320EI/400EI/500EI/640EI/<b>800EI</b>/1000EI/1250EI/1600EI/2000EI/2500EI/3200EI</p> <p>Base ISO 3200: 800EI/1000EI/1250EI/1600EI/2000EI/2500EI/<b>3200EI</b>/4000EI/5000EI/6400EI/8000EI/10000EI/12800EI</p> <p>MPC-3626</p> <p>ISO 500: 125EI/160EI/200EI/250EI/320EI/400EI/<b>500EI</b>/640EI/800EI/1000EI/1250EI/1600EI/2000EI</p> <p>ISO 2500: 640EI/800EI/1000EI/1250EI/1600EI/2000EI/<b>2500EI</b>/3200EI/4000EI/5000EI/6400EI/8000EI/10000EI</p>																																			
Gain	<p>Sets the base sensitivity.</p> <p>-6dB/-3dB/<b>0dB</b>/3dB/6dB/9dB/12dB/15dB/18dB</p> <p>[Note]</p> <p>Configurable only when an RM-B170 or other remote control unit is connected and Technical &gt; Special Configuration &gt; RM/RCP Paint Control (page 91) is set to On in the full menu.</p>																																			

Item	Description
Shutter	<p>Sets the electronic shutter angle/shutter speed.</p> <p>Select from preset values registered as shutter steps.</p> <p>[Note]</p> <p>Not available when the electronic shutter operation is set to Continuous.</p> <p>Displays the following selection options depending on the Technical &gt; System Configuration &gt; Shutter Mode (page 87) setting in the full menu.</p> <p>Angle (Δ): Shutter angle indicator 360.0/<b>180.0</b>/172.8/144.0/90.0/45.0/22.5/11.2/5.6<sup>1)</sup></p> <p>Speed (SS): Shutter speed indicator 1/24, 1/25, 1/30, 1/48, 1/50, 1/60, 1/100, 1/120, 1/250, 1/500, 1/1000, 1/2000<sup>1)</sup></p>
ND Filter	<p>Sets the density of the ND filter. The following settings are available.</p> <p><b>Clear</b>/0.3/0.6/0.9/1.2/1.5/1.8/2.1/2.4</p>
WB (White Balance)	<p>Sets the color temperature of the white balance.</p> <p>Select from preset values registered as WB steps.</p> <p><b>3200K+00</b>/4300K+00/5500K+00<sup>1)</sup></p>

1) The selection options can be changed using Step Edit on the Home screen of the sub display.

# Clip Operations on the Mini Display

You can play a clip by selecting the clip to play from the clip screen displayed on the mini display.

## Clip Screen

Press the CLIPS button (page 9) on the Operator side to display the clip screen for playable media on the mini display.

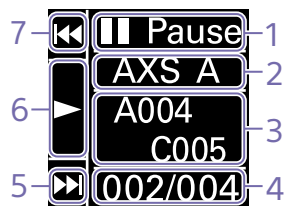

### 1. Playback status indicator

Displays the clip playback status.

### 2. Active playback media

Displays the active playback media of the selected clip.

### 3. Clip name indicator

Displays the clip name of the selected clip.

### 4. Clip position in playback media

Displays the clip number/total number of the selected clip.

### 5. F Fwd/Next button

Jumps to the next clip when the **↓** button (ITEM key 3) is pressed while playback is paused.

Fast forwards the clip when the **↓** button (ITEM key 3) is pressed during playback.

### 6. Play/Pause button

Plays/pauses clip playback when the **●** button (ITEM key 2) is pressed.

### 7. F Rev/Prev button

Jumps to the previous clip when the **↑** button (ITEM key 1) is pressed while playback is paused.

Fast reverses the clip when the **↑** button (ITEM key 1) is pressed during playback.

## Playback

You can play recorded clips while the unit is in standby mode.

**1** Insert the AXS memory card to play.

**2** Press the CLIPS button (page 9) on the Operator side.  
The active playback clip appears on the mini display.

**3** Use the Prev button (ITEM key 1) or Next button (ITEM key 3) to select a clip to play.

**3** Use the Prev button (ITEM key 1) or Next button (ITEM key 3) to select a clip to play.

**4** Press the Play/Pause button (ITEM key 2).  
The playback image appears on the viewfinder/monitor screen.



## Playback operations

Playback operation is performed using the buttons on the mini display (page 99).

Play/Pause button: Pause playback. To resume playback, press this button again.

F Fwd button/F Rev button: Fast forward/reverse. To return to normal playback, press the Play/Pause button.

## Monitoring audio

In normal playback mode, you can monitor the recorded audio through the built-in speaker (page 9) or connected headphones.

When headphones are connected to the headphones connector (page 9), the built-in speaker is turned off.

You can select the channel to monitor and adjust the volume using Audio category > Monitor CH and Monitor Level (page 57) in the menu.

## Switching between AXS memory cards

When two AXS memory cards are loaded, press the SLOT SELECT button (page 9) to switch memory cards. When the clip list screen is displayed on the sub display, you can also press ITEM key 1 on the sub display to switch.

### [Note]

You cannot switch AXS memory cards during playback. Continuous playback of cards in slots A and B is not possible.

# Network Setup and Operations

Connecting the unit to a network allows you to control various settings of the unit from a computer, smartphone, tablet, or other device and to display information about the unit.

## [Note]

When connecting to the Internet, connect via a router, a device with a router function, or a firewall to avoid external attack.

## Overview of Network Function

When the unit and a device are connected via wired LAN or wireless LAN, the unit can be accessed from a browser on the device, displaying the web remote control and enabling the following operations.

- Control recording on the unit (page 103)
- Control playback on the unit (page 103)
- Configure shooting settings on the unit (page 103)
- Control the lens attached to the unit (page 104)
- Configure and operate assignable buttons on the unit (page 104)

Using the web remote control allows you to start/stop recording or configure settings remotely, and is useful in applications where the unit is fixed in a remote location or mounted on a crane, for example.

## Compatible Devices

You can use a computer, smartphone, or tablet to configure and operate the unit. The verified devices, OS, and browsers are shown in the following table.

Device	OS	Browser
Computer	Microsoft Windows 10/11	Chrome
	macOS 11.x	Safari
Smartphone	Android 10.x/11.x	Chrome
	iOS 14.x/15	Safari
Tablet	Android 10.x/11.x	Chrome
	iPadOS 14.x	Safari

## [Note]

The controls may not be displayed normally, depending on the version of the browser you are using. Operation in the following versions of the browsers has been verified.

Safari: 14/15  
Chrome: 93

## Connecting the Unit and Device via Wired LAN

You can connect the unit to a device via a wired LAN connection or via a router using the network connector of the unit.

- 1 Connect the network connector (page 12) of the unit and computer using a LAN cable. Or connect the network connector of the unit and router using a LAN cable.
- 2 Set Technical > Network > Setting (page 87) in the full menu to LAN.

## [Note]

Grayed out and cannot be changed if a password is not configured using Technical > Authentication > Password (page 87) in the full menu.

- 3 Configure the unit.

To obtain the IP address of the unit automatically:

Set Technical > Network > LAN > DHCP (page 88) in the full menu to On, then select Set to apply the setting.

To enter the IP address of the unit manually:

Set Technical > Network > LAN > DHCP in the full menu to Off, enter the specified IP address using LAN > IP Address, and select Set to apply the setting.

## [Note]

Select Set on the Technical > Network > LAN setup screen in the full menu. If Set is not selected, the configured settings are not applied.

When the wired LAN connection is enabled, the LAN icon of the network connection status indicator (page 15) is displayed on the viewfinder/monitor screen.

## Connecting the Unit and Device via Wireless LAN

The unit can connect to devices using wireless LAN connection by attaching the CBK-WA02 Wireless LAN Adaptor (option) to the unit.

## Attaching the CBK-WA02

## [Note]

Always turn the unit off before connecting the CBK-WA02.

- 1 Attach the USB extension adaptor to the point shown in the following diagram, and turn the retaining screw clockwise to secure it in position.

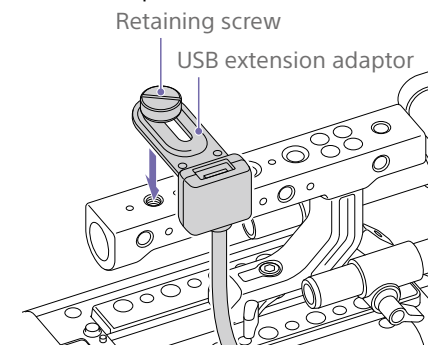

You can adjust the position of the USB extension adaptor over the range shown in the following diagram.

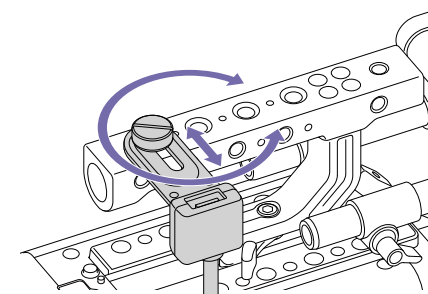

- 2 Attach the protective cap (supplied) to the USB connector of the USB extension adaptor.

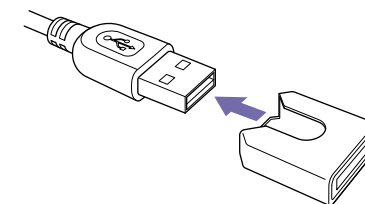

- 3** Open the cover of the external device connector block, and insert the USB connector of the USB extension adaptor into the external device connector.

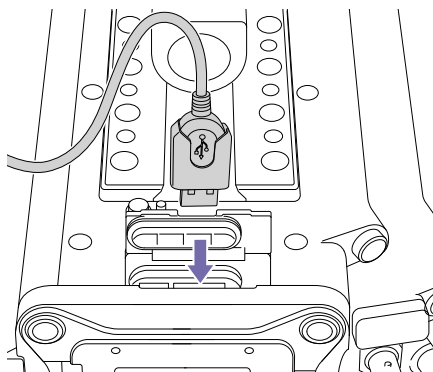

- 4** Insert the CBK-WA02 into the USB connector of the USB extension adaptor.

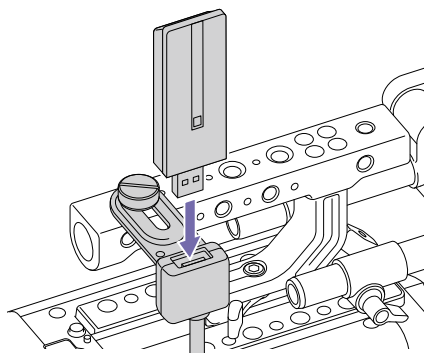

### Connecting in access point mode

The unit can connect to devices that are set up as an access point via wireless LAN.

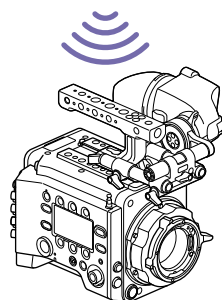
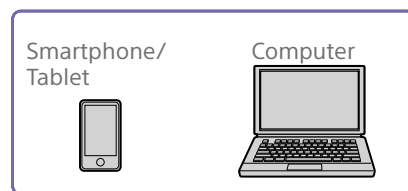

### Connecting using WPS-equipped devices

Devices that support WPS can be connected using WPS.

- 1** Set Technical > Network > Setting (page 87) in the full menu to Wireless.

**[Note]**

Grayed out and cannot be changed if a password is not configured using Technical > Authentication > Password (page 87) in the full menu.

- 2** Set Technical > Network > Wireless > Network Mode (page 88) in the full menu to Access Point.

- 3** Select Technical > Network > Wireless > WPS (page 88) in the full menu.

- 4** Select Run by turning the MENU dial, then press the MENU dial.

- 5** Open the device Network Settings or Wi-Fi Settings, and turn Wi-Fi on.

- 6** Press the WPS push button in the device Network Settings or Wi-Fi Settings preferences.

**[Note]**

The steps will vary depending on the device used.

### Connecting using SSID and password on the device

Connect by entering the SSID and password on the device.

- 1** Set Technical > Network > Setting (page 87) in the full menu to Wireless.

**[Note]**

Grayed out and cannot be changed if a password is not configured using Technical > Authentication > Password (page 87) in the full menu.

- 2** Set Technical > Network > Wireless > Network Mode (page 88) in the full menu to Access Point.

- 3** Open the device Network Settings or Wi-Fi Settings, and turn Wi-Fi on.

- 4** Select the unit's SSID from the Wi-Fi network SSID list, then enter a password to connect.  
For the unit's SSID and password, see Technical > Network > Wireless > SSID and Password (page 88) in the full menu.

**[Note]**

The steps will vary depending on the device used.

### Connecting in station mode

The unit can connect to existing wireless LAN access points as a client.

The device connects via the access point.

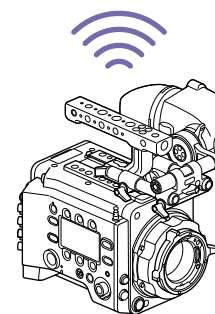
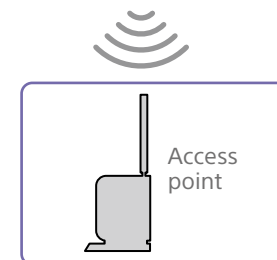
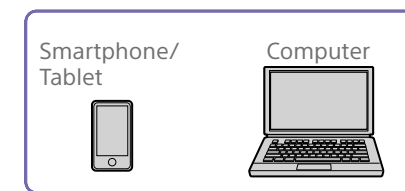

### Connecting to an access point using WPS

If an access point supports the WPS function, you can connect using a basic setting.

- 1** Turn the access point on.

- 2** Turn the unit on.

- 3** Set Technical > Network > Setting (page 87) in the full menu to Wireless.

**[Note]**

Grayed out and cannot be changed if a password is not configured using Technical > Authentication > Password (page 87) in the full menu.

4 Set Technical > Network > Wireless > Network Mode (page 88) in the full menu to Station.

5 Select Technical > Network > Wireless > WPS (page 88) in the full menu.

6 Select Run by turning the MENU dial, then press the MENU dial.

7 Press the access point WPS button. For details about WPS button operation, refer to the instruction manual for the access point.

**[Note]**  
If the connection fails, perform the procedure again from step 1.

**Connecting by entering a SSID and password**  
Connect by entering the SSID and password on the unit.

1 Set Technical > Network > Setting (page 87) in the full menu to Wireless.

**[Note]**  
Grayed out and cannot be changed if a password is not configured using Technical > Authentication > Password (page 87) in the full menu.

2 Set Technical > Network > Wireless > Network Mode (page 88) in the full menu to Station.

3 Set the following items in Technical > Network > Wireless (page 88) in the full menu.

- SSID
- Password
- DHCP
- IP Address
- Subnet Mask

4 Select Set to confirm.

**[Note]**  
Always use Set to confirm the settings. If the settings are not confirmed using Set, the configured settings are not applied.

**Connecting using access point auto detection**  
The unit can connect by detecting connection access points automatically, without having to enter the SSID manually.

1 Set Technical > Network > Setting (page 87) in the full menu to Wireless.

**[Note]**  
Grayed out and cannot be changed if a password is not configured using Technical > Authentication > Password (page 87) in the full menu.

2 Set Technical > Network > Wireless > Network Mode (page 88) in the full menu to Station.

3 Select Technical > Network > Wireless > Scan Networks (page 88) in the full menu.

4 Select Run by turning the MENU dial, then press the MENU dial. The unit starts auto detection of connection access points. When auto detection finishes, networks available for connection are displayed in a list.

5 Select the network to be connected by turning the MENU dial, then press the MENU dial.

6 Select Set to confirm. A password input screen appears.

7 Enter the password, then select Done. The Wireless preferences screen appears.

8 Set the following items in Technical > Network > Wireless in the full menu, then select Set to confirm.

- DHCP
- IP Address
- Subnet Mask

**[Note]**  
Always use Set to confirm the settings. If the settings are not confirmed using Set, the configured settings are not applied.

## Displaying the Web Remote Control

The web remote control is displayed when the unit is accessed from the browser of a device. The web remote control screen is automatically resized to match the screen size of the connected device.

1 Connect the unit and device as described in “Connecting the Unit and Device via Wired LAN” or “Connecting the Unit and Device via Wireless LAN”.

2 Launch a browser on the device and enter “http://IP address of unit/rm.html” in the URL bar. You can check the IP address of the unit using Info category > System > IP Address (page 58) in the menu. For example, if the IP address is 192.168.1.1, enter “http://192.168.1.1/rm.html” in the URL bar.

3 Enter the user name and password (Technical > Authentication (page 87) in the full menu) on the browser screen. When connection is successful, the web remote control screen appears on the device.

**[Note]**  
The page may not be displayed correctly on a smartphone or other device if the viewing mode is set to mobile pages. Change the viewing mode to desktop pages.

## Web Remote Control Screen

### Global Menu

Select  (Global Menu) at the top left of the web remote control screen to display the Global Menu. Select the item you want to configure.

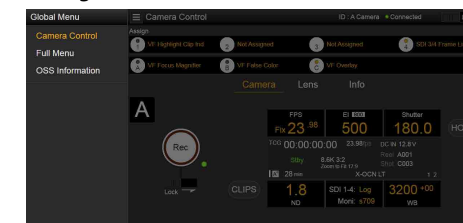

### Camera Control screen

The Camera Control screen contains the Camera screen, Lens screen, and Info screen. Select the Camera tab to display the Camera screen, the Lens tab to display the Lens screen, and the Info tab to display the Info screen.

Various display items and operation buttons are displayed on the Camera Control screen (common to Camera screen, Lens screen, Info screen, and playback screen).

- Network connection status (Connected/Disconnected)
  - Camera ID\*
  - Rec button
  - Assignable buttons (1 to 4, A to C)
- \* The Camera ID text color is the same color set using Frame Line A/B Setup > Color.

## Camera screen

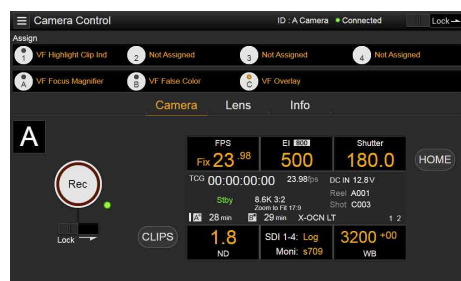

You can configure the same items that are displayed on the Home screen of the sub display on the Camera screen.

### [Note]

Similarly as for the sub display screen, the EI display area switches to become the Gain display area and restrictions apply to the items (page 38) that can be operated when Technical > Special Configuration > RMP/ RCP Paint Control (page 91) is set to On in the full menu.

- Shooting settings (page 36)  
FPS, EI, Shutter, ND, LUT, WB
- Camera status display (page 37)  
Operating status, time data, audio level meter, clip name, recording format, media status/free space, battery voltage/remaining battery capacity

## Lens screen



Lens controls for zoom, focus, and iris are displayed on the Lens screen.

## Info screen

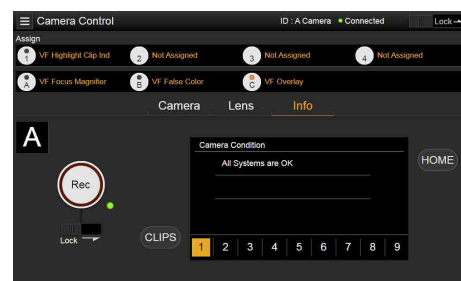

The Info screen displays the same contents as the Info category (page 58) of the sub display menu screen, allowing you to check the status of the camera, media, and battery.

## Full Menu screen

Select Full Menu in the Global Menu to display the full menu screen in order to configure items (page 64).

### [Note]

Some items may not be configurable from the web remote control.

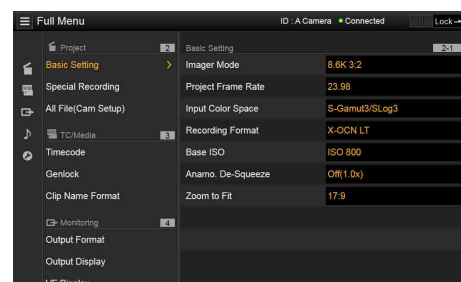

## OSS (Open Source Software) Information screen

Select OSS Information in the Global Menu to display the open source software information.

## Playback screen

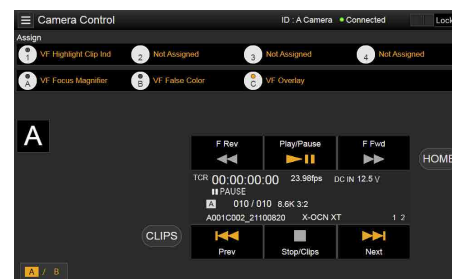

You can play clips on the playback screen. Information about the playback clip is also displayed in the status display area on the screen.

- Function display (page 94)  
F Rev, Play/Pause, F Fwd, Prev, Stop/Clips, Next
- Playback status display (page 94)  
Time data, clip number, frame rate/playback clip picture size, special recording mode, audio level meter, playback clip format (codec), icon (protection), clip name, playback media, and playback status.

## HOME button

Press the HOME button to return to the Camera screen.

When the camera is in playback mode, pressing the HOME button returns to the camera shooting status even when the playback screen is displayed on the web remote control screen.

## CLIPS button

Press the CLIPS button to return to the playback screen. (The unit switches to the clip list screen (page 93).)

## Recording

Press the Rec button on the Camera Control screen to start recording and to display the REC lamp in red. Click again to stop recording. The Rec button is enabled when the REC ACTIVE lamp below and to the right of the Rec button is green.

## To lock the Rec button

Slide the Lock slider below the Rec button to the right to disable the Rec button operation.

## Playback

Press the CLIPS button on the Camera screen to return to the playback screen in playback state. (The sub display on the unit displays the clip list screen (page 93).) Select the clip you want to play on the playback screen, and use the playback controls to play the clip.

## To switch between playback media

Press the media select button to switch the media slot for playback.

## Configuring Shooting Settings

You can configure and operate the same items that are displayed on the Home screen of the sub display of the unit on the Camera screen.

### [Note]

Step Edit operation for Shutter is not supported.

The operation is the same as on the Home screen of the sub display.

*“Operations on the Home Screen of the Sub Display” (page 38)*

## Controlling the Lens

You can check the status of E-mount lens settings (zoom, focus, iris) on the Lens screen, and also control the zoom, focus, and iris using sliders if the attached lens is controllable. PL-mount Cooke lens communication control is supported on the Lens screen. Also, 12-pin lens communication control is supported on the Lens screen.

**[Note]**  
The sliders are grayed out and cannot be operated when an RM-B170 or other remote control unit is connected and Technical > Special Configuration > RM/RCP Paint Control (page 91) is set to On in the full menu. The focus and zoom sliders are grayed out when remote control of focus and zoom, respectively, are enabled.

## Configuring/Operating Assignable Buttons

Assignable buttons 1 to 4 and viewfinder assignable buttons A to C are displayed on the Camera Control screen. Press assignable buttons 1 to 4 and DVF-EL200 assignable buttons A to C to toggle the assigned functions between on/off (enabled/disabled) or to activate the assigned functions in the same way as assignable buttons on the unit. Select the function name of an assignable button to display selection options in a pull-

down. Select an option to change the function assigned to the assignable button.

*“Functions that can be Assigned to Assignable Buttons 1 to 4” (page 50)*

*“Functions that can be Assigned to Viewfinder (DVF-EL200) Assignable Buttons A to C” (page 52)*

**[Note]**  
Functions assigned to assignable switches that are enabled only while a button is pressed or are enabled by a long press cannot be operated from the assignable buttons of the web remote control. These comprise the following functions.

- Press&Hold for SDI12 Log
- Press&Hold for SDI34 Log
- Press & Hold for VF Log
- Iris Open (1/16 stop)
- Iris Close (1/16 stop)
- Monitor Focus Magnifier (when Monitor Magnifier Mode is set to Press & Hold)
- VF Focus Magnifier (when VF Magnifier Mode is set to Press & Hold)

## Loading Various Files

You can load a User 3D LUT file, ART file, or ASC CDL file into the unit using the LUT selection screen of the Camera screen.

### Displaying the LUT selection screen

Click/tap the LUT selection area on the Home screen of the sub display of the Camera screen.

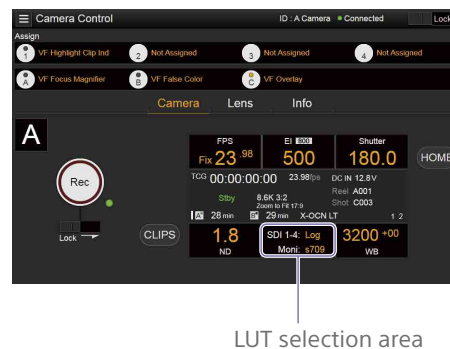

The LUT selection screen appears.

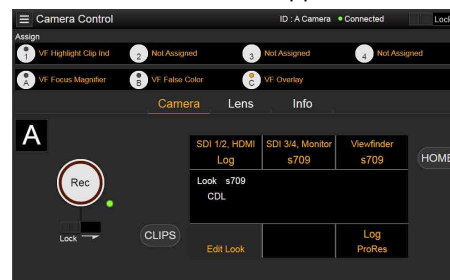

### Loading a User 3D LUT file

You can load a User 3D LUT file into the unit from a network-connected device.

1 Click/tap the Edit Look button on the LUT selection screen. The Look selection screen appears.

2 Click/tap the Load File button. A file type selection screen appears.

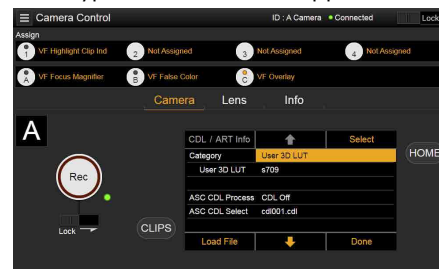

3 Move the cursor to Load User 3D LUT File and click/tap the Select button. A load destination selection screen appears.

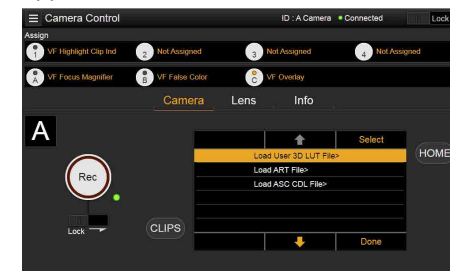

4 Move the cursor to Web and click/tap the Select button.

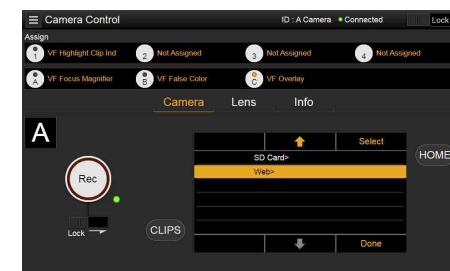

The load destination numbers (01 to 16) are displayed. A file name is displayed for loaded numbers.

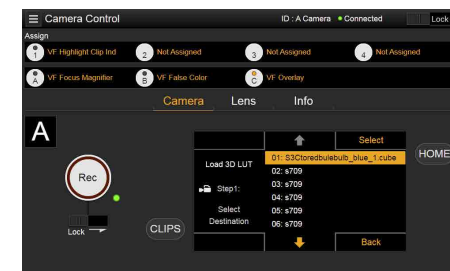



- 5 Use the **↑** button, **↓** button, or direct touch to move the cursor to a load destination number and then click/tap the Select button.

- 6 Open a folder on the network-connected device and select the file to load. When the file is loaded successfully, "Successfully loaded" is displayed.

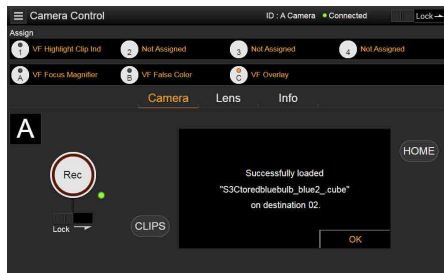

### Loading an ART file

You can load an ART file into the unit from a network-connected device.

- 1 Click/tap the Edit Look button on the LUT selection screen. The Look selection screen appears.
- 2 Click/tap the Load File button. A file type selection screen appears.

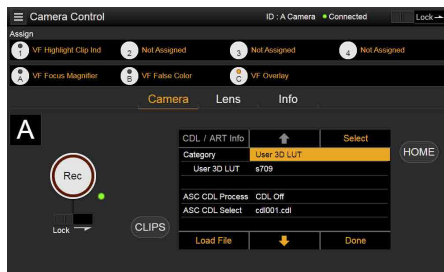

- 3 Move the cursor to Load ART File and click/tap the Select button. A load destination selection screen appears.

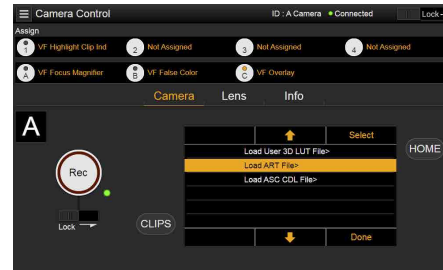

- 4 Move the cursor to Web and click/tap the Select button.

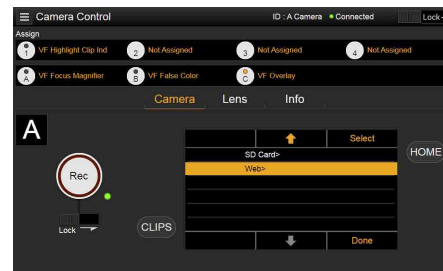

The load destination numbers (01 to 16) are displayed. A file name is displayed for loaded numbers.

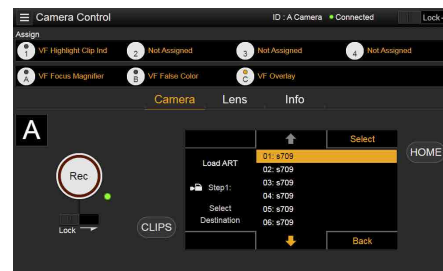

- 5 Use the **↑** button, **↓** button, or direct touch to move the cursor to a load destination number and then click/tap the Select button.

- 6 Open a folder on the network-connected device and select the file to load. When the file is loaded successfully, "Successfully loaded" is displayed.

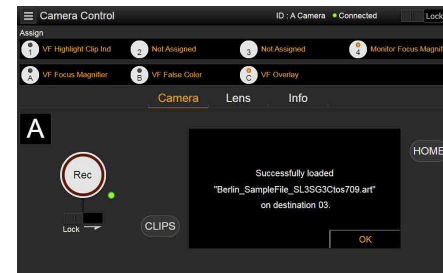

### Loading an ASC CDL file

You can load an ASC CDL file into the unit from a network-connected device.

- 1 Click/tap the Edit Look button on the LUT selection screen. The Look selection screen appears.
- 2 Click/tap the Load File button. A file type selection screen appears.

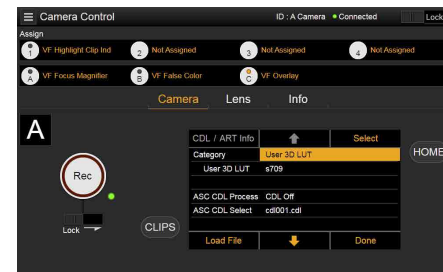

- 3 Move the cursor to Load ASC CDL File and click/tap the Select button. A load destination selection screen appears.

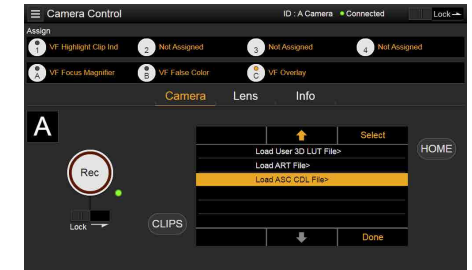

- 4 Move the cursor to Web and click/tap the Select button.

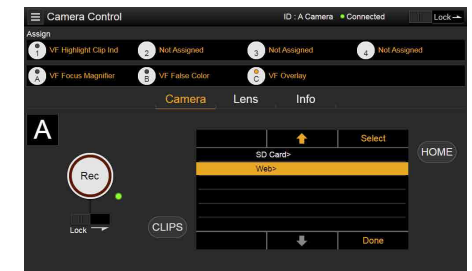

- 5 Open a folder on the network-connected device and select the file to load. When the file is loaded successfully, "Successfully loaded" is displayed.

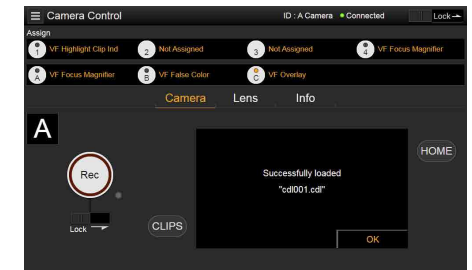

## Changing Saturation in an ASC CDL file

You can change the Saturation setting in an ASC CDL file using the LUT selection screen of the Camera screen.

- 1 Click/tap the Edit Look button on the LUT selection screen.  
The Look selection screen appears.
- 2 Move the cursor to ASC CDL Select, and click/tap CDL/ART Info.  
The ASC CDL file information screen appears.

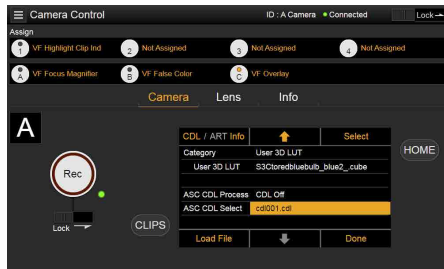

- 3 Click/tap the Edit button.  
The Saturation edit screen appears.

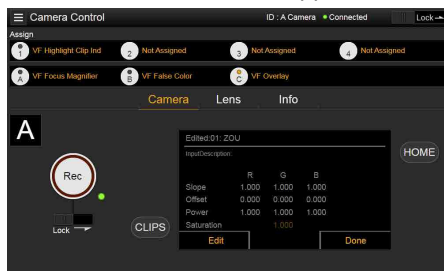

- 4 Click/tap the + button or – button to change the setting.

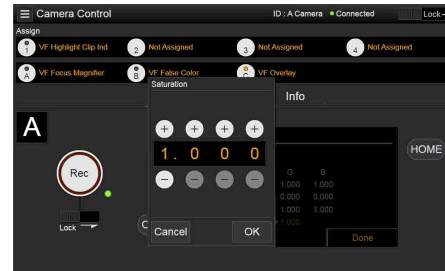

- 5 Click/tap the OK button to apply the setting.

## Locking the Web Remote Control Screen

You can disable web remote control screen operation by sliding the Lock slider to the right on the top right of the web remote control screen.

# Basic Operation

Basic recording can be performed with the following procedures.

- 1 Make sure that the necessary devices are attached to the unit and power is supplied to them.
- 2 Set the power switch (page 9) to the ON position.  
The recording screen is displayed on the viewfinder screen.
- 3 Load the memory card(s).  
If you load two AXS memory cards, recording is continued by automatically switching to the second card when the first card becomes full.
- 4 Press the REC button (pages 9, 11).  
The REC lamp lights and recording begins.  
**[Note]**  
If the unit cannot start recording immediately after the pressing the REC button, the REC lamp flashes. The REC lamp lights when recording starts.
- 5 To stop recording, press the REC button again.  
Recording stops and the unit enters STBY (recording standby) mode.  
When you stop recording, the video, audio, and subsidiary data from the start to the end of the recording are recorded as a single clip.

## Clip names

Clip names are recorded using the "Cam ID + Reel#" format. The clip name is created according to the following rules.

- When there is already a clip that is stored using the "Cam ID + Reel#" name format on the inserted AXS memory card, the new file inherits from the last file.  
Example: If "B002C003\_XXXXXXXX" exists on the AXS memory card, the next created clip will be named "B002C004\_XXXXXXXX."
- If the inserted AXS memory card has no files, "1" is added to the Reel Number of the clip that was recorded last.  
Example: If you record on empty card 2 after recording up to "D001CXXX\_XXXXXXXX" on card 1, the next created clip will be named "D002C001\_XXXXXXXX." The clip name is displayed underlined until recording starts.
- If you set Camera ID and Reel Number using the TC/Media category in the menu, that information is applied.  
Example: If you change Camera ID to "F" and Reel Number to "001" in the menu for the AXS memory card that has recorded up to "E003CXXX\_XXXXXXXX," the next clip will be named "F001CXXX\_XXXXXXXX." When you change Camera ID only, Reel Number is changed to "001."

# Useful Functions

## User Frame Line Display

You can select whether to display arbitrarily configured user frame lines or a fixed aspect ratio.

User Frame Line 1 and User Frame Line 2 can be set for user frame lines.

To set user-configured lines, select Variable using Monitoring > User Frame Line 1 (page 81) or User Frame Line 2 (page 82) > Select in the full menu, and specify the Width, Height, H Position, and V Position menu items.

To set a fixed aspect ratio, select Preset using Monitoring > User Frame Line 1 (page 81) or User Frame Line 2 (page 82) > Select in the full menu, and specify the Preset Aspect Ratio, Scaling, and Preset Aspect Ratio Type menu items.

You can check the aspect ratio, number of pixels, and anamorphic ratio of configured user frame lines for both user-configured lines or a fixed aspect ratio using Aspect Ratio(Pixels) (page 82).

### [Notes]

- The User Frame Line 2 > Preset Aspect Ratio Type setting is set to Line (fixed).
- The anamorphic ratio is not displayed for effective picture size (Imager Mode) settings for which the anamorphic ratio cannot be configured.

## Assignable button operations

You can show/hide User Frame Line 1 and User Frame Line 2 configured for Line A by assigning Line A: User Frame Disp. to any of assignable buttons 1 to 4, viewfinder assignable buttons A to C, and ITEM keys 1 to 5 (page 48).

Each time the assignable button is pressed, the display switches between User Frame Line 1 and 2 display → User Frame Line 1 display → User Frame Line 2 display → User Frame Line 1 and 2 hidden.

Similarly, you can show/hide User Frame Line 1 and User Frame Line 2 configured for Line B by assigning Line B: User Frame Disp. to an assignable button or key.

You can also show/hide Aspect Ratio configured for Line A or Line B by assigning Line A: Aspect Ratio Disp. or Line B: Aspect Ratio Disp. to any of assignable buttons 1 to 4, viewfinder assignable buttons A to C, and ITEM keys 1 to 5. Each time the assignable button is pressed, the display switches between Aspect Ratio display and Aspect Ratio hidden.

## Picture Cache Recording

The unit always maintains a cache of video and audio data in memory when shooting, allowing you to record several seconds of footage before the start of recording.

When you start recording with Project > Special Recording > Cache Rec Select (page 73) set to On in the full menu, video of duration set by Project > Special Recording > Max Cache Rec Duration (page 73) is recorded retroactively.

You can also turn picture cache recording on/off using an assignable button assigned with the Picture Cache Rec function.

### [Notes]

- Restrictions to the Max Cache Rec Duration setting may apply, depending on the project frame rate, recording format, and recording media. For details, see page 73.
- Changing system settings, such as the recording format, clears all images stored in memory. Consequently, images shot just before changing settings cannot be recorded, if recording is started immediately after changing settings. Picture cache mode is automatically released.
- The picture cache settings cannot be changed during recording.

## Recording Review (Rec Review)

You can review the last recorded clip on the screen by assigning the Rec Review function to one of assignable buttons 1 to 4 (page 48).

When you stop recording and press the button assigned with Rec Review, the clip is played at normal speed starting from the first frame. The clip is played to the end, then Rec Review ends and the unit returns to STBY (recording standby) mode.

If the HOME button is pressed on the Operator side or Assistant side during playback, playback stops and the unit switches to shooting mode.

## Zoom to Fit

When shooting and recording a scene that is wider than the actual desired picture size, you can enlarge the recorded image to the desired picture size on the viewfinder screen or monitor screen.

Configure using the Project > Basic Setting > Zoom to Fit (page 73) setting in the full menu.

### [Note]

During playback, the Zoom to Fit function is disabled.

## High-Definition Focus Magnifier Function

You can magnify the display for the viewfinder screen or Monitor output.

By pressing the FOCUS MAG button of the viewfinder (DVF-EL200, DVF-L700) attached to the unit, or pressing an assignable button assigned with the VF Focus Magnifier function, you can expand the center part of the viewfinder screen, making it is easier to adjust the focus. By pressing an assignable button assigned with the Monitor Focus Magnifier function, you can expand the center part of the Monitor output image, making it is easier to adjust the focus.

The magnified display does not affect the recorded image or other output signals, other than the Monitor output.

Normal focus magnification reduces the resolution because it simply magnifies a part of the displayed image. However, the two-times (×2) focusing by the unit provides focus magnification while maintaining the display resolution by cutting out the portion to magnify from the 4K image instead of the recorded image or other output signals, other than the Monitor output.

Four-times (×4) focus magnification selection is also supported using the 4K image cutout function.

The following focus magnification functions can be assigned to an assignable button (page 48).

Viewfinder focus magnifier function: VF Focus Magnifier

Monitor output focus magnifier function: Monitor Focus Magnifier

The magnification sequence of the FOCUS MAG button and assignable buttons assigned with a focus magnification function is set using the following items.

Viewfinder screen: Monitoring > VF Display > VF Magnifier Ratio (page 78) in the full menu

Monitor output: Monitoring > Output Display > Monitor Magnifier Ratio (page 77) in the full menu

When VF Magnifier Ratio is set to ×2.0/×4.0, the magnification sequence each time you press an assignable button assigned with VF Focus Magnifier is ×2.0 → ×4.0 → ×1.0 → ×2.0.

Similarly, when Monitor Magnifier Ratio is set to ×2.0/×4.0, the magnification changes each time you press an assignable button assigned with Monitor Focus Magnifier.

### [Notes]

- In High Frame Rate mode (shooting frame rate of 61 fps or higher), the ×2/×4 focus display image resolution decreases because cutout display from a 4K image is not supported.
- When Project Frame Rate is set to 59.94 or 50 and the Monitor output setting is 1920×1080P, Monitor Magnifier Ratio cannot be set to ×4.0 or ×2.0/×4.0. When the Monitor output setting is 1920×1080i, Monitor Focus Magnifier does not function.
- Monitor Focus Magnifier is also applied to the HDMI output if the HDMI output has the same output format as the Monitor output. You can check the setting using Monitoring > Overlays/Frame Line > HDMI (page 79) in the full menu. The HDMI output is the same as the Monitor output if HDMI is set to "Same as Monitor".

## Operation of assignable buttons assigned with focus magnifier functions

You can set whether an assignable button assigned with a focus magnifier function will toggle the function on/off each time the button is pressed or turn the function on only while the button is pressed.

Viewfinder screen: Monitoring > VF Display > VF Magnifier Mode (page 78) in the full menu

Monitor output: Monitoring > Output Display > Monitor Magnifier Mode (page 77) in the full menu

## Highlight Clip Indicator

You can display clipped highlight areas in red in the Monitor output image and viewfinder output image.

Press the assignable buttons (pages 48, 50) assigned with Monitor Highlight Clip Ind and VF Highlight Clip Ind to switch the highlight clip indicators on/off.

### [Note]

Highlight clip indicators do not function when Technical > Special Configuration > RM/RCP Paint Control (page 91) is set to On in the full menu.

## High Key / Low Key

You can check for blown-out highlights and blocked-out shadows in the Monitor output image and viewfinder output image.

Enable High Key to differentiate areas of high luminance, making them easier to see, to check for blown-out highlights.

Enable Low Key to differentiate areas of low luminance, making them easier to see, to check for blocked-out shadows.

Press assignable buttons 1 to 4 (page 50) assigned with Monitor High/Low Key and VF High/Low Key to switch the high key and low key settings.

### [Note]

High/Low key does not function when Technical > Special Configuration > RM/RCP Paint Control (page 91) is set to On in the full menu.

## False Color Display

You can display false color in the viewfinder by pressing the B/False Color button (DVF-EL200) or SPARE button (DVF-L700) on the viewfinder attached to the unit.

You can also display false color on the monitor output.

Display color	Signal level	
	S-Log3 (default)	S-Log2 (PMW-F55 reference value)
Red	93.4% to 96.1%	105.5% to 109.5%
Yellow	91.3% to 93.4%	102.5% to 105.5%
Orange	87.7% to 90.6%	97.4% to 101.5%
Pink	54.3% to 58.0%	50.2% to 55.2%
Light pink	47.8% to 50.8% (18% gray + 1 stop)	41.5% to 45.4% (18% gray + 1 stop)
Cyan	43.8% to 46.5%	36.3% to 39.6%
Green	38.9% to 42.2% (18% gray)	30.4% to 34.4% (18% gray)
Light blue	24.6% to 34.4%	15.5% to 25.2%
Blue	3.5% to 5.6%	3.0% to 4.0%
Purple	-7.3% to 3.5%	-7.3% to 3.0%

- You can set whether to use the preset on/off setting and threshold of each false color in the viewfinder and monitor output, or to set colors manually using Technical > False Color (page 90).
- You can turn the false color function display in a viewfinder on/off by pressing an assignable button assigned with VF False Color.
- You can turn the false color function display on a monitor on/off by pressing an assignable button assigned with Monitor False Color.

### [Note]

The false color function does not operate when Technical > Special Configuration > RM/RCP Paint Control (page 91) is set to On in the full menu.

## Viewfinder Double Speed Scan Function

If the project frame rate is 23.98P, 24P, 25P, or 29.97P, the image may become blurred and hard to see due to low frame frequency when you shoot while swaying the unit to the right and the left.

In this case, you can decrease image blur and make it easier to see by activating the viewfinder double speed scan function.

To activate the function, set **Monitoring > VF Function > Double Speed Scan** (page 78) in the full menu to On.

### [Notes]

- When this function is activated, the shutter angle of the electronic shutter function is limited to 180 degrees or lower.
- This function is set to Off during variable speed shooting.
- This function is enabled for the following combinations of image size and project frame rate.
  - MPC-3628:
    - 5.8K 6:5 (23.98p, 24p)
    - 5.8K 17:9 (23.98p, 24p, 25p, 29.97p)
    - 5.4K 16:9 (23.98p, 24p, 25p, 29.97p)
  - MPC-3626:
    - 4K 4:3 (23.98p, 24p)
    - 4K 17:9 (23.98p, 24p, 25p, 29.97p)
    - 4K 17:9 Surround View (23.98p, 24p)
    - 4K 2.39:1 (23.98p, 24p, 25p, 29.97p)
    - 3.8K 16:9 (23.98p, 24p, 25p, 29.97p)
    - 3.8K 16:9 Surround View (23.98p, 24p)

## User 3D LUT

You can load a CUBE file (\*.cube) for a 17-point, 33-point, or 65-point 3D LUT created using RAW Viewer or DaVinci Resolve (by Blackmagic Design Pty. Ltd.) (page 41).

You can also load a User 3D LUT file into the unit via a network (page 104).

Set Input Color Space to match the input color space of when the CUBE file was created.

If the file was created using S-Gamut3.Cine/SLog3, set Project category > Basic Setting > Input Color Space (page 72) in the menu to S-Gamut3.Cine/SLog3.

Save the User 3D LUT file in the following directory on the SD card.

PRIVATE\SONY\PRO\LUT\

### [Note]

A 65-point cube data is reduced to a 33-point cube and then loaded.

## ART

You can import ART (Advanced Rendering Transform) files (\*.art) created using RAW Viewer into the camcorder (page 41).

You can also load an ART file into the unit via a network (page 105).

An ART file is a Sony proprietary Look file created in a binary format. Using an ART file supports higher quality monitor output than importing a user 3D LUT into the unit.

Save the created ART file for the unit in the following directory on the SD card.

MPC-3628:

PRIVATE\SONY\PRO\CAMERA\MPC3628

MPC-3626:

PRIVATE\SONY\PRO\CAMERA\MPC3626

### [Note]

MPC-3610 ART files are not compatible.

## ASC CDL

You can import ASC CDL (The American Society of Cinematographers Color Decision List) files (\*.cdl) created by external tools into the unit (page 42).

You can also load an ASC CDL file into the unit via a network (page 105).

This allows you shoot with ASC CDL parameters applied to the Look.

Save the ASC CDL file in the following directory on the SD card.

PRIVATE\SONY\PRO\CDL\

You can also change ASC CDL parameters via a web browser and control them using Livegrade from Pomfort.

# User Configuration Data

You can save/load full menu settings in internal memory and on SD cards. This allows you to quickly recall an appropriate set of menu settings for the current situation. To save configuration data on an SD card, insert a writable SD card (page 34) into the SD card slot (page 13) before proceeding. For details about the settings saved in each file, see “Items Saved in Files” (page 139).

---

## All Files

---

All-settings files are used to save/load the configuration data of all menus. You can save up to 64 files on an SD card.

**[Note]**

Device specific data (shading, output levels, and other data that requires adjustment for the specific device) is not saved.

---

## Scene Files

---

Scene files are used to save/load adjustments to paint items for the purpose of shooting a particular scene. You can save up to five files in internal memory and up to 64 files on an SD card.

Settings can be saved or loaded when Technical > Special Configuration > RM/RCP Paint Control (page 91) is set to On in the full menu.

Scene files allow you to save the following types of data.

- Values set in the Paint menu
- Shutter, ND filter, Gain, Base ISO, Input Color Space, and NR settings
- White balance data

---

## User Gamma Files

---

You can save up to five user-defined user gamma files in internal memory.

Can be saved when Technical > Special Configuration > RM/RCP Paint Control (page 91) is set to On in the full menu.

# All Files

## Saving Configuration Data as an All File

- 1 Select Project > All File(Cam Setup) > Save SD Card (page 74) in the full menu.  
A screen for selecting an All file save destination appears.
- 2 Select a save destination by turning the MENU dial, then press the MENU dial.  
You can save files in rows with a File ID of "No File."  
Selecting a row with a specified File ID name will overwrite the selected file.  
The File ID is generated automatically, but you can modify it.
- 3 Select Run on the confirmation screen by turning the MENU dial, then press the MENU dial.

### If an error message appears

One of the following error messages may appear during or after operation. In this case, the file is not saved.

Error message	Problem	Solution
File Access NG	No recordable SD card is inserted.	Insert a recordable SD card.

## Changing the File ID

- 1 Select Project > All File(Cam Setup) > File ID (page 74) in the full menu.  
A screen for editing the File ID appears.
- 2 Select characters and enter the File ID.
- 3 Select Done by turning the MENU dial, then press the MENU dial.  
The File ID is updated.

## Loading Configuration Data

- 1 Select Project > All File(Cam Setup) > Load SD Card (page 74) in the full menu.  
An All file list screen appears.
- 2 Select the file to load by turning the MENU dial, then press the MENU dial.  
A confirmation screen appears.
- 3 Select Run by turning the MENU dial, then press the MENU dial.

### [Notes]

- When you load a file from an SD card, the data saved in internal memory is overwritten.
- Do not load a file on a device that is an older version than the device from which the file was saved. Doing so could cause a malfunction.
- The unit will reboot automatically after loading configuration data.
- The MPC-3628 cannot load an MPC-3626 All file. Also, the MPC-3626 cannot load an MPC-3628 All file.

## If a file cannot be loaded

One of the following error messages may appear during or after operation. In this case, the file is not loaded.

Error message	Problem	Solution
File Access NG	<ul style="list-style-type: none"> <li>• File loading terminated abnormally</li> <li>• Data in the corresponding file on the SD card is corrupted</li> </ul>	<ul style="list-style-type: none"> <li>• Try loading again</li> <li>• Insert the SD card again</li> <li>• Save a valid file to the SD card</li> </ul>

### [Note]

A file saved by a unit with a software option installed cannot be loaded into a unit without the corresponding software option installed.

## Restoring All Current Settings to Default Values

- 1 Select Maintenance > Reset to Default (page 92) in the full menu.  
A confirmation screen appears.
- 2 Select Run by turning the MENU dial, then press the MENU dial.

### [Note]

The unit will reboot automatically after executing.



# Scene Files

## Saving a Scene File in Internal Memory

- 1 Select Project > Scene File > Store Internal Memory (page 74) in the full menu. A scene file list screen appears. If the File ID is set to "Standard" destination, preconfigured standard settings are saved.
- 2 Select a save destination by turning the MENU dial, then press the MENU dial. The scene file is saved, overwriting any existing file, in the selected destination.
- 3 Select Run on the confirmation screen by turning the MENU dial, then press the MENU dial.

## Saving a Scene File on an SD Card

- 1 Select Project > Scene File > Save SD Card (page 74) in the full menu. A screen for selecting a scene file save destination appears.
- 2 Select a save destination by turning the MENU dial, then press the MENU dial. You can save files in rows with a File ID of "No File." Selecting a row with a specified File ID name will overwrite the selected file. The File ID is generated automatically, but you can modify it.
- 3 Select Run on the confirmation screen by turning the MENU dial, then press the MENU dial.

## Changing the File ID

- 1 Select Project > Scene File > File ID (page 74) in the full menu. A screen for editing the File ID appears.
- 2 Select characters and enter the File ID.
- 3 Select Done by turning the MENU dial, then press the MENU dial. The File ID is updated.

## Loading a Scene File from Internal Memory

- 1 Select Project > Scene File > Recall Internal Memory (page 74) in the full menu. A scene file list screen appears.
- 2 Select the file to load by turning the MENU dial, then press the MENU dial. A confirmation screen appears.
- 3 Select Run by turning the MENU dial, then press the MENU dial.

### [Note]

The MPC-3628 cannot load an MPC-3626 scene file. Also, the MPC-3626 cannot load an MPC-3628 scene file.

## Loading a Scene File from an SD Card

- 1 Select Project > Scene File > Load SD Card (page 74) in the full menu. A scene file list screen appears.
- 2 Select the file to load by turning the MENU dial, then press the MENU dial. A confirmation screen appears.
- 3 Select Run by turning the MENU dial, then press the MENU dial.

### [Note]

The MPC-3628 cannot load an MPC-3626 scene file. Also, the MPC-3626 cannot load an MPC-3628 scene file.

# User Gamma Files

## Using User Gamma Files Created with RAW Viewer V4.0 or Later

You can use user gamma files created with RAW Viewer V4.0 or later.

Save the created files in the following directory on an SD card.

MPC-3628:

PRIVATE\SONY\PRO\CAMERA\MPC3628

MPC-3626:

PRIVATE\SONY\PRO\CAMERA\MPC3626

For details about RAW Viewer V4.0 or later, contact your Sony dealer or a Sony service representative.

To perform load, check, reset, or other operations on user gamma files, set Technical > Special Configuration > RM/RCP Paint Control (page 91) to On in the full menu to enable the paint functions.

## Loading a User Gamma File from an SD Card

- 1 Select Project > User Gamma > Load SD Card (page 75) in the full menu. A user gamma file list screen appears. You can select up to five files on the user gamma file list screen.

User Gamma : Load SD Card			
No.	Name	Date/Time	Comment
01	0234567890ABC	2019/12/10 10:33	0234567890
02	0234567890	2019/12/10 10:59	0234567890
03	0234567890ABCDE	2019/12/10 11:10	0234567890
04	0234567890ABCDE	2019/12/10 11:32	0234567890
05	0234567890	2019/12/10 12:33	0234567890

### [Note]

The five load operations are performed together. Files cannot be selected and loaded individually.

- 2 Press the MENU dial. A confirmation screen appears.
- 3 Select Run by turning the MENU dial, then press the MENU dial. The five files are loaded into internal memory.

## Checking User Gamma Files Currently Stored in Internal Memory

Select Project > User Gamma > Current Settings (page 74) in the full menu to display a list of the user gamma files currently stored in internal memory.

User Gamma : Load SD Card			
No.	Name	Date/Time	Comment
01	0234567890ABC	2019/12/10 10:33	0234567890
02	0234567890	2019/12/10 10:59	0234567890
03	0234567890ABCDE	2019/12/10 11:10	0234567890
04	0234567890ABCDE	2019/12/10 11:32	0234567890
05	0234567890	2019/12/10 12:33	0234567890

### [Note]

Before loading user gamma files from an SD card, "709(800%)" is displayed under "Name" when Project > Basic Setting > Input Color Space (page 72) is set to Rec.709/User Gamma in the full menu. "HLG(Natural)" is displayed for settings other than Rec.709/User Gamma.

## Setting User Gamma Files Stored in Internal Memory

- 1 Set Project > Basic Setting > Input Color Space (page 72) to Rec.2020/User Gamma or Rec.709/User Gamma in the full menu.

### [Note]

Rec.2020/User Gamma and Rec.709/User Gamma can be selected only when Technical > Special Configuration > RM/RCP Paint Control (page 91) is set to On in the full menu.

- 2 Select one of User 1 to User 5 in Paint > Gamma > Gamma Select (page 85) in the full menu.

### [Note]

The User 1 to User 5 options in Gamma Select correspond to numbers 1 to 5 on the user gamma file list screen.

## Resetting User Gamma Files Stored in Internal Memory to Default State

- 1 Select Project > User Gamma > Reset (page 75) in the full menu. A gamma file number reset selection screen appears.
- 2 Turn the MENU dial to select the number of the gamma file to reset (1 to 5). To reset all gamma files, select All. A confirmation screen appears.
- 3 Select Run by turning the MENU dial, then press the MENU dial.

# Connecting a Remote Control Unit

When an RM-B170 Remote Control Unit, RCP-1001/1501/3100/3501 Remote Control Panel, or other control unit is connected, some functions can be controlled from that unit.

---

## Connecting a Remote Control Unit

---

Connect the camera connector of the control unit to the REMOTE connector (8-pin) of the unit using a remote control cable.

When you turn on the unit after making the connection, the unit enters remote control mode, enabling menu operations and shooting operations.

### [Notes]

- Do not connect or disconnect the remote control unit when the unit is on.
- A remote control cable is not supplied with the RCP-1001/1501/3100/3501 Remote Control Panel.

---

## Releasing Remote Control Mode

---

Turn off the unit, and disconnect the remote control unit.

---

## Setting the Paint Function

---

Technical > Special Configuration > RM/RCP Paint Control (page 91) must be set to On in the full menu to enable the paint function.

## Main Functions Controllable using the RCP-1001/1501/3100/3501 or RM-B170/B750

### Table legend

The following indicate remote control support on the display.

Yes: Control supported

–: Control not supported

Item	Sub-item	Sub-item	Selection option	RCP-1001	RCP-1501/3501	RCP-3100	RM-B170	RM-B750
Shooting	FPS	Fixed/Variable Select	On/Off	–	Yes	–	Yes <sup>1)</sup>	Yes
		FPS Select	1FPS to 120FPS	–	Yes	–	Yes <sup>1)</sup>	Yes
	Shutter Select <sup>2)</sup>	Shutter ON/OFF	On/Off	–	Yes	Yes	Yes	Yes
		ECS ON/OFF	On/Off	–	Yes	Yes	Yes	Yes
		Shutter Speed	Values registered for Step. The following values can be displayed. 1/32 1/33 1/48 1/50 1/60 1/96 1/100 1/120 1/125 1/250 1/500 1/1000 1/2000 1/3000 1/4000 1/5000	–	Yes	Yes	Yes	Yes
		ECS Frequency	–	–	Yes	Yes	Yes	Yes
		ND	ND Position	1: (CLEAR) 2: (0.3 density) 3: (0.6 density) 4: (0.9 density) 5: (1.2 density) 6: (1.5 density) 7: (1.8 density) 8: (2.1 density) 9: (2.4 density)	Yes	Yes	Yes	Yes

Item	Sub-item	Sub-item	Selection option	RCP-1001	RCP-1501/3501	RCP-3100	RM-B170	RM-B750
	Gain <sup>2)</sup>	Gain(Step)	-6dB/-3dB/0dB/3dB/6dB/9dB/ 12dB/15dB/18dB	Yes	Yes	Yes <sup>1)</sup>	Yes	Yes
	White Balance <sup>2)</sup>	Color Temp	2000K to 15000K <sup>3)</sup>	-	Yes	Yes <sup>1)</sup>	-	Yes
		Color Temp Balance (Tint equivalent)	-99 to ±0 to +99 <sup>4)</sup>	-	Yes	Yes <sup>1)</sup>	-	Yes
		R Gain	-99 to ±0 to +99	Yes	Yes	-	Yes	Yes
		B Gain	-99 to ±0 to +99	Yes	Yes	-	Yes	Yes
		Auto White Balance	-	Yes	Yes	Yes	Yes	Yes
Project	Scene File <sup>2) 5)</sup>	-	-	-	Yes	Yes	-	Yes
	Standard File <sup>6)</sup>	-	-	Yes	Yes	-	-	Yes
Paint <sup>2)</sup>	Switch Status	Gamma	On/Off	-	Yes	Yes <sup>1)</sup>	Yes <sup>1)</sup>	Yes
		Black Gamma <sup>7)</sup>	On/Off	-	Yes	Yes <sup>1)</sup>	Yes <sup>1)</sup>	Yes
		Matrix	On/Off	-	Yes	Yes <sup>1)</sup>	-	Yes
		Knee <sup>7)</sup>	On/Off	-	Yes	Yes <sup>1)</sup>	Yes <sup>1)</sup>	Yes
		White Clip <sup>7)</sup>	On/Off	-	Yes	Yes <sup>1)</sup>	-	Yes
		Detail	On/Off	-	Yes	Yes <sup>1)</sup>	-	Yes
		Flare	On/Off	-	Yes	Yes	Yes <sup>1)</sup>	Yes
		Test Saw <sup>8)</sup>	On/Off	-	Yes	Yes	Yes <sup>1)</sup>	Yes
	Black	Master Black	-99 to ±0 to +99	Yes	Yes	Yes	Yes	Yes
		R Black	-99 to ±0 to +99	Yes	Yes	Yes	Yes	Yes
		B Black	-99 to ±0 to +99	Yes	Yes	Yes	Yes	Yes
	Flare	Setting	On/Off	-	Yes	Yes	Yes <sup>1)</sup>	Yes
		Master Flare	-99 to ±0 to +99	-	Yes	Yes	Yes <sup>1)</sup>	-
		R Flare	-99 to ±0 to +99	-	Yes	Yes	-	Yes
		G Flare	-99 to ±0 to +99	-	Yes	Yes	-	Yes
		B Flare	-99 to ±0 to +99	-	Yes	Yes	-	Yes
	Gamma	Setting	On/Off	-	Yes	Yes <sup>1)</sup>	Yes <sup>1)</sup>	Yes
		Gamma Category (display only) <sup>9)</sup>	User	-	Yes	-	-	Yes
		Gamma Select	User 1/User 2/User 3/User 4/User 5	-	Yes	-	-	Yes
	Black Gamma <sup>7)</sup>	Setting	On/Off	-	Yes	Yes <sup>1)</sup>	Yes <sup>1)</sup>	Yes
		Range	Low/L.Mid/H.Mid	-	Yes	-	-	Yes
Master Black Gamma		-99 to ±0 to +99	-	Yes	Yes <sup>1)</sup>	Yes <sup>1)</sup>	Yes	
Knee <sup>7) 10)</sup>	Setting	On/Off	Yes	Yes	Yes <sup>1)</sup>	Yes	Yes	
	Point	-99 to ±0 to +99	Yes	Yes	Yes <sup>1)</sup>	Yes	Yes	
	Slope	-99 to ±0 to +99	Yes	Yes	Yes <sup>1)</sup>	-	Yes	



Item	Sub-item	Sub-item	Selection option	RCP-1001	RCP-1501/3501	RCP-3100	RM-B170	RM-B750
Prev.	-	-	-	-	-	-	Yes	-
White Mode <sup>2)</sup>	Preset ON/OFF	-	On/Off	-	-	-	Yes	Yes
Iris	Iris Level	-	(Control range of target lens)	Yes	Yes	Yes	Yes	Yes
	Close	-	On/Off	Yes	Yes	Yes	-	Yes
Zoom <sup>11)</sup>	Remote	-	On/Off	-	Yes <sup>1)</sup>	Yes <sup>1)</sup>	Yes <sup>1)</sup>	-
	Speed	-	-	-	-	-	-	-
	Tele to Wide	-	-	-	Yes <sup>1)</sup>	Yes <sup>1)</sup>	Yes <sup>1)</sup>	-
	Zoom Value[%]	-	-	-	Yes <sup>1)</sup>	Yes <sup>1)</sup>	Yes <sup>1)</sup>	-
	Focal Length[mm]	-	-	-	Yes <sup>1)</sup>	Yes <sup>1)</sup>	Yes <sup>1)</sup>	-
Focus <sup>11)</sup>	Remote	-	On/Off	-	Yes <sup>1)</sup>	Yes <sup>1)</sup>	Yes <sup>1)</sup>	-
	Focus Position	-	-	-	Yes <sup>1)</sup>	Yes <sup>1)</sup>	Yes <sup>1)</sup>	-
	Focus Value[%]	-	-	-	Yes <sup>1)</sup>	Yes <sup>1)</sup>	Yes <sup>1)</sup>	-
	Focus Length[m]	-	-	-	Yes <sup>1)</sup>	Yes <sup>1)</sup>	Yes <sup>1)</sup>	-
Call	-	-	-	Yes	Yes	Yes	Yes	Yes

1) Controllable when assigned to operation block of controller.

2) Controllable only when Technical > Special Configuration > RM/RCP Paint Control (page 91) is set to On in the full menu.

3) Since Color Temp is clipped at 2000K and 15000K during R/B Gain operation, it may not be possible to display the correct Color Temp value for the R/B Gain value.

4) Since Color Temp Balance is clipped at ±99, it may not be possible to display the correct Color Temp Balance value for the R/B Gain value.

5) Scene files 1 to 5 can be selected or deselected only after they have been loaded into the unit.

6) Allows you to restore the settings of the unit to standard state from the controller without any scene files loaded.

7) Configurable only when Project > Basic Setting > Input Color Space (page 72) is set to HLG(Natural), HLG(Live), Rec.2020/User Gamma, or Rec.709/User Gamma in the full menu.

8) The test signal cannot be switched on/of during auto white balance execution.

9) May not be displayed depending on the controller model and version.

10) The normal Knee function of the unit controls the high-luminance knee equivalent of HDR Knee.

11) The zoom and focus drive instructions from a remote control unit are disabled when an E-mount lens is attached.

# Connecting External Monitors and Recording Devices

To display the recording/playback image on an external monitor, select the output signal and use an appropriate cable for the monitor to be connected.

The output signal from the unit can be recorded by connecting a recording device, such as a VTR.

The same status information and menus can be displayed on the external monitor as those on the viewfinder screen. Set the content to display, according to the output signal for the monitor, using the Monitoring menu (page 77).

## [Note]

When FPS is set to Variable, horizontal image shift may occur with 4K output only. This phenomenon may be noticeable for faster frame rates (FPS). However, this does not affect the recorded image, and the playback image is displayed correctly.

## SDI OUT Connector (BNC Type)

Set the output format using the Monitoring menu (page 77).

Use a commercially available 75-ohm coaxial cable for connection.

## [Note]

Check that the ground connection between the unit and external device is securely grounded before turning the power on. (We recommend turning on the unit and external device after connecting a 75-ohm coaxial cable.) When connecting an external device to the unit while the unit is turned on, connect to the unit after connecting a 75-ohm coaxial cable to the external device.

## To start synchronized recording on an external device

With SDI signal output selected, synchronized recording is possible by feeding a REC trigger signal to an external recording device connected to the SDI OUT connector. Enable

synchronized recording by setting Technical > System Configuration > SDI Rec Remote Trigger (page 87) in the menu to HD SDI Remote I/F or Parallel Rec.

## [Notes]

- If a connected external device does not support a REC trigger signal, the device cannot be operated.
- When outputting a monitor signal on SDI 3/4, the REC trigger signal is not output.
- When SDI 1/2 output is the following, the monitor signal is output on SDI 3/4.
  - 4K/QFHD 12G/6G output
  - 4K/QFHD Dual output

## MONITOR OUT Connector (BNC Type)

Outputs an HD SDI signal.

Set the output format using the Monitoring menu (page 77).

Use a commercially available 75-ohm coaxial cable for connection.

## [Note]

Audio and timecode are not superimposed on this output.

## HDMI OUT Connector (Type A Connector)

Set the output format using the Monitoring menu (page 77).

Use a commercially available HDMI cable for connection.

If the output format has the same resolution as the MONITOR OUT connector signal, the same video signal is output.

## 12V OUT Connector (12 V DC Output, LEMO 2-pin)

Supplies 12 V DC power to an accessory when the power switch is set to ON.

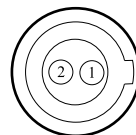

No.	Signal	I/O	Specification
1	UNREG GND	–	GND
2	UNREG +12 V OUT	OUT	+11 V to +17 V DC output <b>11 V to 17 V input</b> Output voltage: Same as the input voltage Maximum output current: 1.0 A <b>22 V to 32 V input</b> Output voltage: 16.8 V Maximum output current: 1.0 A

## 24V OUT Connector (24 V DC Output, Fischer 3-pin)

Supplies 24V DC power to an accessory when the power switch is set to ON. You can input a REC Trigger signal through the 24V OUT connector.

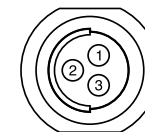

No.	Signal	Specification
1	GND	
2	24V-OUT	<b>11 V to 17 V input</b> Output voltage: 24 V Maximum output current: 1.0 A <b>22 V to 32 V input</b> Output voltage: Same as the input voltage Maximum output current: 2.0 A
3	REC TRIGGER IN	Open or +5 V DC: Normal GND: Active (REC)

## AUX connector (BNC Type)

Outputs the timecode signal or a clock signal for adjustment during manufacturing/servicing.

- TC OUT
- Factory Use

Use a commercially available 75-ohm coaxial cable for connection.



# External Synchronization

When shooting with multiple units, synchronized recording can be performed using a specific reference signal to synchronize the timecode among all the units.

## Synchronizing the Phase of the Video Signal (Genlock)

Genlock operation is enabled by supplying one of the following reference signals to the GENLOCK IN connector (page 12) of the unit.

- HDSDI 1.5G digital (Interlaced/PsF/Progressive)
- HD Y analog (Interlaced/Progressive)
- SD VBS analog

Set the genlock input signal using TC/Media > Genlock > Input Source (page 76) in the full menu.

You can also check the genlock status using TC/Media > Genlock > Reference Lock Type (page 76) in the full menu, the Home screen of the sub display (page 36), and the genlock status indicator (page 14).

Valid input reference signals vary depending on the project frame rate setting.

Project frame rate	Valid reference signal	
	Analog	Digital
23.98	1920×1080 47.95i (23.98PsF)	1920×1080 23.98PsF
	1920×1080 23.98P	1920×1080 23.98P
	1920×1080 24P	1920×1080 24P
24	1920×1080 48i (24PsF)	1920×1080 24PsF
	1920×1080 24P	1920×1080 24P
	1920×1080 24P	1920×1080 24P
25	1920×1080 50i	1920×1080 50i
	720×576 50i	1920×1080 25PsF
	1920×1080 25P	1920×1080 25P

Project frame rate	Valid reference signal	
	Analog	Digital
29.97	1920×1080 59.94i	1920×1080 59.94i
	720×486 59.94i	1920×1080 29.97PsF
	1920×1080 29.97P	1920×1080 29.97P
47.95	1920×1080 47.95i (23.98PsF)	1920×1080 23.98PsF
	1920×1080 47.95i	1920×1080 23.98PsF
50	1920×1080 50i	1920×1080 50i
	720×576 50i	1920×1080 50i
59.94	1920×1080 59.94i	1920×1080 59.94i
	720×486 59.94i	1920×1080 59.94i

You can check the genlock status using TC/Media > Genlock > Reference Lock Type (page 76) in the menu.

### [Notes]

- If the reference signal is unstable, genlock is not possible.
- The subcarrier is not synchronized.

## Synchronizing the Timecode with Another Device

Set the unit that supplies the timecode to a mode in which the timecode output keeps advancing (Free Run mode).

- 1 Set TC/Media > Timecode > Mode (page 76) in the menu to Preset F-Run (Ext-Lk).
- 2 Supply an HD or SD reference video signal to the GENLOCK IN connector (page 12) and a reference timecode synchronized with that signal to the TC IN (page 12) connector.

The built-in timecode generator of your unit locks to the reference timecode, and the message “Ext-Lk” is displayed on the Home screen of the sub display.

Once about ten seconds have elapsed after the timecode locks, the external lock state is maintained even if the external timecode source is disconnected.

### [Notes]

- Check that the reference timecode and the reference video signal are in a phase relationship that complies with the SMPTE timecode standards.
- When you finish the above procedure, the timecode is immediately synchronized with the external timecode, and the time data indication will show the value of the external timecode. However, wait for a few seconds until the timecode generator stabilizes before recording.
- If the frequency of the reference video signal and the frame frequency are not the same, lock cannot be acquired, and the unit will not operate properly. If this occurs, the timecode will not acquire successful lock with the external timecode.
- When the connection is removed, the timecode advance may shift one frame per hour with respect to the reference timecode.

## To release external lock

Change the TC/Media > Timecode > Mode (page 76) setting in the menu.

# Usage Precautions

Read this section in conjunction with the information provided in the supplied "Before Using This Unit" document.

## Use and Storage

### Do not subject the unit to severe shock

The internal mechanism may be damaged or the body warped.

### Do not cover the unit while operating

Putting a cloth, for example, over the unit can cause excessive internal heat build-up.

### After use

Always set the power switch to OFF.

### Before storing the unit for a long period

Remove the battery pack.

### Do not leave the unit with the lens facing the sun

Direct sunlight can enter through the lens, be focused in the unit, and cause fire.

## Shipping

- Remove the memory cards before transporting the unit.
- If sending the unit by truck, ship, air or other transportation service, pack it in the shipping carton of the unit.

## Care of the Unit

If the body of the unit is dirty, clean it with a soft, dry cloth. In extreme cases, use a cloth moistened in a little neutral detergent, then wipe dry.

Do not use organic solvents, such as alcohol or thinners, as these may cause discoloration or other damage to the finish of the unit.

Refrain from cleaning with high air pressure equipment, such as an air duster, as these may damage optical components.

### In the event of operating problems

If you should experience problems with the unit, contact your Sony dealer.

## Periodic Replacement of Fan and Battery

The fan and battery are consumable parts that will need periodic replacement.

When operating at room temperature, a normal replacement cycle will be about 5 years. However, this replacement cycle represents only a general guideline and does not imply that the life expectancy of these parts is guaranteed. For details on parts replacement, contact your dealer.

## Life Expectancy of the Electrolytic Capacitor

The life expectancy of the electrolytic capacitor is about 5 years under normal

operating temperatures and normal usage (8 hours per day; 25 days per month).

If usage exceeds the above normal usage frequency, the life expectancy may be reduced correspondingly.

## Note about the Battery Terminal

The battery terminal of this unit (the connector for battery packs and AC adaptors) is a consumable part.

Power may not be supplied to the unit properly if the pins of the battery terminal are bent or deformed by shock or vibrations, or if they become corroded due to prolonged outdoor use.

Periodic inspections are recommended to keep the unit working properly and to prolong its usable lifetime. Contact a Sony service or sales representative for more information about inspections.

## Use and Storage Locations

Store in a level, ventilated place.

Avoid using or storing the unit in the following places.

- In excessive heat or cold (operating temperature range: 0 °C to 40 °C (32 °F to 104 °F))  
Remember that in summer in warm climates the temperature inside a car with the windows closed can easily exceed 50 °C (122 °F).
- In damp or dusty locations
- Locations where the unit may be exposed to rain
- Locations subject to violent vibration
- Near strong magnetic fields

- Close to radio or TV transmitters producing strong electromagnetic fields.
- In direct sunlight or close to heaters for extended periods

## To prevent electromagnetic interference from portable communications devices

The use of portable telephones and other communications devices near this unit can result in malfunctions and interference with audio and video signals.

It is recommended that the portable communications devices near this unit be powered off.

## Note on laser beams

Laser beams may damage the CMOS image sensor. If you shoot a scene that includes a laser beam, be careful not to let the laser beam be directed into the lens of the unit. Specifically, high-power laser beams from medical devices or other devices may cause damage due to reflected light and scattered light.

## About the Screens

- Do not leave the screens facing direct sunlight, as this may damage the screens.
- Do not press/swipe the screens forcefully, or leave objects on the screens, as it may cause a malfunction, such as picture irregularity, etc.
- The screens may become warm in use. This is not a malfunction.

---

## LCD Panels

The LCD panel fitted to this unit is manufactured with high precision technology, giving a functioning pixel ratio of at least 99.99%. Thus a very small proportion of pixels may be “stuck”, either always off (black), always on (red, green, or blue), or flashing. In addition, over a long period of use, because of the physical characteristics of the liquid crystal display, such “stuck” pixels may appear spontaneously. These problems are not a malfunction. Note that any such problems have no effect on recorded data.

---

## OLED Panels

The OLED panel fitted to this unit is manufactured with high precision technology, giving a functioning pixel ratio of at least 99.99%. Thus a very small proportion of pixels may be “stuck”, either always off (black), always on, or flashing. In addition, over a long period of use, because of the physical characteristics of the organic light-emitting diode, such “stuck” pixels may appear spontaneously. These problems are not a malfunction. Note that any such problems have no effect on recorded data. Due to the characteristics of the material used in the OLED panel, permanent burn-in or reduction in brightness may occur. These problems are not a malfunction.

---

## On Condensation

If the unit is suddenly taken from a cold to a warm location, or if ambient temperature suddenly rises, moisture may form on the outer surface of the unit and/or inside of the unit. This is known as condensation. If condensation occurs, turn off the unit and wait until the condensation clears before operating the unit. Operating the unit while condensation is present may damage the unit.

---

## Phenomena Specific to CMOS Image Sensors

The following phenomena that may appear in images are specific to CMOS (Complementary Metal Oxide Semiconductor) image sensors. They do not indicate malfunctions.

### White flecks

Although the CMOS image sensors are produced with high-precision technologies, fine white flecks may be generated on the screen in rare cases, caused by cosmic rays, etc. This is related to the principle of image sensors and is not a malfunction. The white flecks especially tend to be seen in the following cases.

- When operating at high environmental temperatures

### Aliasing

When fine patterns, stripes, or lines are shot, they may appear jagged or flicker.

---

## Focal plane

Owing to the characteristics of the pickup elements (CMOS sensors) for reading video signals, subjects that quickly move across the screen may appear slightly skewed.

### Flashbanding

The luminance at the top and bottom of the screen may change when shooting a flashlight beam or a light source that quickly flashes.

### Flicker

If recording is made under lighting produced by discharge tubes, such as fluorescent, sodium, or mercury-vapor lamps, the screen may flicker, colors may vary, or horizontal stripes may appear distorted. The flicker can be reduced using the flicker reduction function of the unit (page 65).

---

## Notes on the Display

- Pictures on the viewfinder screen and outputs may be distorted by the following operations.
  - Changing the video format
  - Changing the FPS frame rate
  - When genlock is applied
- When you change the line of sight in the viewfinder, you may see primary colors red, green, and blue, but this is not a defect of the unit. These primary colors are not recorded on any recording media.

---

## Fragmentation

If pictures cannot be recorded/reproduced properly, try formatting the recording medium. While repeating picture recording/playback with a certain recording media for an extended period, files in the media may be fragmented, disabling proper recording/storage. In such a case, make a backup of clips in the media then perform formatting of the media using TC/Media > Format Media (page 76) in the menu.

## Output Voltages of the Unit

The total output power that can be supplied to peripheral devices from the unit varies depending on the input voltage to the unit and the state of the connected accessories. The maximum output capacity ratings of the following connectors that can supply power may not be achieved depending on the conditions.

**LENS connector: 1 A max.**

**12V OUT connector (2-pin): 1 A max.**

**24V OUT connector (3-pin):**

2 A max. (Input voltage: 22 V to 32 V)

1 A max. (Input voltage: 11 V to 17 V)

The power delivery rating available for accessories (DVF-EL200 and CBK-3610XS) and peripheral devices is limited depending on the input voltage to the unit.

Voltage of power supply to the unit: X [V]

Total power rating of peripheral devices:

Y [W]

Power consumption of the unit: Z [W]<sup>1)</sup>

① Power consumption of the DVF-EL200:

Approx. 2.5 W

② Power consumption of the CBK-3610XS:

Approx. 3.9 W

**Y [W] = X [V] × 9.0 [A]\* - (Z + ① + ②) [W]**

\* If X [V] × 9.0 [A] exceeds 220 [W], perform the calculation using 220 [W].

When supplying power to the above attached accessories and peripheral devices, make sure that the value Y given by the equation above does not become negative. It is recommended that the maximum power consumption value of the unit be used for the power consumption of the unit.<sup>1)</sup>

(Note that the equation does not apply if the calculated result Y exceeds the sum of the maximum allowable output power of each power output connector.)

1) MPC-3628:

Unit nominal power consumption: Approx. 76 W (8.6K 3:2, 24 FPS, X-OCN XT recording)

Unit maximum power consumption: Approx. 100 W (8.2K 17:9, 60 FPS, X-OCN ST recording, 40 °C (104 °F) environment, 32 V DC input)

MPC-3626:

Unit nominal power consumption: Approx. 73 W (6K 3:2, 24 FPS, X-OCN XT recording)

Unit maximum power consumption: Approx. 94 W (6K 3:2, 60 FPS, X-OCN ST recording, 40 °C (104 °F) environment, 32 V DC input)

## Notes on Security

- SONY WILL NOT BE LIABLE FOR DAMAGES OF ANY KIND RESULTING FROM A FAILURE TO IMPLEMENT PROPER SECURITY MEASURES ON TRANSMISSION DEVICES, UNAVOIDABLE DATA LEAKS RESULTING FROM TRANSMISSION SPECIFICATIONS, OR SECURITY PROBLEMS OF ANY KIND.
- Depending on the operating environment, unauthorized third parties on the network may be able to access the unit. When connecting the unit to the network, be sure to confirm that the network is protected securely.
- From a safety standpoint, when using the unit connected with the network, it is strongly recommended to access the Control window via a Web browser and change the access limitation settings from the factory preset values (page 87). Changing the password regularly is also recommended.
- Do not browse any other website in the Web browser while making settings or after making settings. Since the login status remains in the Web browser, close the Web browser when you complete the settings to prevent unauthorized third parties from using the unit or harmful programs from running.

# Recording Formats and Output Signals

## SDI OUT Connector Output Formats

The serial digital signal from an SDI OUT connector is output according to the Project category and Monitoring category settings in the menu.

For details about Project category settings combinations, see "Recording Format Settings" (page 59).

You can set the 3G SDI output format to Level A or Level B using Monitoring > Output Format > 3G SDI 1/2/3/4 Output (page 77) in the full menu.

Default values are shown underlined and in **bold** text.

Project			Monitoring > Output Format		Output format			
Project Frame Rate	Imager Mode	Recording Format	SDI 1/2	SDI 3/4	SDI 1	SDI 2	SDI 3	SDI 4
59.94/50	8.2K 17:9/	X-OCN XT	4096×2160P 12G	1920×1080P Level A <sup>1)</sup>	4096×2160P YPbPr 12G	4096×2160P YPbPr 12G	1920×1080P YPbPr 3G Level A	1920×1080P YPbPr 3G Level A
	6K 3:2/	X-OCN ST		<u>1920×1080i</u>			1920×1080i	1920×1080i
	6K 1.85:1/	X-OCN LT	4096×2160P Square Level B <sup>2)</sup>	4096×2160P Square Level B <sup>2)</sup>	4096×2160P YPbPr 3G Square Level B			
	6K 17:9/	ProRes 4444 4K			4096×2160P 2SI Level B <sup>2)</sup>	4096×2160P 2SI Level B <sup>2)</sup>	4096×2160P YPbPr 3G 2SI Level B	
	6K 2.39:1/	ProRes 422 HQ 4K	2048×1080P Level B <sup>2)</sup>	1920×1080P Level B <sup>2)</sup>			2048×1080P YPbPr 3G Level B	2048×1080P YPbPr 3G Level B
	5.8K 6:5/			<u>1920×1080i</u>	1920×1080i	1920×1080i		
	5.8K 17:9/		1920×1080P Level B <sup>2)</sup>	1920×1080P Level B <sup>2)</sup>	1920×1080P YPbPr 3G Level B	1920×1080P YPbPr 3G Level B	1920×1080P YPbPr 3G Level B	1920×1080P YPbPr 3G Level B
	4K 6:5/						<u>1920×1080i</u>	1920×1080i
	4K 4:3/		1920×1080P Level B <sup>2)</sup>	1920×1080P Level B <sup>2)</sup>	1920×1080P YPbPr 3G Level B	1920×1080P YPbPr 3G Level B	1920×1080P YPbPr 3G Level B	1920×1080P YPbPr 3G Level B
	4K 17:9/						<u>1920×1080i</u>	1920×1080i
4K 2.39:1			<u>1920×1080i</u>	1920×1080i	1920×1080i YPbPr 1.5G	1920×1080i YPbPr 1.5G	1920×1080i YPbPr 1.5G	1920×1080i YPbPr 1.5G

Project			Monitoring > Output Format		Output format					
Project Frame Rate	Imager Mode	Recording Format	SDI 1/2	SDI 3/4	SDI 1	SDI 2	SDI 3	SDI 4		
59.94/50	7.6K 16:9/ 5.7K 16:9/ 5.4K 16:9/ 3.8K 16:9	X-OCN XT X-OCN ST X-OCN LT ProRes 4444 QFHD ProRes 422 HQ QFHD	3840×2160P 12G	1920×1080P Level A <sup>1)</sup>	3840×2160P YPbPr 12G	3840×2160P YPbPr 12G	1920×1080P YPbPr 3G Level A	1920×1080P YPbPr 3G Level A		
				<a href="#">1920×1080i</a>			1920×1080i YPbPr 1.5G	1920×1080i YPbPr 1.5G		
			3840×2160P Square Level B <sup>2)</sup>	3840×2160P Square Level B <sup>2)</sup>	3840×2160P YPbPr 3G Square Level B					
			3840×2160P 2SI Level B <sup>2)</sup>	3840×2160P 2SI Level B <sup>2)</sup>	3840×2160P YPbPr 3G 2SI Level B					
			1920×1080P Level B <sup>2)</sup>	1920×1080P Level B <sup>2)</sup>	1920×1080P YPbPr 3G Level B	1920×1080P YPbPr 3G Level B	1920×1080P YPbPr 3G Level B	1920×1080P YPbPr 3G Level B	1920×1080P YPbPr 3G Level B	1920×1080P YPbPr 3G Level B
				<a href="#">1920×1080i</a>			1920×1080i YPbPr 1.5G	1920×1080i YPbPr 1.5G	1920×1080i YPbPr 1.5G	
			<a href="#">1920×1080i</a>	1920×1080i	1920×1080i YPbPr 1.5G	1920×1080i YPbPr 1.5G	1920×1080i YPbPr 1.5G	1920×1080i YPbPr 1.5G	1920×1080i YPbPr 1.5G	1920×1080i YPbPr 1.5G
			1920×1080i <sup>3)</sup>	1920×1080i <sup>3)</sup>	1920×1080i YPbPr 1.5G	1920×1080i YPbPr 1.5G	1920×1080i YPbPr 1.5G	1920×1080i YPbPr 1.5G	1920×1080i YPbPr 1.5G	1920×1080i YPbPr 1.5G
47.95	8.2K 17:9/ 6K 3:2/ 6K 1.85:1/ 6K 17:9/ 6K 2.39:1/ 5.8K 6:5/ 5.8K 17:9/ 4K 6:5/ 4K 4:3/ 4K 17:9/ 4K 2.39:1 3.8K 16:9	X-OCN XT X-OCN ST X-OCN LT	4096×2160P Square Level B <sup>2)</sup>	4096×2160P Square Level B <sup>2)</sup>	4096×2160P YPbPr 3G Square Level B					
			4096×2160P 2SI Level B <sup>2)</sup>	4096×2160P 2SI Level B <sup>2)</sup>	4096×2160P YPbPr 3G 2SI Level B					
			2048×1080P Level B <sup>2)</sup>	1920×1080P	2048×1080P YPbPr 3G Level B	2048×1080P YPbPr 3G Level B	1920×1080P YPbPr 1.5G	1920×1080P YPbPr 1.5G		
			<a href="#">1920×1080P</a>	1920×1080P	1920×1080P YPbPr 1.5G	1920×1080P YPbPr 1.5G	1920×1080P YPbPr 1.5G	1920×1080P YPbPr 1.5G		

Project			Monitoring > Output Format		Output format					
Project Frame Rate	Imager Mode	Recording Format	SDI 1/2	SDI 3/4	SDI 1	SDI 2	SDI 3	SDI 4		
29.97/25	8.6K 3:2/ 8.2K 17:9/ 6K 3:2/ 6K 1.85:1/ 6K 17:9/ 6K 2.39:1/ 5.8K 6:5/ 5.8K 17:9/ 4K 6:5/ 4K 4:3/ 4K 17:9/ 4K 2.39:1	X-OCN XT X-OCN ST X-OCN LT ProRes 4444 4K ProRes 422 HQ 4K	4096×2160P 6G	1920×1080P	4096×2160P YPbPr 6G 2SI	4096×2160P YPbPr 6G 2SI	1920×1080P YPbPr 1.5G	1920×1080P YPbPr 1.5G		
				<a href="#">1920×1080PsF</a>			1920×1080PsF YPbPr 1.5G	1920×1080PsF YPbPr 1.5G		
			4096×2160P Square	4096×2160P Square	4096×2160P YPbPr 1.5G Square					
			4096×2160P 2SI	1920×1080P	4096×2160P YPbPr 3G 2SI	1920×1080P YPbPr 1.5G	1920×1080P YPbPr 1.5G			
				<a href="#">1920×1080PsF</a>		1920×1080PsF YPbPr 1.5G	1920×1080PsF YPbPr 1.5G			
			2048×1080PsF	1920×1080P	2048×1080PsF YPbPr 1.5G	2048×1080PsF YPbPr 1.5G	1920×1080P YPbPr 1.5G	1920×1080P YPbPr 1.5G		
				<a href="#">1920×1080PsF</a>	1920×1080PsF YPbPr 1.5G	1920×1080PsF YPbPr 1.5G	1920×1080PsF YPbPr 1.5G	1920×1080PsF YPbPr 1.5G		
			1920×1080P	1920×1080P	1920×1080P YPbPr 1.5G	1920×1080P YPbPr 1.5G	1920×1080P YPbPr 1.5G	1920×1080P YPbPr 1.5G		
			<a href="#">1920×1080PsF</a>	1920×1080PsF	1920×1080PsF YPbPr 1.5G	1920×1080PsF YPbPr 1.5G	1920×1080PsF YPbPr 1.5G	1920×1080PsF YPbPr 1.5G		
			7.6K 16:9/ 5.7K 16:9/ 5.4K 16:9/ 3.8K 16:9	X-OCN XT X-OCN ST X-OCN LT ProRes 4444 QFHD ProRes 422 QFHD	3840×2160P 6G	1920×1080P	3840×2160P YPbPr 6G 2SI	3840×2160P YPbPr 6G 2SI	1920×1080P YPbPr 1.5G	1920×1080P YPbPr 1.5G
						<a href="#">1920×1080PsF</a>			1920×1080PsF YPbPr 1.5G	1920×1080PsF YPbPr 1.5G
					3840×2160P Square	3840×2160P Square	3840×2160P YPbPr 1.5G Square			
					3840×2160P 2SI	1920×1080P	3840×2160P YPbPr 3G 2SI	1920×1080P YPbPr 1.5G	1920×1080P YPbPr 1.5G	
						<a href="#">1920×1080PsF</a>		1920×1080PsF YPbPr 1.5G	1920×1080PsF YPbPr 1.5G	
1920×1080P	1920×1080P	1920×1080P YPbPr 1.5G			1920×1080P YPbPr 1.5G	1920×1080P YPbPr 1.5G	1920×1080P YPbPr 1.5G			
<a href="#">1920×1080PsF</a>	1920×1080PsF	1920×1080PsF YPbPr 1.5G	1920×1080PsF YPbPr 1.5G	1920×1080PsF YPbPr 1.5G	1920×1080PsF YPbPr 1.5G					

Project			Monitoring > Output Format		Output format				
Project	Frame Rate	Imager Mode	Recording Format	SDI 1/2	SDI 3/4	SDI 1	SDI 2	SDI 3	SDI 4
24	8.6K 3:2/	X-OCN XT X-OCN ST X-OCN LT ProRes 4444 4K ProRes 422 HQ 4K	X-OCN XT	4096×2160P 6G	1920×1080P	4096×2160P YPbPr 6G 2SI	4096×2160P YPbPr 6G 2SI	1920×1080P YPbPr 1.5G	1920×1080P YPbPr 1.5G
	8.2K 17:9/		X-OCN ST	4096×2160P Square	4096×2160P Square	4096×2160P YPbPr 1.5G Square			
	6K 3:2/		X-OCN LT	4096×2160P 2SI	1920×1080P	4096×2160P YPbPr 3G 2SI		1920×1080P YPbPr 1.5G	1920×1080P YPbPr 1.5G
	6K 1.85:1/		ProRes 4444 4K	2048×1080PsF	<a href="#">1920×1080P</a>	2048×1080PsF YPbPr 1.5G	2048×1080PsF YPbPr 1.5G	1920×1080P YPbPr 1.5G	1920×1080P YPbPr 1.5G
	6K 17:9/		ProRes 422 HQ 4K	1920×1080P	<a href="#">1920×1080P</a>	1920×1080P YPbPr 1.5G	1920×1080P YPbPr 1.5G	1920×1080P YPbPr 1.5G	1920×1080P YPbPr 1.5G
	6K 2.39:1/			<a href="#">1920×1080PsF</a>	1920×1080P	1920×1080PsF YPbPr 1.5G	1920×1080PsF YPbPr 1.5G	1920×1080P YPbPr 1.5G	1920×1080P YPbPr 1.5G
	5.8K 6:5/			3840×2160P 6G	1920×1080P	3840×2160P YPbPr 6G 2SI	3840×2160P YPbPr 6G 2SI	1920×1080P YPbPr 1.5G	1920×1080P YPbPr 1.5G
	5.8K 17:9/			3840×2160P Square	3840×2160P Square	3840×2160P YPbPr 1.5G Square			
	4K 6:5/			3840×2160P 2SI	1920×1080P	3840×2160P YPbPr 3G 2SI		1920×1080P YPbPr 1.5G	1920×1080P YPbPr 1.5G
	4K 4:3/			1920×1080P	<a href="#">1920×1080P</a>	1920×1080P YPbPr 1.5G	1920×1080P YPbPr 1.5G	1920×1080P YPbPr 1.5G	1920×1080P YPbPr 1.5G
	4K 17:9/		<a href="#">1920×1080PsF</a>	1920×1080P	1920×1080PsF YPbPr 1.5G	1920×1080PsF YPbPr 1.5G	1920×1080P YPbPr 1.5G	1920×1080P YPbPr 1.5G	
	4K 2.39:1		3840×2160P 6G	1920×1080P	3840×2160P YPbPr 6G 2SI	3840×2160P YPbPr 6G 2SI	1920×1080P YPbPr 1.5G	1920×1080P YPbPr 1.5G	
	7.6K 16:9/	X-OCN XT	3840×2160P Square	3840×2160P Square	3840×2160P YPbPr 1.5G Square				
	5.7K 16:9/	X-OCN ST	3840×2160P 2SI	1920×1080P	3840×2160P YPbPr 3G 2SI		1920×1080P YPbPr 1.5G	1920×1080P YPbPr 1.5G	
	5.4K 16:9/	X-OCN LT	1920×1080P	<a href="#">1920×1080P</a>	1920×1080P YPbPr 1.5G	1920×1080P YPbPr 1.5G	1920×1080P YPbPr 1.5G	1920×1080P YPbPr 1.5G	
3.8K 16:9	ProRes 4444 QFHD ProRes 422 QFHD	<a href="#">1920×1080PsF</a>	1920×1080P	1920×1080PsF YPbPr 1.5G	1920×1080PsF YPbPr 1.5G	1920×1080P YPbPr 1.5G	1920×1080P YPbPr 1.5G		



Project			Monitoring > Output Format		Output format								
Project	Frame Rate	Imager Mode	Recording Format	SDI 1/2	SDI 3/4	SDI 1	SDI 2	SDI 3	SDI 4				
23.98	8.6K 3:2/	X-OCN XT X-OCN ST X-OCN LT ProRes 4444 4K ProRes 422 HQ 4K	X-OCN XT X-OCN ST X-OCN LT ProRes 4444 4K ProRes 422 HQ 4K	4096×2160P 6G	<a href="#">1920×1080P</a>	4096×2160P	4096×2160P	1920×1080P	1920×1080P				
	YPbPr 6G 2SI					YPbPr 6G 2SI	YPbPr 1.5G	YPbPr 1.5G					
	6K 3:2/			ProRes 4444 4K ProRes 422 HQ 4K	ProRes 4444 4K ProRes 422 HQ 4K	4096×2160P Square	4096×2160P Square	4096×2160P YPbPr 1.5G Square					
	6K 1.85:1/					4096×2160P 2SI	<a href="#">1920×1080P</a>	4096×2160P YPbPr 3G 2SI		1920×1080P	1920×1080P		
	6K 17:9/							YPbPr 1.5G	YPbPr 1.5G	YPbPr 1.5G	YPbPr 1.5G		
	6K 2.39:1/					2048×1080PsF	<a href="#">1920×1080P</a>	1920×1080P	<a href="#">1920×1080P</a>	2048×1080PsF	2048×1080PsF	1920×1080P	1920×1080P
	5.8K 6:5/									YPbPr 1.5G	YPbPr 1.5G	YPbPr 1.5G	YPbPr 1.5G
	5.8K 17:9/					1920×1080P	<a href="#">1920×1080P</a>	1920×1080P	<a href="#">1920×1080P</a>	1920×1080P	1920×1080P	1920×1080P	1920×1080P
	4K 6:5/									YPbPr 1.5G	YPbPr 1.5G	YPbPr 1.5G	YPbPr 1.5G
	4K 4:3/					<a href="#">1920×1080PsF</a>	1920×1080P	1920×1080P	<a href="#">1920×1080P</a>	1920×1080PsF	1920×1080PsF	1920×1080P	1920×1080P
	4K 17:9/	YPbPr 1.5G	YPbPr 1.5G	YPbPr 1.5G	YPbPr 1.5G								
	4K 2.39:1	X-OCN XT X-OCN ST X-OCN LT ProRes 4444 QFHD ProRes 422 QFHD	X-OCN XT X-OCN ST X-OCN LT ProRes 4444 QFHD ProRes 422 QFHD	X-OCN XT X-OCN ST X-OCN LT ProRes 4444 QFHD ProRes 422 QFHD	3840×2160P 6G	<a href="#">1920×1080P</a>	3840×2160P	3840×2160P	1920×1080P	1920×1080P			
	7.6K 16:9/				3840×2160P Square	3840×2160P Square	3840×2160P YPbPr 1.5G Square						
	5.7K 16:9/						3840×2160P 2SI	1920×1080P	3840×2160P YPbPr 3G 2SI		1920×1080P	1920×1080P	
	5.4K 16:9/				YPbPr 1.5G	YPbPr 1.5G			YPbPr 1.5G	YPbPr 1.5G			
	3.8K 16:9				1920×1080P	<a href="#">1920×1080P</a>	1920×1080P	<a href="#">1920×1080P</a>	1920×1080P	1920×1080P	1920×1080P	1920×1080P	
	YPbPr 1.5G								YPbPr 1.5G	YPbPr 1.5G	YPbPr 1.5G		
	<a href="#">1920×1080PsF</a>	1920×1080P	1920×1080P	<a href="#">1920×1080PsF</a>	1920×1080PsF	1920×1080P	1920×1080P	1920×1080P					
				YPbPr 1.5G	YPbPr 1.5G	YPbPr 1.5G	YPbPr 1.5G	YPbPr 1.5G					

- 1) The Level A signal is output even when Monitoring > Output Format > 3G SDI 1/2/3/4 Output (page 77) is set to Level B in the full menu.
- 2) The menu setting changes to Level A and the Level A signal is output when Monitoring > Output Format > 3G SDI 1/2/3/4 Output is set to Level A in the full menu.
- 3) Set when Technical > Special Configuration > SD HDMI (page 91) is set to On in the full menu.

## MONITOR OUT Connector/HDMI OUT Connector Output Formats

The digital signal from the MONITOR OUT and HDMI OUT connectors is output according to the Project category and Monitoring category settings in the menu. For details about Project category settings combinations, see “Recording Format Settings” (page 59).

Default values are shown underlined and in **bold** text.

Project			Monitoring > Output Format				Output format		
Project Frame Rate	Imager Mode	Recording Format	SDI 1/2	SDI 3/4	Monitor	HDMI	Monitor Out	HDMI	
59.94/50	8.2K 17:9/	X-OCN XT	4096×2160P 12G	1920×1080P Level A <sup>1)</sup>	1920×1080P Level A	4096×2160P	1920×1080P	4096×2160P	
	6K 3:2/	X-OCN ST				<b>1920×1080P</b>	YPbPr 3G Level A	1920×1080P	
	6K 1.85:1/	X-OCN LT				4096×2160P	1920×1080P	4096×2160P	
	6K 17:9/	ProRes 4444 4K		<b>1920×1080i</b>	<b>1920×1080i</b>	<b>1920×1080i</b>	YPbPr 3G Level A	1920×1080i	
	6K 2.39:1/	ProRes 422 HQ 4K							
	5.8K 6:5/		4096×2160P	4096×2160P	1920×1080P Level A	1920×1080P	1920×1080P	1920×1080P	
	5.8K 17:9/		Square Level B <sup>2)</sup>	Square Level B <sup>2)</sup>			YPbPr 3G Level A	1920×1080P	
	4K 6:5/				<b>1920×1080i</b>	<b>1920×1080i</b>	1920×1080i	1920×1080i	
	4K 4:3/						YPbPr 1.5G		
	4K 17:9/				1920×1080P Level A	4096×2160P	1920×1080P	4096×2160P	
	4K 2.39:1					<b>1920×1080P</b>	YPbPr 3G Level A	1920×1080P	
				4096×2160P 2SI Level B <sup>2)</sup>	4096×2160P 2SI Level B <sup>2)</sup>		4096×2160P	1920×1080i	4096×2160P
						<b>1920×1080i</b>	<b>1920×1080i</b>	YPbPr 1.5G	1920×1080i
			2048×1080P Level B <sup>2)</sup>	1920×1080P Level B <sup>2)</sup>	1920×1080P Level A	1920×1080P	1920×1080P	1920×1080P	
				<b>1920×1080i</b>	1920×1080i	1920×1080i	1920×1080i	1920×1080i	
							YPbPr 1.5G		
			1920×1080P Level B <sup>2)</sup>	1920×1080P Level B <sup>2)</sup>	1920×1080P Level A	1920×1080P	1920×1080P	1920×1080P	
				<b>1920×1080i</b>	1920×1080i	1920×1080i	1920×1080i	1920×1080i	
							YPbPr 3G Level A		
			<b>1920×1080i</b>	1920×1080i	1920×1080i	1920×1080i	1920×1080i	1920×1080i	
							YPbPr 1.5G		

Project			Monitoring > Output Format				Output format								
Project	Frame Rate	Imager Mode	Recording Format	SDI 1/2	SDI 3/4	Monitor	HDMI	Monitor Out	HDMI						
59.94/50	7.6K 16:9/ 5.7K 16:9/ 5.4K 16:9/ 3.8K 16:9	X-OCN XT X-OCN ST X-OCN LT ProRes 4444 QFHD ProRes 422 HQ QFHD		3840×2160P 12G	1920×1080P Level A <sup>1)</sup>	1920×1080P Level A	3840×2160P	1920×1080P	3840×2160P						
							<a href="#">1920×1080P</a>	YPbPr 3G Level A	1920×1080P						
							3840×2160P	1920×1080P	3840×2160P						
							<a href="#">1920×1080i</a>	YPbPr 3G Level A	1920×1080i						
							3840×2160P	1920×1080P Level A	1920×1080P	1920×1080P					
							Square Level B <sup>2)</sup>	3840×2160P	1920×1080P	1920×1080i					
							<a href="#">1920×1080i</a>	YPbPr 1.5G	1920×1080i						
							3840×2160P	1920×1080P Level A	3840×2160P	3840×2160P					
							2SI Level B <sup>2)</sup>	3840×2160P	1920×1080P	1920×1080P					
							<a href="#">1920×1080i</a>	YPbPr 3G Level A	1920×1080i	3840×2160P					
							<a href="#">1920×1080i</a>	YPbPr 1.5G	1920×1080i	1920×1080i					
							47.95	8.2K 17:9/ 6K 3:2/ 6K 1.85:1/ 6K 17:9/ 6K 2.39:1/ 5.8K 6:5/ 5.8K 17:9/ 4K 6:5/ 4K 4:3/ 4K 17:9/ 4K 2.39:1/ 3.8K 16:9	X-OCN XT X-OCN ST X-OCN LT		4096×2160P Square Level B <sup>2)</sup>	4096×2160P Square Level B <sup>2)</sup>	1920×1080P	1920×1080P	1920×1080P YPbPr 1.5G
4096×2160P	4096×2160P	1920×1080P													
2SI Level B <sup>2)</sup>	2SI Level B <sup>2)</sup>	1920×1080P													
2048×1080P Level B <sup>2)</sup>	1920×1080P	1920×1080P													
<a href="#">1920×1080P</a>	1920×1080P	1920×1080P													
1920×1080P Level B <sup>2)</sup>	1920×1080P Level B <sup>2)</sup>	1920×1080P Level A	1920×1080P	1920×1080P	1920×1080P										
<a href="#">1920×1080i</a>	1920×1080i	1920×1080i	1920×1080i	1920×1080i	1920×1080i										
<a href="#">1920×1080i</a>	1920×1080i	1920×1080i	1920×1080i	1920×1080i	1920×1080i										
1920×1080P <sup>3)</sup>	1920×1080P <sup>3)</sup>	–	720×480P <sup>3)</sup>	–	720×480P <sup>3)4)</sup>										

Project			Monitoring > Output Format				Output format			
Project	Frame Rate	Imager Mode	Recording Format	SDI 1/2	SDI 3/4	Monitor	HDMI	Monitor Out	HDMI	
29.97/25	8.6K 3:2/ 8.2K 17:9/	X-OCN XT X-OCN ST	X-OCN LT	4096x2160P 6G	1920x1080P	1920x1080P	4096x2160P	1920x1080P	4096x2160P	
								<a href="#">1920x1080P</a>	YPbPr 1.5G	1920x1080P
	6K 3:2/ 6K 1.85:1/ 6K 17:9/	X-OCN LT ProRes 4444 4K ProRes 422 HQ 4K	X-OCN LT	4096x2160P Square	4096x2160P Square	1920x1080P	1920x1080P	4096x2160P	1920x1080P	4096x2160P
									<a href="#">1920x1080PsF</a>	YPbPr 1.5G
	6K 2.39:1/ 5.8K 6:5/ 5.8K 17:9/ 4K 6:5/ 4K 4:3/ 4K 17:9/ 4K 2.39:1	X-OCN XT X-OCN ST	X-OCN LT	4096x2160P 2SI	1920x1080P	1920x1080P	1920x1080P	4096x2160P	1920x1080P	4096x2160P
									<a href="#">1920x1080PsF</a>	YPbPr 1.5G
	2048x1080PsF	X-OCN XT X-OCN ST	X-OCN LT	1920x1080P	1920x1080P	1920x1080P	1920x1080P	1920x1080P	1920x1080P	1920x1080P
									<a href="#">1920x1080PsF</a>	YPbPr 1.5G
	1920x1080P	X-OCN XT X-OCN ST	X-OCN LT	1920x1080P	1920x1080P	1920x1080P	1920x1080P	1920x1080P	1920x1080P	1920x1080P
									<a href="#">1920x1080PsF</a>	YPbPr 1.5G
	7.6K 16:9/ 5.7K 16:9/ 5.4K 16:9/ 3.8K 16:9	X-OCN XT X-OCN ST	X-OCN LT	3840x2160P 6G	1920x1080P	1920x1080P	1920x1080P	3840x2160P	1920x1080P	3840x2160P
									<a href="#">1920x1080PsF</a>	YPbPr 1.5G
	3840x2160P Square	X-OCN XT X-OCN ST	X-OCN LT	3840x2160P Square	3840x2160P Square	1920x1080P	1920x1080P	3840x2160P	1920x1080P	3840x2160P
									<a href="#">1920x1080PsF</a>	YPbPr 1.5G
	3840x2160P 2SI	X-OCN XT X-OCN ST	X-OCN LT	1920x1080P	1920x1080P	1920x1080P	1920x1080P	3840x2160P	1920x1080P	3840x2160P
									<a href="#">1920x1080PsF</a>	YPbPr 1.5G
	1920x1080P	X-OCN XT X-OCN ST	X-OCN LT	1920x1080P	1920x1080P	1920x1080P	1920x1080P	1920x1080P	1920x1080P	1920x1080P
									<a href="#">1920x1080PsF</a>	YPbPr 1.5G

Project			Monitoring > Output Format				Output format			
Project	Frame Rate	Imager Mode	Recording Format	SDI 1/2	SDI 3/4	Monitor	HDMI	Monitor Out	HDMI	
24	8.6K 3:2/		X-OCN XT				4096×2160P			
	8.2K 17:9/		X-OCN ST	4096×2160P 6G	1920×1080P	<a href="#">1920×1080P</a>		1920×1080P YPbPr 1.5G	4096×2160P	
	6K 3:2/		X-OCN LT				<a href="#">1920×1080P</a>		1920×1080P	
	6K 1.85:1/		ProRes 4444 4K							
	6K 17:9/		ProRes 422 HQ 4K	4096×2160P Square	4096×2160P Square	<a href="#">1920×1080P</a>	1920×1080P	1920×1080P YPbPr 1.5G	1920×1080P	
	6K 2.39:1/									
	5.8K 6:5/			4096×2160P 2SI	1920×1080P	<a href="#">1920×1080P</a>	4096×2160P	1920×1080P	4096×2160P	
	5.8K 17:9/						<a href="#">1920×1080P</a>	1920×1080P YPbPr 1.5G	1920×1080P	
	4K 6:5/			2048×1080PsF	<a href="#">1920×1080P</a>	1920×1080P	1920×1080P	1920×1080P YPbPr 1.5G	1920×1080P	
	4K 4:3/									
	4K 17:9/			1920×1080P	<a href="#">1920×1080P</a>	1920×1080P	1920×1080P	1920×1080P YPbPr 1.5G	1920×1080P	
	4K 2.39:1									
					<a href="#">1920×1080PsF</a>	1920×1080P	1920×1080P	1920×1080P	1920×1080P YPbPr 1.5G	1920×1080P
	7.6K 16:9/		X-OCN XT					3840×2160P		3840×2160P
5.7K 16:9/		X-OCN ST	3840×2160P 6G	1920×1080P	1920×1080P		<a href="#">1920×1080P</a>	1920×1080P YPbPr 1.5G	1920×1080P	
5.4K 16:9/		X-OCN LT								
3.8K 16:9		ProRes 4444 QFHD	3840×2160P Square	3840×2160P Square	1920×1080P	1920×1080P	1920×1080P	1920×1080P YPbPr 1.5G	1920×1080P	
		ProRes 422 QFHD								
			3840×2160P 2SI	1920×1080P	1920×1080P		3840×2160P	1920×1080P	3840×2160P	
							<a href="#">1920×1080P</a>	1920×1080P YPbPr 1.5G	1920×1080P	
			1920×1080P	<a href="#">1920×1080P</a>	1920×1080P	1920×1080P	1920×1080P	1920×1080P YPbPr 1.5G	1920×1080P	
				<a href="#">1920×1080PsF</a>	1920×1080P	1920×1080P	1920×1080P	1920×1080P YPbPr 1.5G	1920×1080P	

Project			Monitoring > Output Format				Output format	
Project Frame Rate	Imager Mode	Recording Format	SDI 1/2	SDI 3/4	Monitor	HDMI	Monitor Out	HDMI
23.98	8.6K 3:2/	X-OCN XT	4096×2160P 6G	<a href="#">1920×1080P</a>	1920×1080P	4096×2160P	1920×1080P YPbPr 1.5G	4096×2160P
	8.2K 17:9/	X-OCN ST				<a href="#">1920×1080P</a>		
	6K 3:2/	X-OCN LT	4096×2160P Square	4096×2160P Square	1920×1080P	1920×1080P	1920×1080P YPbPr 1.5G	1920×1080P
	6K 1.85:1/	ProRes 4444 4K						
	6K 17:9/	ProRes 422 HQ 4K						
	6K 2.39:1/		4096×2160P 2SI	<a href="#">1920×1080P</a>	1920×1080P	4096×2160P	1920×1080P YPbPr 1.5G	4096×2160P
	5.8K 6:5/					<a href="#">1920×1080P</a>		1920×1080P
	5.8K 17:9/		2048×1080PsF	<a href="#">1920×1080P</a>	1920×1080P	1920×1080P	1920×1080P YPbPr 1.5G	1920×1080P
	4K 6:5/							
	4K 4:3/							
	4K 17:9/			<a href="#">1920×1080P</a>	1920×1080P	1920×1080P	1920×1080P YPbPr 1.5G	1920×1080P
	4K 2.39:1			<a href="#">1920×1080PsF</a>	1920×1080P	1920×1080P	1920×1080P YPbPr 1.5G	1920×1080P
	7.6K 16:9/	X-OCN XT	3840×2160P 6G	<a href="#">1920×1080P</a>	1920×1080P	3840×2160P	1920×1080P YPbPr 1.5G	3840×2160P
	5.7K 16:9/	X-OCN ST						<a href="#">1920×1080P</a>
5.4K 16:9/	X-OCN LT	3840×2160P Square	3840×2160P Square	1920×1080P	1920×1080P	1920×1080P YPbPr 1.5G	1920×1080P	
3.8K 16:9	ProRes 4444 QFHD							
	ProRes 422 QFHD							
		3840×2160P 2SI	1920×1080P	1920×1080P	3840×2160P	1920×1080P YPbPr 1.5G	3840×2160P	
					<a href="#">1920×1080P</a>		1920×1080P	
			<a href="#">1920×1080P</a>	1920×1080P	1920×1080P	1920×1080P YPbPr 1.5G	1920×1080P	
			<a href="#">1920×1080PsF</a>	1920×1080P	1920×1080P	1920×1080P YPbPr 1.5G	1920×1080P	

1) The Level A signal is output even when Monitoring > Output Format > 3G SDI 1/2/3/4 Output (page 77) is set to Level B in the full menu.

2) The menu setting changes to Level A and the Level A signal is output when Monitoring > Output Format > 3G SDI 1/2/3/4 Output is set to Level A in the full menu.

3) Set when Technical > Special Configuration > SD HDMI (page 91) is set to On in the full menu.

4) Configurable when Imager Mode or Zoom to Fit is set to 16:9 and Recording Format is set to X-OCN ST. The HDMI output is 720×576P when the project frame rate is set to 50.

# AXS Clip Recording/Playback Time

The following tables show the recording/playback time when using AXS-A1TS66 (Unit: minutes).

**[Note]**

The recording and playback times are for a continuous recording as a single clip. The actual times may be shorter, depending on the number of clips recorded. The recording/playback time may vary due to usage conditions and memory characteristics.

## X-OCN Recording/Playback Time

### MPC-3628

Recording Format	Project Frame Rate	8.6K 3:2	8.2K 17:9	7.6K 17:9	5.8K 6:5	5.8K 17:9	5.4K 16:9
X-OCN XT	23.98/24	23	32	32	41	65	65
	25	22	31	31	39	62	62
	29.97	18	25	25	33	52	52
	47.95	-	-	-	20	32	-
	50	-	-	-	-	31	31
	59.94	-	-	-	-	26	26
X-OCN ST	23.98/24	34	47	47	60	95	95
	25	32	45	45	57	91	91
	29.97	27	37	37	48	76	76
	47.95	-	23	-	30	47	-
	50	-	22	22	-	45	45
	59.94	-	18	18	-	38	38
X-OCN LT	23.98/24	58	80	80	102	160	160
	25	55	77	77	98	154	154
	29.97	46	64	64	81	128	128
	47.95	-	40	-	51	80	-
	50	-	38	38	-	77	77
	59.94	-	32	32	-	64	64

## MPC-3626

Recording Format	Project Frame Rate	6K 3:2	6K 1.85:1	6K 17:9	6K 2.39:1	5.7K 16:9	4K 6:5	4K 4:3	4K 17:9	4K 2.39:1	3.8K 16:9
X-OCN XT	23.98/24	47	58	59	75	59	81	93	129	161	129
	25	45	56	57	72	57	78	89	124	155	124
	29.97	38	46	47	60	47	65	74	103	129	103
	47.95	23	29	29	37	–	41	46	64	81	–
	50	22	28	28	36	28	39	44	62	77	62
	59.94	19	23	23	30	23	32	37	51	64	51
X-OCN ST	23.98/24	69	85	87	109	87	119	135	188	235	188
	25	66	81	83	105	83	114	130	180	225	180
	29.97	55	68	69	87	69	95	108	150	188	150
	47.95	34	42	43	54	–	59	68	94	118	–
	50	33	40	42	52	42	57	65	90	113	90
	59.94	27	34	35	43	35	47	54	75	94	75
X-OCN LT	23.98/24	117	144	147	185	147	201	229	316	395	316
	25	112	138	141	177	141	193	220	304	380	304
	29.97	94	115	118	148	118	161	183	254	317	254
	47.95	58	72	74	92	–	101	115	159	199	–
	50	56	69	71	89	71	97	110	153	191	153
	59.94	47	57	59	74	59	81	92	127	159	127

## ProRes Recording/Playback Time

Project Frame Rate	4K 4444	4K 422 HQ	QFHD 4444	QFHD 422 HQ
23.98/24	98	146	104	156
25	94	140	100	150
29.97	78	117	83	125
50	47	70	50	75
59.94	39	58	41	62



# Error/Warning Indications

If a warning, caution, or operating condition that requires confirmation occurs on the unit, a message is displayed on the sub display, the REC lamp starts flashing, and a warning sound is emitted.

The buzzer is output to the built-in speaker or to the headphones connected via the headphone connector.

When the unit is turned on, a message appears on the sub display screen prompting you to execute Auto Pixel Restoration if the auto adjustment for the image sensor (Auto Pixel Restoration) has not been performed for a certain period of time. In this case, follow the on-screen instructions to execute Auto Pixel Restoration (page 87).

## Error Display

The unit will stop operation when the following kind of display occurs.

Error display indication	Buzzer	REC lamp	Cause and Solution
E + Error code	Intermittent	High-speed flashing	The unit may be defective. Recording stops even if ●REC is displayed on the viewfinder/monitor screen. Turn off the power and check the connected equipment, cables, and media. If the error persists when the unit is turned on again, contact your Sony service representative. (If power cannot be turned off by setting the power switch to OFF, remove the battery pack or the DC IN source.)

## Warning Display

When one of the following messages occurs, use the following table to resolve the problem.

Warning display indication	Buzzer	REC lamp	Cause and Solution
Media Full <sup>1)</sup>	Continuous	High-speed flashing	Clips could not be recorded, copied, or split because there is no remaining capacity on the AXS memory card. Replace immediately.
Battery End <sup>1)</sup>	Continuous	High-speed flashing	The battery pack is dead. Recording is disabled. Stop operation and recharge the battery pack.

Warning display indication	Buzzer	REC lamp	Cause and Solution
Temperature High <sup>1)</sup>	Intermittent	Flashing	The internal temperature is high. Turn off the unit and allow it to cool down before operating it again.
Insufficient Voltage <sup>1)</sup>	Continuous	High-speed flashing	The DC IN voltage is too low. Recording is disabled. Connect another power source.

1) Message is not displayed on the monitor screen.

## About temperature warnings

The Temperature High warning may be displayed when operating within the guaranteed operating temperature of the unit, depending on the operating mode and usage environment. Recording does not immediately stop when these messages are displayed, but the suggestions given in the Cause and Solution column of the table should be implemented promptly.

## Caution and Operation Confirmation Display

The following caution and operation confirmation messages may appear on the monitor screen or sub display, and warning icons may be displayed and messages displayed in the Info category > Camera Condition in the menu. Follow the instructions provided to resolve the issue.

Display indication	Cause and Solution
Backup Battery End Please Change	The remaining capacity of the backup battery is insufficient. Replace the backup battery.
Cannot Use AXS(A)* Please Change	A memory card that has been partitioned or a memory card containing more clips that can be handled by the unit was inserted. The card cannot be used in the unit, and must be replaced.
Cannot Use AXS(A)* Unsupported File System	A card using a different file system or an unformatted card was inserted. The card cannot be used in the unit, and must be replaced or formatted using the unit.
Media Error AXS(A)* Needs to be Restored	An error occurred with the memory card. The card requires restoration. Restore the card.

Display indication	Cause and Solution
AXS(A)* Error Recording Stopped Playback Stopped	Recording or playback stopped because an error occurred on the memory card. If the problem persists, replace the memory card.
Input AES/EBU is Invalid Emphasis	AES/EBU signal with unsupported emphasis was input. The unit only supports signals with 50 $\mu$ s + 15 $\mu$ s emphasis.
Input AES/EBU is not Pro Use	A signal other than Professional Use was input to the AES/EBU input. The unit is compatible with Professional Use only.
Fan Stopped	The fan in the unit has stopped. Avoid use under high temperature conditions. Turn the unit off and contact a Sony service representative.
XXXX License Y days Remaining (XXXX: Type of license, Y: Number of days remaining)	There are 2 days remaining before the license for the software option will expire.
Lens I/F Error	A fault was detected in the lens I/F communication when an E-mount lens is attached. Check the connection to the E-mount lens.
Set the "Password" of "Authentication".	Technical > Authentication > Password (page 87) has not been configured yet. Configure the setting.

\* "AXS(A)" is displayed for the AXS memory card in slot A, and "AXS(B)" is displayed for the AXS memory card in slot B.

# Items Saved in Files

## Table legend

Yes: Saved

No: Not saved

–: Not saved (temporary setting)

## Shooting Menu

Item	Sub-item	File type	
		All	Scene
FPS	Fixed/Variable Select	Yes	No
	FPS Select	Yes	No
Shutter <sup>1)</sup>	Shutter Select	Yes	Yes
	Step/Cont. Select	Yes	Yes
	Add/Change Step	–	–
	Delete Step	–	–
Flicker Reduce	Mode	Yes	No
	Frequency	Yes	No
ND	ND Position	Yes	Yes
Exposure Index	EI Select	Yes	Yes
Gain	Gain Select	Yes	Yes
White Balance <sup>1)</sup>	Color Temp. Select	Yes	Yes
	Add/Change Step	–	–
	Delete Step	–	–
	Auto White Balance	–	–
Look	Category	Yes	No
	Preset Look Select	Yes	No
	User 3D LUT Select	Yes	No
	ART Select	Yes	No
	ART Information	–	–
	ASC CDL Process	Yes	No
	ASC CDL Select	Yes	No
	ASC CDL Information	–	–

Item	Sub-item	File type	
		All	Scene
Look File	Load User 3D LUT	–	–
	Reset User 3D LUT	–	–
	Reset All User 3D LUTs	–	–
	Load ART	–	–
	Reset ART	–	–
	Reset All ARTs	–	–
	Load ASC CDL	–	–
	Reset ASC CDL	–	–
	Reset All ASC CDLs	–	–
LUT Select	SDI 1/2	Yes	–
	SDI 3/4	Yes	No
	Monitor	Yes	No
	HDMI	–	–
	VF LUT	Yes	No
	ProRes	Yes	No
	SDR Gain	Yes	No

1) Selection options added or edited by a user are also saved.

## Project Menu

Item	Sub-item	File type	
		All	Scene
Basic Setting	Imager Mode	Yes	No
	Project Frame Rate	Yes	No
	Input Color Space	Yes	Yes
	Recording Format	Yes	No
	Base ISO	Yes	Yes
	Anamo. De-Squeeze	Yes	No
	Zoom to Fit	Yes	No
	Assignable Button	<1>	Yes
	<2>	Yes	No
	<3>	Yes	No
	<4>	Yes	No
	<VF A>	Yes	No
	<VF B>	Yes	No
	<VF C>	Yes	No
	<User 1>	Yes	No
	<User 2>	Yes	No
	<User 3>	Yes	No
	<User 4>	Yes	No
	<User 5>	Yes	No
Special Recording	Cache Rec Select	Yes	No
	Max Cache Rec Duration	Yes	No
All File(Cam Setup)	Load SD Card	-	-
	Save SD Card	-	-
	File ID	Yes	No
	Format SD Card	-	-
Scene File	Recall Internal Memory	-	-
	Store Internal Memory	-	-
	Load SD Card	-	-
	Save SD Card	-	-
	File ID	No	Yes
User Gamma	Current Settings	-	-
	Load SD Card	-	-
	Reset	-	-

## TC/Media Menu

Item	Sub-item	File type	
		All	Scene
Timecode	Mode	Yes	No
	Manual Setting	-	-
	Reset	-	-
	TC Format	Yes	No
	TC Source	-	-
	Time Data Display	Yes	No
	Genlock	Input Source	Yes
	Reference Lock Type	-	-
Clip Name Format	Camera ID <sup>1)</sup>	Yes	No
	Reel Number <sup>1)</sup>	Yes	No
	Camera Position <sup>1)</sup>	Yes	No
Format Media	AXS Slot A	-	-
	AXS Slot B	-	-
	SD Card	-	-

1) When you load an All file, the data saved in internal memory is not overwritten.

## Monitoring Menu

Item	Sub-item	File type	
		All	Scene
Output Format	SDI 1/2	Yes	No
	SDI 3/4	Yes	No
	Monitor	Yes	No
	HDMI	Yes	No
	3G SDI 1/2/3/4 Output	Yes	No
Output Display	Flip Image	Yes	No
	Audio/Video Delay	Yes	No
	Monitor Magnifier Mode	Yes	No
	Monitor Magnifier Ratio	Yes	No
VF Display	VF LUT	Yes	No
	Overlay	Yes	No
	Frame Line	Yes	No
	VF Magnifier Mode	Yes	No
	VF Magnifier Ratio	Yes	No
	Color	Yes	No
	SDR Gain	Yes	No
VF Function	Double Speed Scan	Yes	No
	Peaking Frequency	Yes	No
	Assign<VF A>	Yes	No
	Assign<VF B>	Yes	No
	Assign<VF C>	Yes	No
	Zebra	Yes	No
	Zebra Select	Yes	No
	Zebra1 Level	Yes	No
	Zebra1 Aperture Level	Yes	No
	Zebra2 Level	Yes	No
	Overlays/Frame Line	VF	Yes
SDI 1/2		Yes	No
SDI 3/4		Yes	No
Monitor		Yes	No
HDMI		-	-
Overlay A/B Setup		Yes	No
Frame Line A/B Setup		Yes	No

Item	Sub-item	File type		
		All	Scene	
Frame Line Setup	Color	Yes	No	
	Center Marker	Yes	No	
	Aspect Ratio	Yes	No	
	Aspect Ratio Type	Yes	No	
	Surround View Type	Yes	No	
	Mask Level	Yes	No	
	Safety Zone	Yes	No	
	Aspect Safety Zone	Yes	No	
	Frame Line on Playback	Yes	No	
	User Frame Line 1	Select	Yes	No
		Preset Aspect Ratio	Yes	No
		Scaling	Yes	No
		Preset Aspect Ratio Type	Yes	No
Aspect Ratio(Pixels)		-	-	
Width		Yes	No	
Height		Yes	No	
H Position		Yes	No	
V Position		Yes	No	
Variable Aspect Type		-	-	
User Frame Line 2	Select	Yes	No	
	Preset Aspect Ratio	Yes	No	
	Scaling	Yes	No	
	Preset Aspect Ratio Type	-	-	
	Aspect Ratio(Pixels)	-	-	
	Width	Yes	No	
	Height	Yes	No	
	H Position	Yes	No	
	V Position	Yes	No	
	Variable Aspect Type	-	-	

## Audio Menu

Item	Sub-item	File type	
		All	Scene
Audio Input	Internal Mic Select	Yes	No
	XLR Audio L Select	Yes	No
	XLR Audio R Select	Yes	No
	XLR Audio L Level	Yes	No
	XLR Audio R Level	Yes	No
	XLR Mic Reference	Yes	No
Audio Monitor	Monitor CH	Yes	No
	Monitor Level	Yes	No
Audio Configuration	Alarm Level	Yes	No
	Input Limiter Mode	Yes	No
	AGC Level	Yes	No
	AGC Mono/Stereo	Yes	No
	MIC Input Mono/Stereo	Yes	No
	Phantom Power +48V	Yes	No
	Monitor Output CH Pair	Yes	No
	Headphone Mono/ST	Yes	No

## Paint Menu

Item	Sub-item	File type	
		All	Scene
Black	Master Black	Yes	Yes
	R Black	Yes	Yes
	B Black	Yes	Yes
Flare	Setting	Yes	Yes
	Master Flare	Yes	Yes
	R Flare	Yes	Yes
	G Flare	Yes	Yes
	B Flare	Yes	Yes
Gamma	Setting	Yes	Yes
	Gamma Category	-	-
	Gamma Select	Yes	Yes
Black Gamma	Setting	Yes	Yes
	Range	Yes	Yes
	Master Black Gamma	Yes	Yes
Knee	Setting	Yes	Yes
	Point	Yes	Yes
	Slope	Yes	Yes
White Clip	Setting	Yes	Yes
	Level	Yes	Yes
Detail	Setting	Yes	Yes
	Level	Yes	Yes
	H/V Ratio	Yes	Yes
	Crispening	Yes	Yes
	Level Depend	Yes	Yes
	Level Depend Level	Yes	Yes
	Frequency	Yes	Yes
	Knee Aperture	Yes	Yes
	Knee Aperture Level	Yes	Yes
	Limit	Yes	Yes
	White Limit	Yes	Yes
	Black Limit	Yes	Yes

Item	Sub-item	File type	
		All	Scene
Matrix	Setting	Yes	Yes
	User Matrix	Yes	Yes
	User Matrix R-G	Yes	Yes
	User Matrix R-B	Yes	Yes
	User Matrix G-R	Yes	Yes
	User Matrix G-B	Yes	Yes
	User Matrix B-R	Yes	Yes
	User Matrix B-G	Yes	Yes
Multi Matrix	Setting	Yes	Yes
	Area Indication	No	No
	Reset	-	-
	Axis	No	No
	Hue	Yes	Yes
	Saturation	Yes	Yes

## Technical Menu

Item	Sub-item	File type	
		All	Scene
System Configuration	Fan Control	Yes	No
	Shutter Mode	Yes	Yes
	SDI Rec Remote Trigger	Yes	No
	Level Gauge Adjust	-	-
	Level Gauge Reset	-	-
Lens Configuration	PL-Mt Interface Position	Yes	No
	PL-Mt Voltage	Yes	No
	Focus Distance Format	Yes	No
	Lens 12pin	Yes	No
	E-Mount Shading Comp.	Yes	No
	E-Mt Chro. Aber. Comp.	Yes	No
Auto Pixel Restore	Auto Pixel Restoration	-	-
	Reset	-	-
Authentication	User Name	No	No
	Password	No	No
Network	Setting	Yes	No
	LAN	Yes	No
	Wireless	Yes <sup>1)</sup>	No
Alerts & Tally	Rec Light	Yes	No
	Rec Start/Stop Beep	Yes	No
	Media Near Full Alarm	Yes	No
Batt./Voltage Alarm	Near End:Info Battery	Yes	No
	End:Info Battery	Yes	No
	Near End:Sony Battery	Yes	No
	End:Sony Battery	Yes	No
	Near End:Other Battery	Yes	No
	End:Other Battery	Yes	No
	Detected Battery	-	-
	DC Low Voltage1	Yes	No
	DC Low Voltage2	Yes	No
	DC(24V) Low Voltage1	Yes	No
	DC(24V) Low Voltage2	Yes	No

Item	Sub-item	File type	
		All	Scene
Panel Control	Brightness level	Yes	No
	Lock Operator Side	Yes	No
	Lock Assistant Side	Yes	No
False Color	Level	Yes	No
	Red	Yes	No
	Red Upper Limit	Yes	No
	Red Lower Limit	Yes	No
	Yellow	Yes	No
	Yellow Upper Limit	Yes	No
	Yellow Lower Limit	Yes	No
	Orange	Yes	No
	Orange Upper Limit	Yes	No
	Orange Lower Limit	Yes	No
	Pink	Yes	No
	Pink Upper Limit	Yes	No
	Pink Lower Limit	Yes	No
	Light Pink	Yes	No
	Light Pink Upper Limit	Yes	No
	Light Pink Lower Limit	Yes	No
	Cyan	Yes	No
	Cyan Upper Limit	Yes	No
	Cyan Lower Limit	Yes	No
	Green	Yes	No
	Green Upper Limit	Yes	No
	Green Lower Limit	Yes	No
	Light Blue	Yes	No
	Light Blue Upper Limit	Yes	No
	Light Blue Lower Limit	Yes	No
Blue	Yes	No	
Blue Upper Limit	Yes	No	
Blue Lower Limit	Yes	No	
Purple	Yes	No	
Purple Upper Limit	Yes	No	
Purple Lower Limit	Yes	No	
Reset	-	-	

Item	Sub-item	File type	
		All	Scene
Test Signals	Color Bars	Yes	No
	Color Bar Type	Yes	No
	1kHz Tone on Color Bars	Yes	No
	Test Saw	Yes	No
	Test Saw Type	Yes	No
Special Configuration	RM/RCP Paint Control	Yes	No
	NR(4K 17:9/16:9)	Yes	Yes
	SD HDMI	Yes	No
	360° Shutter Setting	Yes	No

1) The following items are not saved.

- Scan Networks
- SSID
- Password
- WPS
- MAC Address
- Regenerate Password



## Maintenance Menu

Item	Sub-item	File type	
		All	Scene
Language	Select	Yes	No
Clock Set	Time Zone	Yes	No
	Date Mode	Yes	No
	Date	-	-
	Time	-	-
Hours Meter	Hours (System)	-	-
	Hours (Resettable)	-	-
	Reset	-	-
Reset to Default	Reset	-	-
Network Reset	Reset	-	-
License Options	Install: xxx	-	-
	Anamorphic	-	-
	Full-Frame	-	-
	Unique Device ID	-	-
Firmware	Version	-	-
	Firmware Update	-	-

### [Note]

When Technical > Special Configuration > RM/RCP Paint Control (page 91) is set to On in the full menu, the following remote control unit items (page 116) are also saved in an All file.

- Black
- Flare
- Gamma<sup>1)</sup>
- Black Gamma<sup>1)</sup>
- Gain

1) Except when set to S-Log3.

# Recording and Output Metadata List

## Table legend

Opt: Included if information is available (optional)

Yes: Defined

–: Not defined

Item	Notation example in RAW Viewer	RAW/X-OCN MXF	RAW/X-OCN XML	ProRes MXF	ProRes XML	HD-SDI
Creation Date	2021-10-29 11:04:05	Yes	Yes	Yes	Yes	–
Last Update	2021-10-30 11:04:05	–	Yes	Yes	Yes	–
UMID	060A2B3401010501010D4313000000070BF4 1D2F494EB7A16DD045A68CDF2E	Yes	Yes	Yes	Yes	–
Start	03:36:29:20	Yes	Yes	Yes	Yes	–
End	03:36:32:19	Yes	Yes	Yes	Yes	–
Duration	00:00:03:00	Yes	Yes	Yes	Yes	–
Poster Frame		–	–	–	–	–
Recording Mode		–	Yes	–	Yes	–
Drop Frame	NDF	Yes	Yes	Yes	Yes	–
Camera	VENICE/CineAltaV	Yes	Yes	Yes	Yes	–
Video Codec	X-OCN XT	Yes	Yes	Yes	Yes	–
Resolution	6048×4032	Yes	Yes	Yes	Yes	–
Aspect Ratio	3:2	Yes	Yes	Yes	Yes	–
Format FPS	23.98p	Yes	Yes	Yes	Yes	–
Capture FPS	23.98p	Yes	Yes	Yes	Yes	–
Pixel Aspect	1:1	–	Yes	–	–	–
Flip	normal	–	Yes	–	–	–
Number of Audio Channels	4	Yes	Yes	Yes	Yes	–
Audio Codec	LPCM	Yes	Yes	Yes	Yes	–
Audio Bit Depth	24	Yes	Yes	Yes	Yes	–
Audio Sampling Rate	48000	Yes	Yes	Yes	Yes	–
Auto Exposure Mode	ManualExposureMode	Yes	–	Yes	–	Yes
Exposure Index	500	Yes	Yes	Yes	Yes	Yes
Auto Focus Sensing Area Setting	ManualFocusMode	Opt	–	Opt	–	Opt
ND Filter Wheel	1/4	Yes	Yes	Yes	Yes	Yes
Image Sensor Dimension Effective Width	35925um	Yes	–	Yes	–	Yes
Image Sensor Dimension Effective Height	23950um	Yes	–	Yes	–	Yes
Image Sensor Readout Mode	ProgressiveFrame	Yes	Yes	Yes	Yes	Yes
Shutter Speed Angle	172.50deg	Yes	Yes	Yes	Yes	Yes
Shutter Speed Time	1/50sec	Yes	–	Yes	–	Yes
Camera Master Gain Adjustment	0.00dB	Yes	–	Yes	–	Yes
ISO Sensitivity	500	Yes	Yes	Yes	Yes	Yes
Electrical Extender Magnification	100%	Yes	–	Yes	–	Yes

Item	Notation example in RAW Viewer	RAW/X-OCN MXF	RAW/X-OCN XML	ProRes MXF	ProRes XML	HD-SDI
Auto White Balance Mode	PresetWhiteBalanceSetup	Yes	–	Yes	–	Yes
White Balance	5500	Yes	Yes	Yes	Yes	Yes
Tint Correction	0.00000	Yes	–	Yes	Yes	Yes
Camera Master Black Level	3.0%	–	–	Yes	–	Yes
Capture Gamma Equation	scene-linear	Yes	Yes	Yes	Yes	Yes
Gamma for CDL	rec709	Yes	Yes	Yes	Yes	Yes
Color Primaries (Capture Color Primaries)		–	–	Yes	Yes	Yes
Camera Attributes	MPC-36289999999Version5.00	Yes	Yes	Yes	Yes	Yes
Effective Marker Aspect Ratio	6048:3202	Yes	Yes	Yes	Yes	Yes
User Frame Line 1	1920×1080+0+0	Yes	–	Yes	–	Yes
User Frame Line 2	1920×1080+0+0	Yes	–	Yes	–	Yes
Active Area Aspect Ratio	6048:4032	Yes	Yes	Yes	Yes	Yes
Pixel Aspect Ratio	1:1	Yes	Yes	Yes	Yes	Yes
Image Orientation	normal	Yes	–	Yes	Yes	Yes
Raw Black Code	512	Yes	Yes	–	–	–
Raw Gray Code	1504	Yes	Yes	–	–	–
Raw White Code	5472	Yes	Yes	–	–	–
Gamma for Look	s-log3-cine	Yes	Yes	Yes	Yes	Yes
Color for Look	s-gamut3-cine	Yes	Yes	Yes	Yes	Yes
Pre-CDL Transform	LUT:SL3SG3Ctos709.cube	Yes	Yes	Yes	Yes	Yes
Post-CDL Transform	none	Yes	Yes	Yes	Yes	Yes
Look Process Baked	false	Yes	Yes	Yes	Yes	Yes
Monitoring Characteristics	rec709	Yes	Yes	Yes	Yes	Yes
Monitoring Base Curve	rec709	Yes	Yes	Yes	Yes	Yes
Monitoring Color Primaries	rec709	Yes	Yes	Yes	Yes	Yes
Monitoring Coding Equations	rec709	Yes	Yes	Yes	Yes	Yes
Monitoring Descriptions	LUT:SL3SG3Ctos709.cube	Yes	Yes	Yes	Yes	Yes
Camera Tilt Angle	2.70000	Yes	–	Yes	–	Yes
Camera Roll Angle	1.30000	Yes	–	Yes	–	Yes
Focus Distance	2296mm	Opt	–	Opt	–	Opt
Aperture Value	3.14	Opt	–	Opt	–	Opt
Aperture Ring T Stop Position	2.8 + 3/10	Opt	–	Opt	–	Opt
Current Focal Length	0mm	Opt	–	Opt	–	Opt
Hyperfocal Distance	219224mm	Opt	–	Opt	–	Opt
Near Focus Distance	2273mm	Opt	–	Opt	–	Opt
Far Focus Distance	2319mm	Opt	–	Opt	–	Opt
Horizontal Field of View	27.9deg	Opt	–	Opt	–	Opt

Item	Notation example in RAW Viewer	RAW/X-OCN MXF	RAW/X-OCN XML	ProRes MXF	ProRes XML	HD-SDI
Entrance Pupil Position	+51mm	Opt	-	Opt	-	Opt
Normalised Zoom Value	0.000	Opt	-	Opt	-	Opt
Lens Serial Number	xxxxxxx	Opt	-	Opt	-	Opt
Iris F-Number	2.87	Opt	-	Opt	-	Opt
Iris T-Number	3.1	Opt	-	Opt	-	Opt
Iris Ring Position		Opt	-	Opt	-	Opt
Focus Position from Image Plane	2.296m	Opt	-	Opt	-	Opt
Focus Ring Position		Opt	-	Opt	-	Opt
Macro Setting	OFF	Opt	-	Opt	-	Opt
Lens Zoom 35mm Still Camera Equivalent	85mm	Opt	-	Opt	-	Opt
Lens Zoom Actual Focal Length	85mm	Opt	-	Opt	-	Opt
Zoom Ring Position		Opt	-	Opt	-	Opt
Anamorphic Lens Squeeze Ratio		Opt	-	Opt	-	Opt
Optical Extender Magnification	100%	Opt	-	Opt	-	Opt
Lens Attributes	xxxxxxx	Opt	Opt	Opt	Opt	Opt
Cooke /i technology		Opt	-	Opt	-	Opt
Cooke /i2 technology		Opt	-	Opt	-	Opt
Cooke /i3 technology		Opt	-	Opt	-	Opt
Zeiss eXtended metadata		Opt	-	Opt	-	Opt
Description		-	-	-	-	-
Circle		-	-	-	-	-
Project		-	-	-	-	-
Director Name		-	-	-	-	-
Director of Photography Name		-	-	-	-	-
Production		-	-	-	-	-
Camera Index		-	Yes	-	Yes	-
Reel		-	Yes	-	Yes	-
Scene		-	-	-	-	-
Cut		-	-	-	-	-
Take		-	-	-	-	-
Shot		-	Yes	-	Yes	-
Mark In		-	-	-	-	-
Mark Out		-	-	-	-	-

# Licenses

---

## On Accessing Software to which the GPL/LGPL Applies

---

This product uses software to which the GPL/LGPL applies. This informs you that you have a right to have access to, modify, and redistribute source code for these software programs under the conditions of the GPL/LGPL.

The source code is provided on the internet. Use the following URL and follow the download instructions.

<http://www.sony.net/Products/Linux/common/search.html>

We would prefer that you do not contact us about the contents of the source code.

For the content of these licenses, connect the unit to a network and view the OSS Information screen (page 103) on the web remote control screen.

---

## Open Source Software Licenses

---

On the basis of license contracts between Sony and the software copyright holders, this product uses open software.

To meet the requirements of the software copyright holders, Sony is obligated to inform you of the content of these licenses.

For the content of these licenses, connect the unit to a network and view the OSS Information screen (page 103) on the web remote control screen.

# Specifications

## General Specifications

Mass	MPC-3628: Approx. 4.3 kg (9 lb 7.7 oz) MPC-3626: Approx. 4.2 kg (9 lb 4.2 oz) (excluding handle, VF attachment)
Dimensions	See page 152.
Power requirements	12 V DC (11 V to 17 V) 24 V DC (22 V to 32 V)
Power consumption	MPC-3628: Unit nominal power consumption: Approx. 76 W (8.6K 3:2, 24 FPS, X-OCN XT recording, excluding viewfinder and peripheral devices) Unit maximum power consumption: Approx. 100 W (8.2K 17:9, 60 FPS, X-OCN ST recording, 40 °C (104 °F) environment, 32 V DC input, excluding viewfinder and peripheral devices) Total maximum power consumption: Approx. 220 W (22 V to 32 V DC input, including viewfinder and peripheral devices) MPC-3626: Unit nominal power consumption: Approx. 73 W (6K 3:2, 24 FPS, X-OCN XT recording, excluding viewfinder and peripheral devices) Unit maximum power consumption: Approx. 94 W (6K 3:2, 60 FPS, X-OCN ST recording, 40 °C (104 °F) environment, 32 V DC input, excluding viewfinder and peripheral devices)

Total maximum power consumption: Approx. 220 W (22 V to 32 V DC input, including viewfinder and peripheral devices)
Operating temperature 0 °C to 40 °C (32 °F to 104 °F)
Storage temperature -20 °C to +60 °C (-4 °F to +140 °F)
Continuous operating time Approx. 35 minutes (when using BP-GL95B)
Recording format (video)
X-OCN XT
X-OCN ST
X-OCN LT
ProRes 4444 4K
ProRes 4444 QFHD
ProRes 422 HQ 4K
ProRes 422 HQ QFHD
Recording format (audio)
LPCM 8CH (2CH recording/playback), 24-bit, 48 kHz
Recording project frame rate
X-OCN XT/ST/LT (MPC-3628):
8.6K 3:2 29.97P/25P/24P/23.98P
8.2K 17:9/5.8K 17:9 59.94P/50P/47.95P/29.97P/25P/ 24P/23.98P
7.6K 16:9/5.4K 16:9 59.94P/50P/29.97P/25P/24P/ 23.98P
5.8K 6:5 47.95P/29.97P/25P/24P/23.98P
X-OCN XT/ST/LT (MPC-3626):
6K 3:2/6K 1.85:1/6K 17:9/6K 2.39:1/4K 6:5/4K 4:3/4K 17:9/4K 2.39:1 59.94P/50P/47.95P/29.97P/25P/ 24P/23.98P

5.7K 16:9/3.8K 16:9 59.94P/50P/29.97P/25P/24P/ 23.98P
4K 4:3 Surround/4K 17:9 Surround/3.8K 16:9 Surround 29.97P/25P/24P/23.98P
ProRes 4444
4K: 4096×2160 59.94P/50P/29.97P/25P/24P/ 23.98P
QFHD: 3840×2160 59.94P/50P/29.97P/25P/24P/ 23.98P
ProRes 422 HQ
4K: 4096×2160 59.94P/50P/29.97P/25P/24P/ 23.98P
QFHD: 3840×2160 59.94P/50P/29.97P/25P/24P/ 23.98P
Recording/playback time See page 135.

## Camera

Imaging device	35 mm full size, single-chip CMOS image sensor
Number of pixels	MPC-3628: 50.0 M (total) MPC-3626: 24.8 M (total)

## Built-in filters

		ND filter A		
		Clear	0.3 (1/2)	0.6 (1/4)
ND filter B	Clear	Clear	0.3 (1/2)	0.6 (1/4)
		0.9 (1/8)	0.9 (1/8)	1.2 (1/16)
		1.8 (1/64)	1.8 (1/64)	2.1 (1/128)
				2.4 (1/256)

## ISO sensitivity

MPC-3628:
ISO 800
ISO 3200
MPC-3626:
ISO 500
ISO 2500

## Lens mount

PL-mount (with lens mount adaptor)
E-mount (without lens mount adaptor)

## Flange focal length

PL-mount: 52 mm
E-mount: 18 mm

Latitude	MPC-3628: 16 stops MPC-3626: 15+ stops
----------	---

## Input/Output

### Audio input

CH-1/CH-2: XLR-type 5-pin (female) (1), LINE / AES/EBU / MIC / MIC+48V selectable
---

DC input	XLR-type 4-pin (male) (1), 11 V to 17 V or 22 V to 32 V DC
----------	---

**DC output (12 V)**

- LEMO 2-pin (1),
  - 11 V to 17 V DC (Output voltage: Same as input voltage, Maximum output current: 1.0 A),
  - 22 V to 32 V DC (Output voltage: 16.8 V, Maximum output current: 1.0 A), Using battery adaptor

**[Note]**

Connect to the 12V OUT connector only devices with current consumption of 1.0 A or lower.

**DC output (24 V)**

- Fischer 3-pin (2),
  - 11 V to 17 V DC (Output voltage: 24 V, Maximum output current: 1.0 A),
  - 22 V to 32 V DC (Output voltage: Same as input voltage, Maximum output current: 2.0 A)

**[Note]**

Connect to the 24V OUT connector only devices with current consumption of 1.0 A or lower when the input voltage is 11 V to 17 V, or 2.0 A or lower when the input voltage is 22 V to 32 V.

**SDI output BNC type (4)**

- 3G-SDI: SMPTE ST424/425
  - Level B-DL/DS
- HD SDI: SMPTE ST292 compliant

**AUX BNC type (1)****Viewfinder output**

- LEMO 26-pin (1)

**Network RJ45 type (1)****Remote control**

- 8-pin (1)

**MONITOR output**

- BNC type (1)
- HD SDI: SMPTE ST292 compliant

**Timecode input**

- TC IN: BNC type (1)

**GENLOCK input**

- BNC type (1)

**HDMI output**

- Type A (1)

**External device connector**

- USB host: Type A (1)

**Headphones output**

- Stereo mini jack (1)

**Speaker output**

- Monaural

---

**Media Slots**

---

- |      |                |
|------|----------------|
| Type | AXS-A card (2) |
|      | SD card (1)    |

---

**Supplied Accessories**

---

**VF attachment (1)****Handle (1)****VF cable (1) (A-2203-745-A)****Shim (circular) (1) (4-730-328-11)****Shim (1/3 arc) (15) (4-730-328-21)****E-mount lens cap (1)****PL-mount lens cap (1)****Cover for 6K imager block (1) (A-5040-737-A)**  
(MPC-3628 only)**Before Using This Unit (1)**

---

**Related Accessories**

---

**0.7-inch type viewfinder**

- DVF-EL200, DVF-L700

**Camera Extension System**

- CBK-3610XS

**Wireless LAN Adaptor**

- CBK-WA02

**Remote Control Unit**

- RM-B170/B750
- RCP-1000/1500/1530/3500
- RCP-1001/1501/3100/3501

**Card Reader**

- AXS-AR3

**Shoulder Adaptor (attaches to VCT-14 using V shoe)**

- VCT-FSA5

**E-mount lens**

- SELP28135G, SEL1224GM, SEL1635GM, SEL2470GM, SEL70200GM, SEL100400GM, SEL24F14GM, SEL35F14GM, SEL50F12GM, SEL85F14GM, SEL100F28GM

**Battery Pack**

- BP-GL95B

**Microphone**

- ECM-680S, ECM-678\*, ECM-674\*
- \* EC-0.5X3F5M 3-pin XLR to 5-pin XLR adaptor cable required

**Dual Battery Adaptor**

- BKW-L200 (connection via battery connection adaptor)

**SDI/HDMI Monitor**

- BVM series, PVM series, LMD series

Design and specifications are subject to change without notice.

# Dimensions

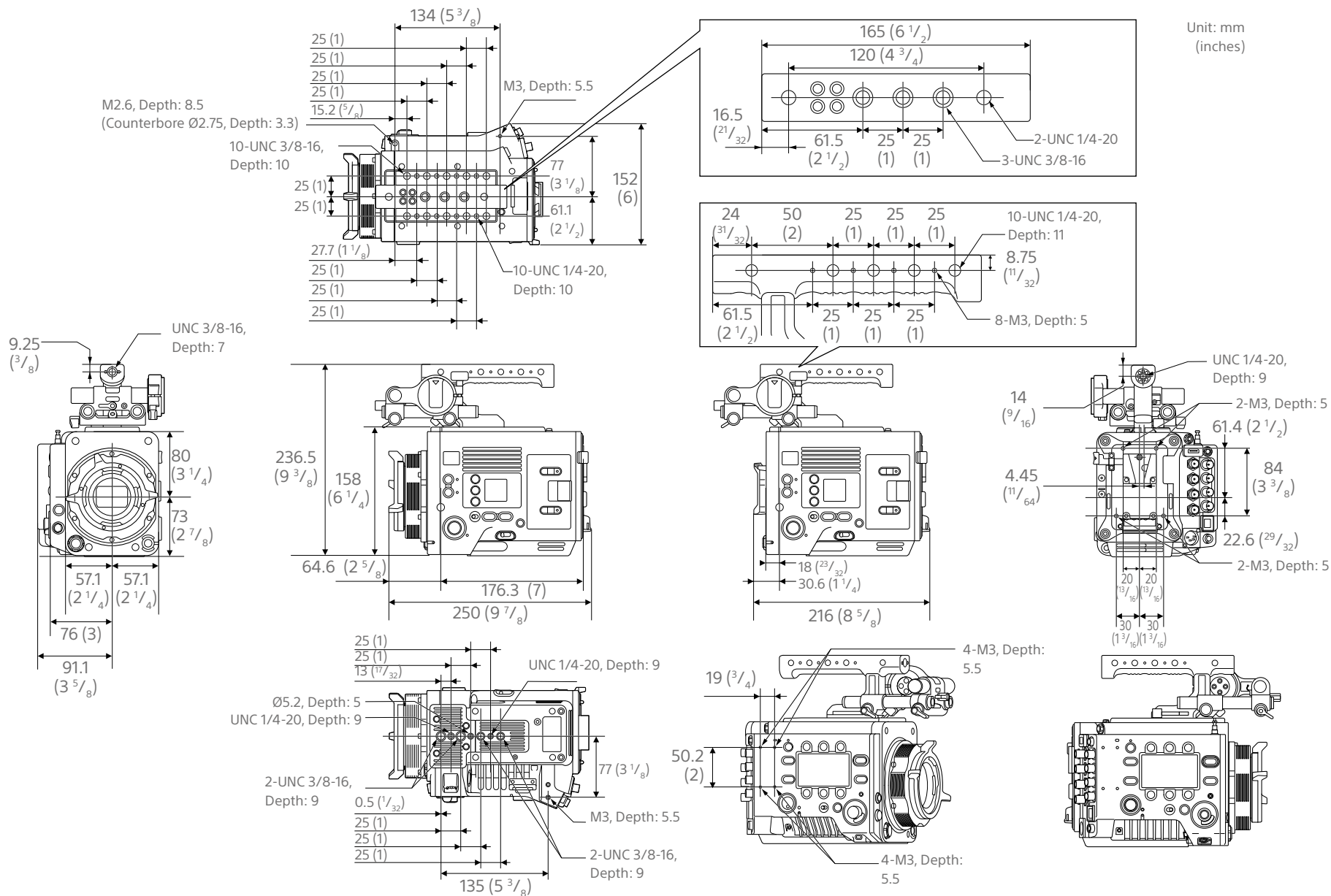



---

## Trademarks

---

- The terms HDMI and HDMI High-Definition Multimedia Interface, and the HDMI Logo are trademarks or registered trademarks of HDMI Licensing Administrator, Inc. in the United States and other countries.
- All system names and product names are registered trademarks or trademarks of their respective owners. Trademarked items are not indicated by ® or ™ symbols in this document.